

# Partial Insert Verabar®

*Flow Measurement  
Solutions for Large Pipes*



# VERIS



**Armstrong®**

## The Verabar Partial Insert Flow Sensor

Used in hundreds of applications as the cost effective solution for pipe sizes above 20" and designed specifically for high velocity cooling water applications, large diameter gas applications and applications where opposite support hardware is impossible or impractical such as large vertical stacks and buried water lines. The partial insert is designed to extend one-third the way into the pipe and sense half of the velocity profile (Table 1)—especially useful when a hot tap is required.

Table 1	Full Insert	Partial Insert	Length Reduction
Inserted Length	65" (5.4') 1651mm	36" (3') 914mm	29" (2.4') 737mm
Retracted Length	115" (9.6') 2921mm	60" (5') 1524mm	55" (4.6') 1397mm

## Partial Insert Reduces Sensor Installed Cost by 50%

Table 1 illustrates the reduction in overall length of a partial insert hot tap in a 36" cooling water line. The partial insert reduces the sensor's extension above the pipe by 2.4 ft (737mm) in the inserted position and 4.6 ft (1397mm) in the retracted position. The reduction in length can reduce the cost of the sensor up to 40%. It also greatly reduces the installation and operating costs.

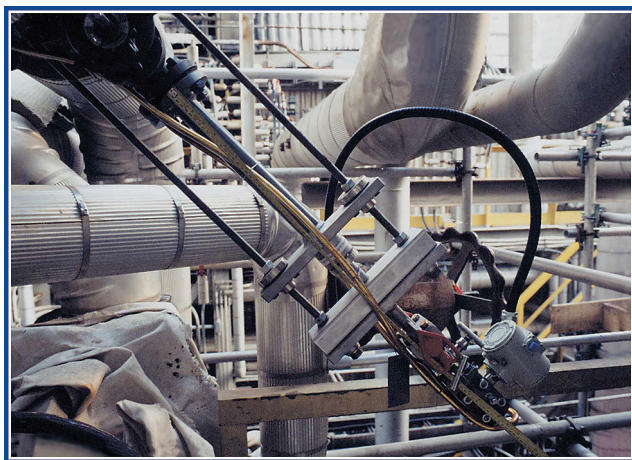

## Insert/Retract without Reducing Flow Rate

A structural calculation is made to verify the insertion length at maximum flow. Unlike full insert hot taps that may require a reduction in flow rate, a partial insert hot tap can be inserted and retracted any time.

## Partial Insert vs. Full Insert Flow Sensors

The partial insert flow sensor is designed to extend one-third the way into the pipe reducing production and installation costs.

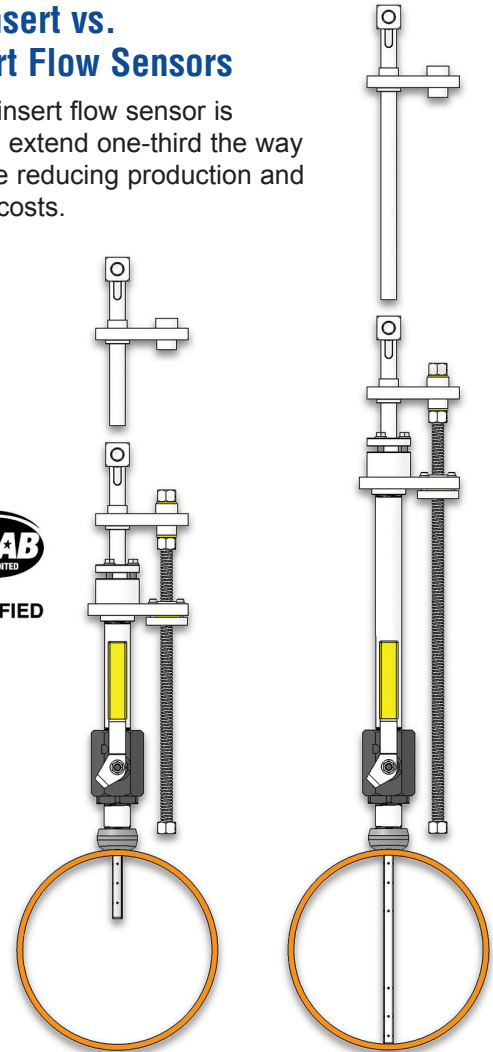

## Velocity Flow Profile

With sufficient straight run, the velocity profile is fully developed and the partial insert is as accurate as a full insertion sensor.

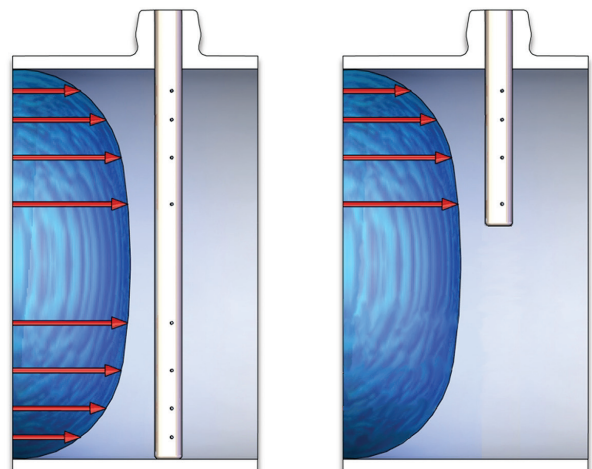

# Partial Insert Verabar® ...For Large Pipe Sizes

## Accuracy

If the velocity profile is fully developed, the partial insert is nearly as accurate as a full insertion sensor ( $\pm 1\%$  to  $\pm 2\%$ ). If there is insufficient straight run, consult the factory for a specific accuracy determination.

For clarification on straight run requirements, see Veris drawing SUB-4521 Pipe Straight Run Requirements.

## Flow Testing Verifies Accuracy

The flow test shown plots the data points of a full insert sensor compared to a partial insert sensor.

**The data confirms the accuracy of the partial insert to be within  $\pm 0.5\%$  of the full insert sensor.**

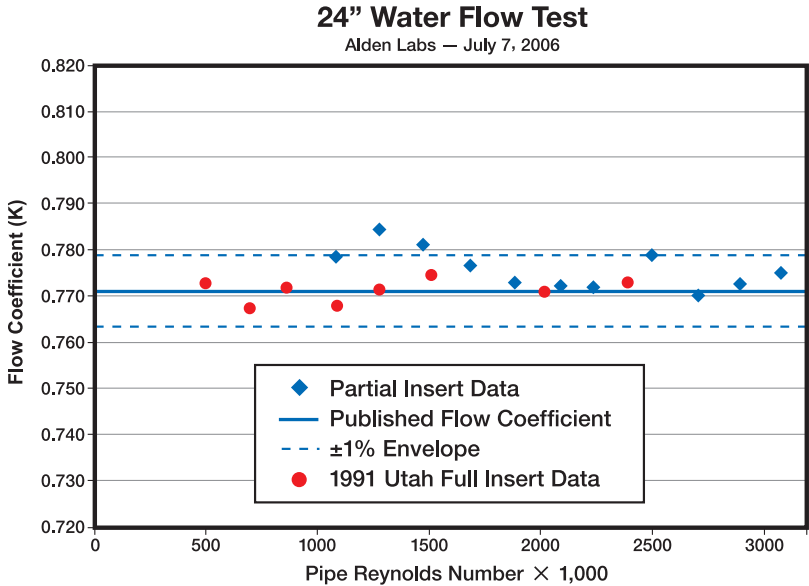

## How to Specify

The partial insert can be specified on Regular (V100), Hot Taps (V200 & V400) and Flanged (V500) models by adding the suffix **PI** to the model number. Example: V100PI-24" Sch Std-10-H-R

Veris will calculate the structural limits and supply the sensor designating the insertion length (ODH) from the pipe wall to the head of the sensor.

<b>Application:</b>	Cooling Water
<b>Pipe Size:</b>	60" (1524mm)
<b>Max. Flow Rate:</b>	100,000 GPM
<b>Model:</b>	Flanged Partial Insert



Designs, materials, weights and performance ratings are approximate and subject to change without notice. Visit [armstronginternational.com/veris](http://armstronginternational.com/veris) for up-to-date information.

**Armstrong** provides intelligent system solutions that improve utility performance, lower energy consumption, and reduce environmental emissions while providing an “enjoyable experience.”



**Armstrong International**  
North America • Latin America • India • Europe / Middle East / Africa • China • Pacific Rim  
[armstronginternational.com/veris](http://armstronginternational.com/veris)