

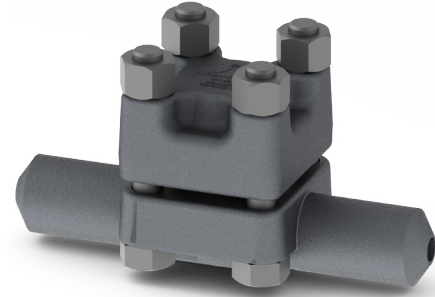

SH-1600 Bimetallic Steam Trap for Superheat Conditions

For Pressures to 1 750 psig (120.6 barg)...Cold Water Capacities to 6 500 lb/hr (2 950 kg/hr)

Steam Trapping and Steam Tracing Equipment

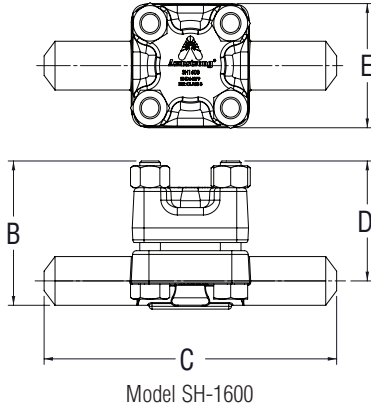

Description

SH Series superheat steam traps operate by the effect that rising temperature has on the bimetallic elements.

At start-up the valve is wide open, which allows a large volume of non-condensables and cold condensate to be removed from the system. When the trap reaches steam temperature, the bimetallic elements pull the valve into the seat closing the trap. The valve remains closed until the bimetallic elements cool, thus allowing the valve to crack open, vent the condensate and non-condensables, and then close again when steam temperature is reached.

The SH Series superheat steam traps adjust automatically to changing conditions. The SH-1600 series utilizes titanium valves and seats to ensure extremely long service life in the harsh environment of superheated steam systems.

Specifications

Steam trap shall be a bimetallic style. The trap shall be forged chrome-moly steel with integral stainless steel strainer, in-line repairable. The mechanism shall consist of a stacked nickel-chrome bimetal operator, with titanium valve and seat. The steam trap shall be capable of operation on low load and superheat applications throughout its pressure/temperature range.

How to Order

- Specify model number.
- Specify maximum operating pressure.
- Specify size and type of pipe connections.
- When flanges are required specify type of flange.

Maximum operating conditions

Maximum allowable pressure
(vessel design): 1 750 psig @ 970°F (120.6 barg @ 520°C)
Maximum operating pressure: 1 750 psig (120.6 barg)
Suggested minimum operating pressure: 600 psig (41 barg)

SH-1600		
Model	SH-1600	
Pipe Connections	in	mm
	3/4, 1	20, 25
"B" (Height)	5-3/16	148
"C" (End-to-End) - Socket Weld	12-3/8	315
"C" (End-to-End) - Butt Weld	12-3/8	315
"D" (Centerline to Top)	4-13/16	123
"E" (Width)	5	127
Weight in lb(Kg) - SW/BW	33 (15.0)	

Consult the factory for weight and dimensions of flanged connections.

Model SH-1600 Cold Water Capacity

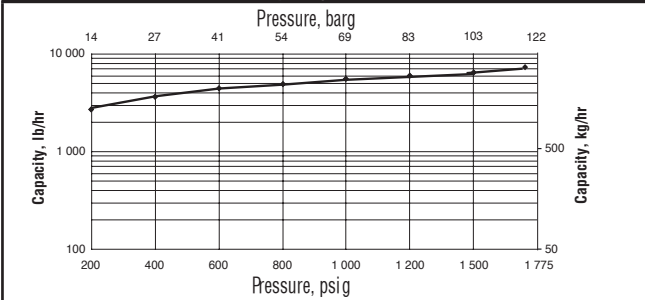

Model SH-1600 Pressure/Temperature Rating

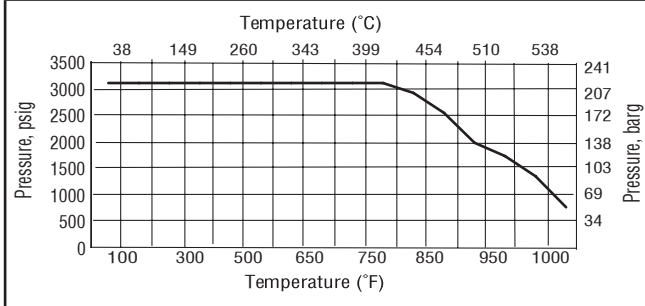

SH-1600

Connections	Socketweld, Buttweld, Flanged
Material	
Body and Cap	ASTM A-182 F22 Class 3
Valve	Titanium
Seat	
Bimetallic Elements	Nickel-chrome and stainless steel
Screen	Stainless Steel
Bolts	ASTM A193 Gr. B16
Nuts	ASTM A194 Gr. 7

Designs, materials, weights and performance ratings are approximate and subject to change without notice. Visit armstronginternational.com for up-to-date information.