

REFlex

Control Valve Technical Brochure

General Stem-Guided Control Valves

Sizes ½" - 12" (15mm - 300mm)

ANSI Class 150 - 900 (PN16 - 160)



CIRCOR | RTK

03025_REFlexTech Version 4 01/18

REflex Control Valve

Sizes ½" – 12" (15mm- 300mm) ANSI Class 150# - 900# (PN16 -160)

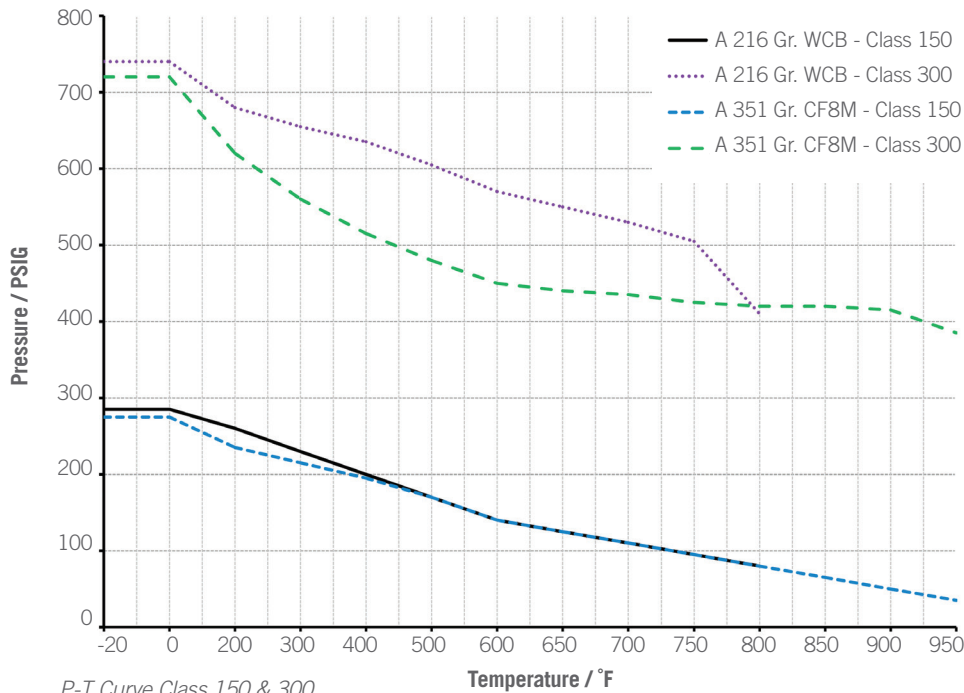

P-T Curve Class 150 & 300

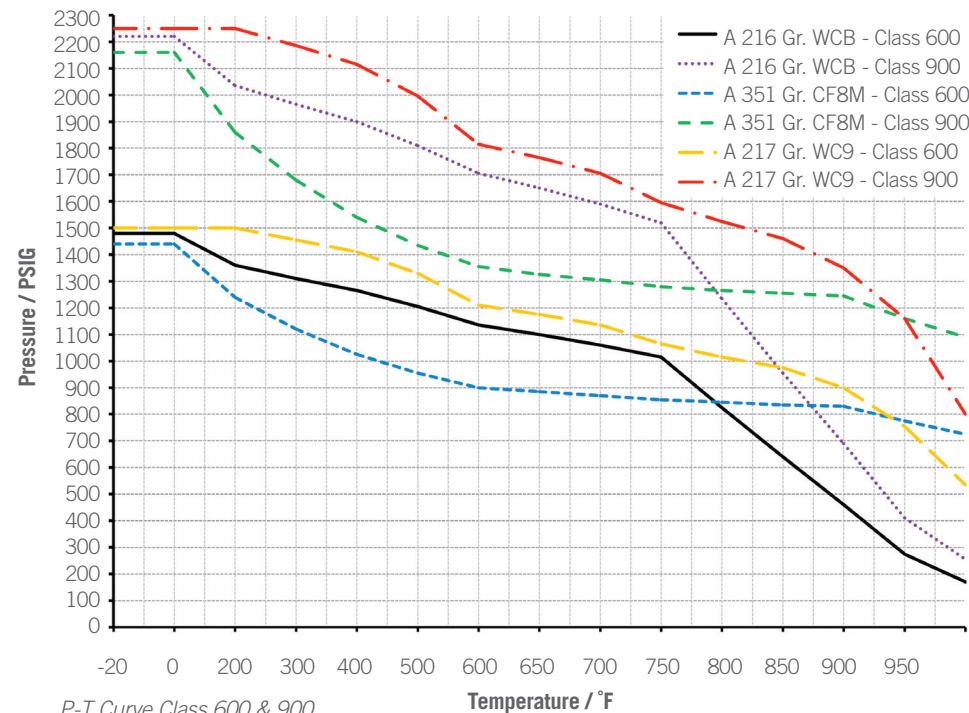

P-T Curve Class 600 & 900

➤ Broadest Range in the Industry

Offers more possibilities than any other valve family in the Industry

➤ Multiple Trim Options

Offering maximum versatility in flow control applications

➤ Wide variety of stem packings

Giving the best stem packing for the given application

➤ Different Trim Materials

Providing significantly longer service life

➤ High Flow capacities

Promote reduced body velocity and pressure losses

➤ Pneumatic Actuators

Compact and robust multi spring design

➤ Electric Actuators

Modular design covering a wide range of actuating forces

Materials

- Carbon Steel (WCB) Class 150 - 900
- 316 Stainless Steel (CF8M) Class 150 - 900
- Chrome Moly Steel (WC9) Class 600 & 900

Application Data

- Control Systems for Power, Chemical, Petrochemical, Pulp & Paper, Food and other Industries
- HVAC Systems
- Boiler Rooms
- Engineered skid packages (OEMs) such as thermal fluid systems, water treatment systems and many more

Options

- Reduced seat sizes for tighter control
- Noise and Cavitation reducing trim
- Soft seat sealing offering class VI shutoff
- Flanged, Butt Weld End, Threaded Connections
- Positioners (pneumatic & electric)

REflex Trim Design (Options)

Interchangeable plugs and seats offer maximum versatility in flow control applications.

Trim options include:



Two-Way On/Off

Characteristic: On/Off (Quick Opening)
 Flow direction: To open or to close
 This plug provides maximum flow with minimum pressure drop and is ideal when large flows are required just after opening.



Two-Way Parabolic

Characteristic: Linear or Equal Percentage
 Flow direction: To open
 This plug covers all Cv ranges and is especially suitable for low differential pressures. The equal percentage flow characteristic provides excellent low flow control.



Two-Way V-Port

Characteristic: Linear
 Flow direction: To open or to close
 This plug is ideally suited when actuator selection is critical, and the shorter stroke means smaller actuators can often be used.



Two-Way Perforated

Characteristic: Linear or Equal Percentage
 Flow direction: To open or to close
 The perforated plug is suitable for use where high differential pressures are present. It can also be used where noise is an issue, typically reducing the noise level by 10 dBA. The hardened version improves life expectancy in cavitation and/or flashing conditions.



Three-Way Mixing

Characteristic: Linear
 Flow direction: $A + B > AB$



Three-Way Diverting

Characteristic: Linear
 Flow direction: $AB > A, B$

All Plugs Available with Soft Seat, Offering Class VI Shutoff (Not Diverting)

REflex Packing Configurations (Options)

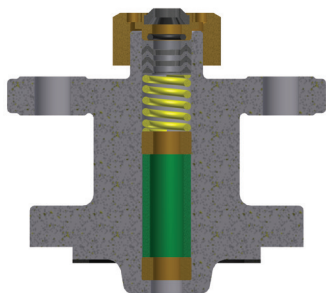

PTFE/Graphite (Standard)

Maintenance free chevron rings with pre stressed spring

- > Material: PTFE/Graphite
- > Temperature: -76°F to 482°F
- > Pressure: up to 900#
- > Application: Water, steam and other media

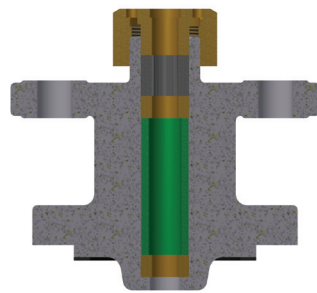

Pure Graphite

Consists of pure flexible graphite rings and two anti-extrusion Inconel wire reinforced flexible graphite rings

- > Material: Graphite
- > Temperature: -76°F to 986°F
- > Pressure: up to 900#
- > Application: Water, steam and other media

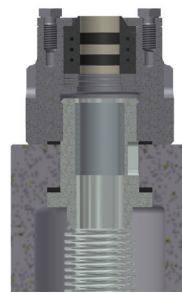

Bellows Seal

Maintenance-free metal bellows stem seal with safety packing

- > Material: Stainless Steel Bellows
- > Temperature: -76°F to 662°F
- > Pressure: up to 300#
- > Application: Thermal Oil, Ammonia

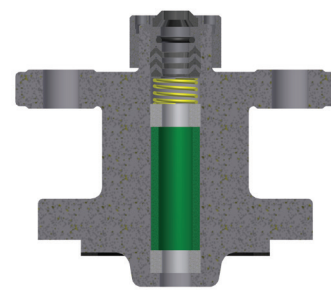

Chloroprene

Maintenance free chevron rings with pre stressed spring

- > Material: Chloroprene
- > Temperature: -40°F to 212°F
- > Pressure: up to 300#
- > Application: Refrigerants

REflex Specifications

Body Assembly:

Style: Single seated, top entry bolted bonnet, globe style body, stem guided unbalanced plug

Size, Ratings:

Two Way*

150#	½" – 12"
300#	½" – 12"
600#	½" – 4"
900#	1" – 4"

*2½" only available in 150# & 300#

Three Way

150#	1" – 12"
300#	1" – 12"

Body Materials:

Carbon Steel ASTM A216 WCB
-20°F to 797°F (-29°C to 425°C)
(class 150-900)

316 Stainless Steel ASTM A351 CF8M
-20°F to 995°F (-29°C to 535°C)
(class 150-900)

Chrome Moly ASTM A217 WC9
-20°F to 995°F (-29°C to 535°C)
(class 600+900)

Bonnet:

Bolted bonnet, bonnet with cooling fins for high temperatures, extended bonnet for bellows seal

End Connections:

Flanges according to ANSI B16.5 RF
(raised face)

Butt Weld Ends according to ANSI B16.25-2007

Threaded NPT Connections (up to 2")
Two Way Only

Dimensions (Face to Face) per ANSI/ISA-S75.03
(DIN EN 558-1)

Stem Packing:

PTFE/Graphite -76°F to 482°F (-60°C to 250°C)

Pure graphite -76°F to 986°F (-60°C to 530°C)

Bellows seal -76°F to 662°F (-60°C to 350°C)

Chloroprene -40°F to 212°F (-40°C to 110°C)

Gaskets:

Spiral Wound 316L/Graphite (Standard)

Max. 986°F (530°C)

PTFE (food & beverage, oxygen, ozone service)

Max. 482°F (250°C)

Grooved gasket B7A (refrigeration)

-328°F to 572°F (-200°C to 300°C)

Plug Types & Flow Characteristics:

Two way:

On/Off plug (Quick Opening)

Parabolic Plug (Equal Percentage or Linear)

V Port Plug (Linear)

Perforated Plug (Equal Percentage or Linear)

Three way:

Mixing Plug (Linear)

Diverting Plug (Linear)

Trim Materials:

Plug 1.4122 (Martensitic)

Stem and Seat AISI 316 Ti

Optional:

Plug AISI 316 Ti

Parabolic Plug stellite or hardened

Perforated Plug hardened

Shutoff Class (ANSI/FCI 70-2):

Standard Trim Class IV (<0.01% Cv) metal seat

Standard Trim Class IV - S2 (<0.005% Cv)

metal seat lapped in

Soft Seat Class VI (tight closing) with PTFE
max+ 392°F

Diverting Plug port B Class III (<0.1% Cv)

Actuators:

Electric:

REact 15 (1.5 kN) max. 337 lbs force
max. stroke 1³/₈"
stem ½"

REact 30 (3 kN) max. 675 lbs force
max. stroke 1½"
stem ½"

REact 60 (6 kN) max. 1350 lbs force
max. stroke 2³/₈"
stem ½"

REact 100 (10 kN) max. 2250 lbs force
max. stroke 3"
stem ½"

ST5106 (15 kN) max. 3370 lbs force
max. stroke 3"
stem 1¼"

Pneumatic:

ST6135.B6 (43 Inch²) max. 495 lbs force
max. stroke 1³/₈"
stem ½"

ST6160.A6 (82 Inch²) max. 900 lbs force
max. stroke 1½"
stem ½"

ST6160.C6 (82 Inch²) max. 720 lbs force
max. stroke 2³/₈"
stem ½"

ST6175.B6 (155 Inch²) max. 3600 lbs force
max. stroke 2³/₈"
stem 1¼"

ST6175.C6 (155 Inch²) max. 4270 lbs force
max. stroke 4"
stem 1¼"

Optional:

Hydraulic emergency closing unit
for electric actuators

Customer specified actuators
(Electric, Pneumatic and Hydraulic)

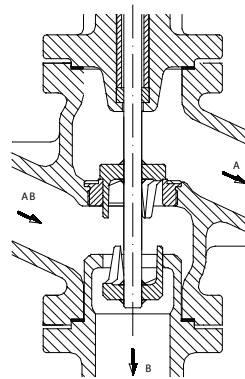

Diverting

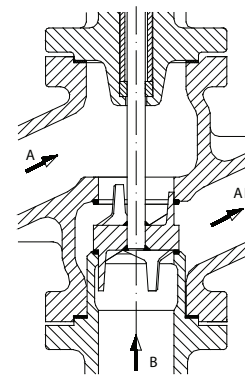

Mixing

REflex Material Specifications

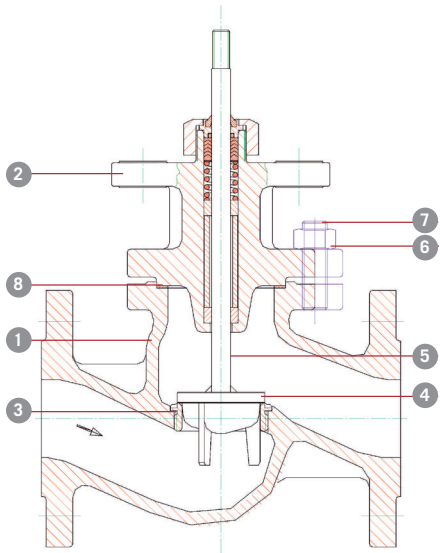

Item Description	Material	Material Specs (ANSI Equivalent)
1 ... Body	Carbon Steel	.ASTM A216 Gr WCB
	Stainless Steel	.ASTM A351 Gr CF8M
	Chrome-Moly Steel	.ASTM A217 Gr WC9
2 ... Bonnet	Carbon Steel	.ASTM A216 WCB
	Stainless Steel	.ASTM A351 Gr CF8M
	Chrome-Moly Steel	.ASTM A217 Gr WC9
3 ... Seat Ring	Stainless Steel	.1.4571 (AISI 316 Ti)
4 ... Plug	Stainless Steel	.1.4122
5 ... Stem	Stainless Steel	.1.4571 (AISI 316 Ti)
	Carbon Steel	.CK 35YK
6 ... Nut	Stainless Steel	.A2-70
	Chrome-Moly Steel	.21CrMoV57 GA
	Carbon Steel	.CK 35YK
7 ... Stud	Stainless Steel	.A2-70
	Chrome-Moly Steel	.24CrMo5 G
	Graphite+Stainless Steel	.Graphite + 1.4401
9 ... B-flange (3-Way)	Carbon Steel	.ASTM A216 WCB
	Stainless Steel	.ASTM A351 Gr CF8M

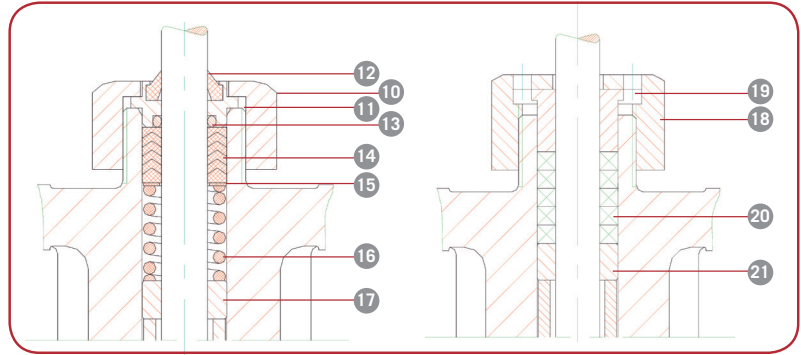
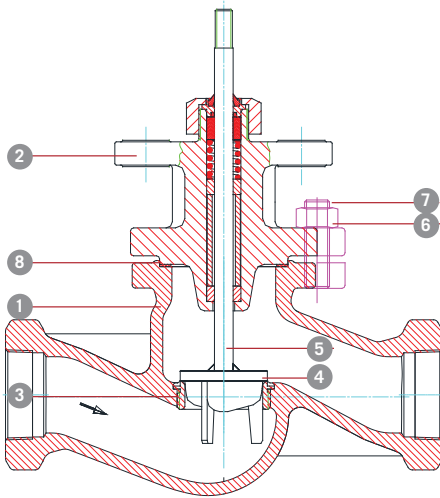

Item Description	Material	Material Specs (ANSI Equivalent)
Stem Packing PTFE/Graphite		
10 ... Clamping Nut	Brass	.CuZn39Pb3 (ASTM C 38500)
11 ... Packing Follower	Red Brass	.CuSn7ZnPb (ASTM C 93200)
12 ... Wiper Ring	Nitrile Butadiene Rubber	.NBR 90
13 ... O Ring	Nitrile Butadiene Rubber	.NBR 90
14 ... Packing (Chevron rings)	PTFE/Graphite	.PTFE/Graphite
15 ... Washer	Stainless Steel	.1.4310 (AISI 301)
16 ... Spring	Stainless Steel	.1.4310 (AISI 301)
17 ... Guide Bushing	Red Brass	.CuSn7ZnPb (ASTM C 93200)
Stem Packing Graphite		
18 ... Clamping Nut	Brass	.CuZn39Pb3 (ASTM C 38500)
19 ... Packing Follower	Red Brass	.CuSn7ZnPb (ASTM C 93200)
20 ... Packing	Graphite	.Graphite
21 ... Guide Bushing	Red Brass	.CuSn7ZnPb (ASTM C 93200)

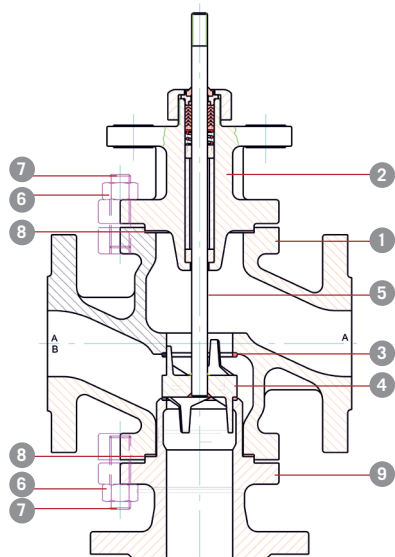

REFlex Cv Values

Parabolic plug																				
ANSI	Seat [Inch]																			
NPS	1/8	1/4	1/4	3/8	3/8	1/2	3/4	1	1 1/4	1 1/2	2	2 1/2	3	4	5	6	8	10	10	12
1/2"	0.58	1.2	2	2.4	3.1	3.8														
3/4"	0.58	1.2	2	2.9	4.3	4.9	7													
1"	0.58	1.2	2	2.9	4.6	6	8.7	10.7												
1 1/2"	0.58	1.2	2	2.9	5.1	7.9	13	17	22	28										
2"		1.2	2	2.9	5.1	7.9	14	21	28	35	43									
2 1/2"			2	2.9	5.1	7.9	14	22	33	43	55	73								
3"						7.9	14	22	36	52	67	92	110							
4"							14	22	36	56	81	115	140	172						
6"										56	87	147	208	271	339	386				
8"											87	147	225	325	425	487	687			
10"												147	225	350	508	611	866	982	1074	
12"													225	350	540	655	943	1133	1306	1546
Stroke [Inch]	1						1 1/4				1 3/8		2		2 3/8		3		4	

Perforated plug																				
ANSI	Seat [Inch]																			
NPS	3/8	1/2	3/4	1	1 1/4	1 1/2	2	2 1/2	3	4	5	6	8	8	10	10	12			
1/2"	1.9	3																		
3/4"	2	3.1	5.3																	
1"	2	3.1	5.6	8.4																
1 1/2"	2	3.1	5.6	8.8	14	22														
2"	2	3.1	5.6	8.8	14	22	34													
2 1/2"			5.6	8.8	15	22	35	57												
3"				8.8	15	23	35	60	86											
4"				8.8	15	23	35	60	91	135										
6"						23	35	60	91	142	220	303								
8"							35	60	91	142	220	317	467	540						
10"								60	91	142	220	317	479	564	791	842				
12"									91	142	220	317	479	564	841	910	1223			
Stroke [Inch]	1			1 1/4			1 1/2		2		2 3/8		3		4		3		4	

V-port plug																			
ANSI	Seat [Inch]																		
NPS	3/4	1	1 1/4	1 1/2	2	2 1/2	3	4	5	6	8	10	12						
3/4"	7																		
1"	8.7	10.7																	
1 1/2"	13	17	22	28															
2"		21	28	35	43														
2 1/2"		22	33	43	55	73													
3"			36	52	67	92	110												
4"				56	81	115	140	172											
6"						147	208	271	339	386									
8"							225	325	425	487	687								
10"								350	508	611	866	1074							
12"									540	655	943	1306	1546						
Stroke [Inch]	1/2					1		1 1/4		1 3/8		1 1/2		2 3/8		3		4	

REflex Cv Values (continued)

On-off plug																
ANSI	Seat [Inch]															
	¼	⅜	½	¾	1	1¼	1½	2	2½	3	4	5	6	8	10	12
NPS																
½"	2	3.1	3.8													
¾"	2	4.3	4.9	7												
1"	2	4.7	6	8.7	10.7											
1½"			7.9	13	17	22	28									
2"				14	21	28	35	43								
2½"					22	33	43	55	73							
3"						36	52	67	92	110						
4"							56	81	115	140	172					
6"									147	208	271	339	386			
8"										225	325	425	487	687		
10"											350	508	611	866	1074	
12"												540	655	943	1306	1546
Stroke [Inch.]					½					1	1¼	1⅜	1½	2⅜	3	4

Three Way						
ANSI	Mixing plug			Diverting plug		
	Stroke [Inch]	Seat [Inch]	Cv [gpm]	Stroke [Inch]	Seat [Inch]	Cv [gpm]
NPS						
1"	½	1¼	10.7	½	1	8.7
1½"		1½	28		1¼	22
2"		2	43		1½	35
2½"		2½	73		2	55
3"	1	3	110		2½	92
4"	1¼	4	172	1	3	140
6"	1½	6	386	1⅜	5	339
8"	2⅜	8	687	1½	6	487
10"	3	10	1074	2⅜	8	867
12"	4	12	1546	3	10	1306

REflex Shutoff Tables

Electric, Flow to Open/Close Stem Packing PTFE/Graphite																			
Max. permissible shutoff pressures (PSIG) P2 = 0																			
	Seat Inch		1/8	1/4	3/8	1/2	3/4	1	1 1/4	1 1/2	2	2 1/2	3	4	5	6	8	10	12
	Stroke Inch	Parabolic	1	1	1	1	1	1	1 1/4	1 1/4	1 1/4	1 3/8	1 3/8	1 3/8/2*	2	2 3/8	3	4	4
		On/Off, V port, Mixing	1/2	1/2	1/2	1/2	1/2	1/2	1/2	1/2	1/2	1/2	1	1 1/4	1 3/8	1 1/2	2 3/8	3	4
		Diverting						1/2	1/2	1/2	1/2	1/2	1/2	1	1 1/4	1 3/8	1 1/2	2 3/8	3
		Perforated			1	1	1	1	1 1/4	1 1/4	1 1/4	1 1/2	2	2	2 3/8	3	4	4	4
Actuator																			
REact 15	1 3/8" (35mm)		750	750	750	750	435	262	148	85	47	21							
REact 30	1 1/2" (40mm)		750	750	750	750	750	700	417	258	158	87	54	31					
REact 60	2 3/8" (60mm)		750	750	750	750	750	750	750	605	380	218	140	87	52	35			
REact 100	3" (80mm)		750	750	750	750	750	750	750	750	675	392	255	160	99	67			
ST5106	3" (80mm)			750	750	750	750	750	750	750	750	585	382	241	150	103	55	35	23



*Valves with 1/2" Stem, Stroke 1 3/8"
Valves with 1 1/4" Stem, Stroke 2"

Note – Shutoff values for PTFE/Graphite packing. Consult factory for shutoff ratings when using other packing types.

REflex Shutoff Tables (continued)

Pneumatic, Spring closes on Air Failure [Reverse Acting] Flow-to-Open. Stem Packing PTFE/Graphite																			
Max permissible shutoff pressures (PSIG) P2 = 0																			
	Seat Inch		1/8	1/4	3/8	1/2	3/4	1	1 1/4	1 1/2	2	2 1/2	3	4	5	6	8	10	12
	Stroke Inch	Parabolic	1	1	1	1	1	1	1 1/4	1 1/4	1 1/4	1 3/8	1 3/8	1 3/8/2*	2	2 3/8	3	4	4
		On/Off, V port, Mixing	1/2	1/2	1/2	1/2	1/2	1/2	1/2	1/2	1/2	1/2	1	1 1/4	1 3/8	1 1/2	2 3/8	3	4
		Diverting							1/2	1/2	1/2	1/2	1/2	1	1 1/4	1 3/8	1 1/2	2 3/8	3
		Perforated			1	1	1	1	1 1/4	1 1/4	1 1/4	1 1/2	2	2	2 3/8	3	4	4	4
Actuator	Air sup. PSIG																		
ST6135.B6-2G Stroke 1 3/8" (35mm) Stem 1/2" Spring-range 3-15 psi Actuator Code: BCA_	30	Parabolic	750	750	346	197	88	41	4										
		On/Off, V port, Mixing	750	750	667	402	203	115	58	28	10								
		Diverting						115	58	28	10								
		Perforated			346	197	88	41	4										
	60	Parabolic	750	750	398	230	106	53	4										
		On/Off, V port, Mixing	750	750	667	402	203	115	58	28	10								
		Diverting						115	58	28	10								
		Perforated			398	230	106	53	4										
	90	Parabolic	750	750	398	230	106	53	4										
		On/Off, V port, Mixing	750	750	667	402	203	115	58	28	10								
		Diverting						115	58	28	10								
		Perforated			398	230	106	53	4										
ST6135.B6-6G Stroke 1 3/8" (35mm) Stem 1/2" Spring-range 11.6-43.5 psi Actuator Code: BDA_	60	Parabolic	750	750	750	750	750	618	310	189	114	48	27	14					
		On/Off, V port, Mixing	750	750	750	750	750	750	473	293	180	100	44	19					
		Diverting						750	473	293	180	100	62	25					
		Perforated			750	750	750	618	310	189	114								
	90	Parabolic	750	750	750	750	750	618	310	189	114	48	27	14					
		On/Off, V port, Mixing	750	750	750	750	750	750	473	293	180	100	44	19					
		Diverting						750	473	293	180	100	62	25					
		Perforated			750	750	750	618	310	189	114								
	ST6160.A6-6G Stroke 1 1/2"(40mm) Stem 1/2" Spring-range 11.6-40.6 psi Actuator Code: CEA_	60	Parabolic	750	750	750	750	750	750	547	343	161	102	62					
			On/Off, V port, Mixing	750	750	750	750	750	750	750	491	284	145	76	37	18			
			Diverting						750	750	750	491	284	183	89	46	23		
			Perforated			750	750	750	750	547	343	131							
90		Parabolic	750	750	750	750	750	750	750	547	343	161	102	62					
		On/Off, V port, Mixing	750	750	750	750	750	750	750	491	284	145	76	37	18				
		Diverting						750	750	750	491	284	183	89	46	23			
		Perforated			750	750	750	750	547	343	131								

*Valves with 1/2" Stem, Stroke 1 3/8"

Valves with 1 1/4" Stem, Stroke 2"

Note – Shutoff values for PTFE/Graphite packing. Consult factory for shutoff ratings when using other packing types.



REflex Shutoff Tables (continued)

Pneumatic, Spring closes on Air Failure [Reverse Acting] Flow-to-Open. Stem Packing PTFE/Graphite																					
Max permissible shutoff pressures (PSIG) P2 = 0																					
	Seat Inch		1/8	1/4	3/8	1/2	3/4	1	1 1/4	1 1/2	2	2 1/2	3	4	5	6	8	10	12		
	Stroke Inch	Parabolic	1	1	1	1	1	1	1 1/4	1 1/4	1 1/4	1 3/8	1 3/8	1 3/8/2*	2	2 3/8	3	4	4		
		On/Off, V port, Mixing	1/2	1/2	1/2	1/2	1/2	1/2	1/2	1/2	1/2	1/2	1	1 1/4	1 3/8	1 1/2	2 3/8	3	4		
		Diverting							1/2	1/2	1/2	1/2	1/2	1	1 1/4	1 3/8	1 1/2	2 3/8	3		
		Perforated			1	1	1	1	1 1/4	1 1/4	1 1/4	1 1/2	2	2	2 3/8	3	4	4	4		
Actuator	Air sup. PSIG																				
ST6160.C6-3G Stroke 2 3/8" (60mm) Stem 1/2" Spring-range 4.4-18.9 psi Actuator Code: CFA_	30	Parabolic	750	750	750	750	750	750	750	418	259	158	76	46	26	5					
		On/Off, V port, Mixing	750	750	750	750	750	750	750	554	345	214	120	60	30	13	5				
		Diverting							750	554	345	214	120	75	35	16	7				
		Perforated			750	750	750	750	750	418	259	158	65	24	12						
	60	Parabolic	750	750	750	750	750	750	750	418	259	158	76	46	26	5					
		On/Off, V port, Mixing	750	750	750	750	750	750	750	554	345	214	120	60	30	13	5				
		Diverting							750	554	345	214	120	75	35	16	7				
		Perforated			750	750	750	750	750	418	259	158	65	24	12						
	90	Parabolic	750	750	750	750	750	750	750	418	259	158	76	46	26	5					
		On/Off, V port, Mixing	750	750	750	750	750	750	750	554	345	214	120	60	30	13	5				
		Diverting							750	554	345	214	120	75	35	16	7				
		Perforated			750	750	750	750	750	418	259	158	65	24	12						
ST6160.C6-7G Stroke 2 3/8" (60mm) Stem 1/2" Spring-range 10.2-43.5 psi Actuator Code: CGA_	60	Parabolic	750	750	750	750	750	750	750	697	439	227	145	89	33	11					
		On/Off, V port, Mixing	750	750	750	750	750	750	750	750	572	332	183	100	54	31					
		Diverting							750	750	572	332	215	113	61	36					
		Perforated			750	750	750	750	750	697	439	201	94	56	19						
	90	Parabolic	750	750	750	750	750	750	750	697	439	227	145	89	33	11					
		On/Off, V port, Mixing	750	750	750	750	750	750	750	750	572	332	183	100	54	31					
		Diverting							750	750	572	332	215	113	61	36					
		Perforated			750	750	750	750	750	697	439	201	94	56	19						
	ST6175.B6-3D Stroke 2 3/8" (60mm) Stem 1 1/4" Spring-range 10.2-30.5 psi Actuator Code: DJA_	60	Parabolic								750	742	400	259	162	74	37				
			On/Off, V port, Mixing								750	750	531	303	176	101	62	19			
			Diverting								750	750	531	346	190	110	68	33	10		
			Perforated								750	742	367	195	121	57					
90		Parabolic								750	742	400	259	162	74	37					
		On/Off, V port, Mixing								750	750	531	303	176	101	62	19				
		Diverting								750	750	531	346	190	110	68	33	10			
		Perforated								750	742	367	195	121	57						

*Valves with 1/2" Stem, Stroke 1 3/8"
 Valves with 1 1/4" Stem, Stroke 2"

Note – Shutoff values for PTFE/Graphite packing. Consult factory for shutoff ratings when using other packing types.



REflex Shutoff Tables (continued)

Pneumatic, Spring closes on Air Failure [Reverse Acting] Flow-to-Open. Stem Packing PTFE/Graphite																				
Max permissible shutoff pressures (PSIG) P2 = 0																				
	Seat Inch		1/8	1/4	3/8	1/2	3/4	1	1 1/4	1 1/2	2	2 1/2	3	4	5	6	8	10	12	
	Stroke Inch	Parabolic	1	1	1	1	1	1	1 1/4	1 1/4	1 1/4	1 3/8	1 3/8	1 3/8/2*	2	2 3/8	3	4	4	
		On/Off, V port, Mixing	1/2	1/2	1/2	1/2	1/2	1/2	1/2	1/2	1/2	1/2	1	1 1/4	1 3/8	1 1/2	2 3/8	3	4	
		Diverting						1/2	1/2	1/2	1/2	1/2	1/2	1	1 1/4	1 3/8	1 1/2	2 3/8	3	
		Perforated			1	1	1	1	1 1/4	1 1/4	1 1/4	1 1/2	2	2	2 3/8	3	4	4	4	
Actuator	Air sup. PSIG																			
ST6175.B6-7D Stroke 2 3/8" (60mm) Stem 1 1/4" Spring-range 23.2-68.2 psi Actuator Code: DLA_	90	Parabolic								750	750	750	671	426	204	111				
		On/Off, V port, Mixing									750	750	750	750	453	269	169	60		
		Diverting									750	750	750	750	481	287	185	93	37	
		Perforated									750	750	750	512	324	163				
ST6175.C6-3D Stroke 4" (100mm) Stem 1 1/4" Spring-range 11.6-30.5 psi Actuator Code: DNA_	60	Parabolic								750	750	520	339	213	116	70	33	13	8	
		On/Off, V port, Mixing									750	750	607	368	222	133	87	37	19	8
		Diverting									750	750	607	397	232	139	91	46	22	12
		Perforated									750	750	498	296	185	104	62	23	13	8
	90	Parabolic									750	750	520	339	213	116	70	33	13	8
		On/Off, V port, Mixing									750	750	607	368	222	133	87	37	19	8
		Diverting									750	750	607	397	232	139	91	46	22	12
		Perforated									750	750	498	296	185	104	62	23	13	8
ST6175.C6-7D Stroke 4" (100mm) Stem 1 1/4" Spring-range 27.6-68.2 psi Actuator Code: DQA_	90	Parabolic								750	750	750	750	541	299	197	90	46	31	
		On/Off, V port, Mixing									750	750	750	750	555	343	230	109	56	31
		Diverting									750	750	750	750	569	352	236	127	68	38
		Perforated									750	750	750	743	472	287	165	74	46	31

*Valves with 1/2" Stem, Stroke 1 3/8"

Valves with 1 1/4" Stem, Stroke 2"

Note – Shutoff values for PTFE/Graphite packing. Consult factory for shutoff ratings when using other packing types.



REflex Shutoff Tables (continued)

Pneumatic, Spring opens on Air Failure [Direct Acting] Flow-to-Open. Stem Packing PTFE/Graphite Max permissible shutoff pressures (PSIG) P2 = 0																				
	Seat Inch		1/8	1/4	3/8	1/2	3/4	1	1 1/4	1 1/2	2	2 1/2	3	4	5	6	8	10	12	
	Stroke Inch	Parabolic	1	1	1	1	1	1	1 1/4	1 1/4	1 1/4	1 3/8	1 3/8	1 3/8/2*	2	2 3/8	3	4	4	
		On/Off, V port, Mixing	1/2	1/2	1/2	1/2	1/2	1/2	1/2	1/2	1/2	1/2	1/2	1	1 1/4	1 3/8	1 1/2	2 3/8	3	4
		Diverting							1/2	1/2	1/2	1/2	1/2	1/2	1	1 1/4	1 3/8	1 1/2	2 3/8	3
		Perforated			1	1	1	1	1 1/4	1 1/4	1 1/4	1 1/2	2	2	2 3/8	3	4	4	4	
Actuator	Air sup. PSIG																			
ST6135.B6-2G Stroke 1 3/8" (35mm) Stem 1/2" Spring-range 3-15 psi Actuator Code: BCB_	30	Parabolic	750	750	750	750	686	439	235	151	96	50	33	21						
		On/Off, V port, Mixing	750	750	750	750	750	541	330	211	135	80	43	24						
		Diverting					750	541	330	211	135	80	43	24						
		Perforated			750	750	686	439	235	151	96									
	60	Parabolic	750	750	750	750	750	750	750	497	318	181	119	76						
		On/Off, V port, Mixing	750	750	750	750	750	750	750	558	357	211	129	80						
		Diverting					750	750	750	558	357	211	139	83						
		Perforated			750	750	750	750	750	497	318									
	90	Parabolic	750	750	750	750	750	750	750	750	540	312	206	132						
		On/Off, V port, Mixing	750	750	750	750	750	750	750	750	579	342	216	135						
		Diverting					750	750	750	750	579	342	226	138						
		Perforated			750	750	750	750	750	540										
ST6135.B6-6G Stroke 1 3/8" (35mm) Stem 1/2" Spring-range 11.6-43.5 psi Actuator Code: BDB_	30	Parabolic																		
		On/Off, V port, Mixing	346	87	38	25	14	9												
		Diverting					14	9												
		Perforated																		
	60	Parabolic	750	750	750	750	750	616	290	185	119	50	33	21						
		On/Off, V port, Mixing	750	750	750	750	750	547	350	224	132	60	30							
		Diverting					750	547	350	224	132	87	39							
		Perforated			750	750	616	290	185	119										
	90	Parabolic	750	750	750	750	750	750	750	532	340	181	119	76						
		On/Off, V port, Mixing	750	750	750	750	750	750	750	696	446	264	147	85						
		Diverting					750	696	446	264	147	94								
		Perforated			750	750	750	750	532	340										

*Valves with 1/2" Stem, Stroke 1 3/8"
 Valves with 1 1/4" Stem, Stroke 2"

Note – Shutoff values for PTFE/Graphite packing. Consult factory for shutoff ratings when using other packing types.

REflex Shutoff Tables (continued)

Pneumatic, Spring opens on Air Failure [Direct Acting] Flow-to-Open. Stem Packing PTFE/Graphite																				
Max permissible shutoff pressures (PSIG) P2 = 0																				
	Seat Inch		1/8	1/4	3/8	1/2	3/4	1	1 1/4	1 1/2	2	2 1/2	3	4	5	6	8	10	12	
	Stroke Inch	Parabolic	1	1	1	1	1	1	1 1/4	1 1/4	1 1/4	1 3/8	1 3/8	1 3/8/2*	2	2 3/8	3	4	4	
		On/Off, V port, Mixing	1/2	1/2	1/2	1/2	1/2	1/2	1/2	1/2	1/2	1/2	1/2	1	1 1/4	1 3/8	1 1/2	2 3/8	3	4
		Diverting							1/2	1/2	1/2	1/2	1/2	1/2	1	1 1/4	1 3/8	1 1/2	2 3/8	3
		Perforated			1	1	1	1	1 1/4	1 1/4	1 1/4	1 1/2	2	2	2 3/8	3	4	4	4	
Actuator	Air sup. PSIG																			
ST6160.A6-6G Stroke 1 1/2" (40mm) Stem 1/2" Spring-range 11.6-40.6 psi Actuator Code: CEB_	30	Parabolic																		
		On/Off, V port, Mixing	750	750	750	628	353	226	138	88	57	33								
		Diverting					353	226	138	88	57	33	22							
		Perforated																		
	60	Parabolic	750	750	750	750	750	750	702	449	287	143	94	60						
		On/Off, V port, Mixing	750	750	750	750	750	750	750	666	426	252	130	72	39	22				
		Diverting					750	750	750	666	426	252	166	83	46	27				
		Perforated			750	750	750	750	702	449	287	115								
	90	Parabolic	750	750	750	750	750	750	750	750	657	361	239	153						
		On/Off, V port, Mixing	750	750	750	750	750	750	750	750	750	471	275	164	98	63				
		Diverting					750	750	750	750	750	471	311	176	105	68				
		Perforated			750	750	750	750	750	750	657	334								
ST6160.C6-3G Stroke 2 3/8" (60mm) Stem 1/2" Spring-range 4.4-18.9 psi Actuator Code: CFB_	30	Parabolic	750	750	750	750	750	750	476	305	195	107	70	45	21	11				
		On/Off, V port, Mixing	750	750	750	750	750	750	589	377	241	143	82	49	29	18				
		Diverting					750	750	589	377	241	143	94	52	31	20				
		Perforated			750	750	750	750	476	305	195	97	52	34	16					
	60	Parabolic	750	750	750	750	750	750	750	750	564	325	215	137	81	52				
		On/Off, V port, Mixing	750	750	750	750	750	750	750	750	611	361	226	141	88	59				
		Diverting					750	750	750	750	611	361	239	145	90	61				
		Perforated			750	750	750	750	750	750	567	315	197	126	76					
	90	Parabolic	750	750	750	750	750	750	750	750	544	359	230	140	94					
		On/Off, V port, Mixing	750	750	750	750	750	750	750	750	580	371	233	147	100					
		Diverting					750	750	750	750	580	383	237	149	102					
		Perforated			750	750	750	750	750	750	534	341	218	135						

*Valves with 1/2" Stem, Stroke 1 3/8"

Valves with 1 1/4" Stem, Stroke 2"

Note – Shutoff values for PTFE/Graphite packing. Consult factory for shutoff ratings when using other packing types.



REflex Shutoff Tables (continued)

Pneumatic, Spring opens on Air Failure [Direct Acting] Flow-to-Open. Stem Packing PTFE/Graphite																			
Max permissible shutoff pressures (PSIG) P2 = 0																			
	Seat Inch		1/8	1/4	3/8	1/2	3/4	1	1 1/4	1 1/2	2	2 1/2	3	4	5	6	8	10	12
	Stroke Inch	Parabolic	1	1	1	1	1	1	1 1/4	1 1/4	1 1/4	1 3/8	1 3/8	1 3/8/2*	2	2 3/8	3	4	4
		On/Off, V port, Mixing	1/2	1/2	1/2	1/2	1/2	1/2	1/2	1/2	1/2	1/2	1	1 1/4	1 3/8	1 1/2	2 3/8	3	4
		Diverting						1/2	1/2	1/2	1/2	1/2	1/2	1	1 1/4	1 3/8	1 1/2	2 3/8	3
		Perforated			1	1	1	1	1 1/4	1 1/4	1 1/4	1 1/2	2	2	2 3/8	3	4	4	4
Actuator	Air sup. PSIG																		
ST6160.C6-7G Stroke 2 3/8" (60mm) Stem 1/2" Spring-range 10.2-43.5 psi Actuator Code: CGB_	30	Parabolic	750	750	629	402	226	145											
		On/Off, V port, Mixing	750	750	750	750	665	426	260	166	106	63	14						
		Diverting					665	426	260	106	106	63	42	9					
		Perforated					226	145											
	60	Parabolic	750	750	750	750	750	750	750	579	371	198	131	84	37	18			
		On/Off, V port, Mixing	750	750	750	750	750	750	750	743	476	282	158	93	54	33			
		Diverting					750	750	750	743	476	282	186	101	59	37			
		Perforated					750	750	750	579	371	178	89	57	25				
	90	Parabolic	750	750	750	750	750	750	750	750	740	417	275	176	96	59			
		On/Off, V port, Mixing	750	750	750	750	750	750	750	750	750	500	303	185	113	74			
		Diverting					750	750	750	750	750	500	330	194	118	78			
		Perforated			750	750	750	750	750	750	740	396	233	149	84				
ST6175.B6-3D Stroke 2 3/8" (60mm) Stem 1 1/4" Spring-range 10.2-30.5 psi Actuator Code: DJB_	30	Parabolic								443	284	126	83						
		On/Off, V port, Mixing								750	491	290	139	71	34	16			
		Diverting								750	491	290	192	89	45	24	9		
		Perforated								443	284	87							
	60	Parabolic								750	750	750	545	297	190	117			
		On/Off, V port, Mixing								750	750	750	600	366	223	148	66		
		Diverting								750	750	750	653	384	235	155	83	42	
		Perforated								750	750	750	464	297	168				
	90	Parabolic								750	750	750	750	593	379	248			
		On/Off, V port, Mixing								750	750	750	750	662	412	279	140		
		Diverting								750	750	750	750	680	424	286	157	89	
		Perforated								750	750	750	750	593	357				

*Valves with 1/2" Stem, Stroke 1 3/8"
 Valves with 1 1/4" Stem, Stroke 2"

Note – Shutoff values for PTFE/Graphite packing. Consult factory for shutoff ratings when using other packing types.

REflex Shutoff Tables (continued)

Pneumatic, Spring opens on Air Failure [Direct Acting] Flow-to-Open. Stem Packing PTFE/Graphite																					
Max permissible shutoff pressures (PSIG) P2 = 0																					
	Seat Inch		1/8	1/4	3/8	1/2	3/4	1	1 1/4	1 1/2	2	2 1/2	3	4	5	6	8	10	12		
	Stroke Inch	Parabolic	1	1	1	1	1	1	1 1/4	1 1/4	1 1/4	1 3/8	1 3/8	1 3/8/2*	2	2 3/8	3	4	4		
		On/Off, V port, Mixing	1/2	1/2	1/2	1/2	1/2	1/2	1/2	1/2	1/2	1/2	1	1 1/4	1 3/8	1 1/2	2 3/8	3	4		
		Diverting							1/2	1/2	1/2	1/2	1/2	1	1 1/4	1 3/8	1 1/2	2 3/8	3		
		Perforated			1	1	1	1	1 1/4	1 1/4	1 1/4	1 1/2	2	2	2 3/8	3	4	4	4		
Actuator	Air sup. PSIG																				
ST6175.B6-7D Stroke 2 3/8" (60mm) Stem 1 1/4" Spring-range 23.2-68.2 psi Actuator Code: DLB_	60	Parabolic									674	431	168	111							
		On/Off, V port, Mixing										750	750	528	229	108	45	14			
		Diverting										750	750	528	349	146	69	32	8		
		Perforated										674	431	73							
	90	Parabolic										750	750	750	573	251	161	77			
		On/Off, V port, Mixing										750	750	750	690	403	235	145	44		
		Diverting										750	750	750	750	442	258	163	82	28	
		Perforated										750	750	750	393	251	112				
ST6175.C6-3D Stroke 4" (100mm) Stem 1 1/4" Spring-range 11.6-30.5 psi Actuator Code: DNB_	30	Parabolic									637	408	219	144	64	41	20				
		On/Off, V port, Mixing										750	520	308	174	102	59	37	11		
		Diverting										750	520	308	203	112	65	41	21	7	
		Perforated										637	408	196	99	64	28				
	60	Parabolic										750	750	750	606	359	230	151	75	42	29
		On/Off, V port, Mixing										750	750	750	636	398	248	168	85	48	29
		Diverting										750	750	750	665	407	254	172	95	54	33
		Perforated										750	750	750	561	359	218	134	66	42	29
	90	Parabolic										750	750	750	750	655	419	282	149	89	62
		On/Off, V port, Mixing										750	750	750	750	693	437	299	159	96	62
		Diverting										750	750	750	750	703	444	304	168	102	66
		Perforated										750	750	750	750	655	407	265	140	89	62
ST6175.C6-7D Stroke 4" (100mm) Stem 1 1/4" Spring-range 27.6-68.2 psi Actuator Code: DQB_	60	Parabolic									750	674	357	236	86	55	20				
		On/Off, V port, Mixing										750	750	546	296	168	56	11			
		Diverting										750	750	546	360	189	108	67	32	7	
		Perforated										750	674	301	134	86	28				
	90	Parabolic										750	750	750	697	381	244	151	64	28	19
		On/Off, V port, Mixing										750	750	750	750	464	286	188	85	41	19
		Diverting										750	750	750	750	485	297	198	106	54	29
		Perforated										750	750	750	596	381	218	114	44	28	19

*Valves with 1/2" Stem, Stroke 1 3/8"

Valves with 1 1/4" Stem, Stroke 2"

Note – Shutoff values for PTFE/Graphite packing. Consult factory for shutoff ratings when using other packing types.



REFlex Dimensions and Weights

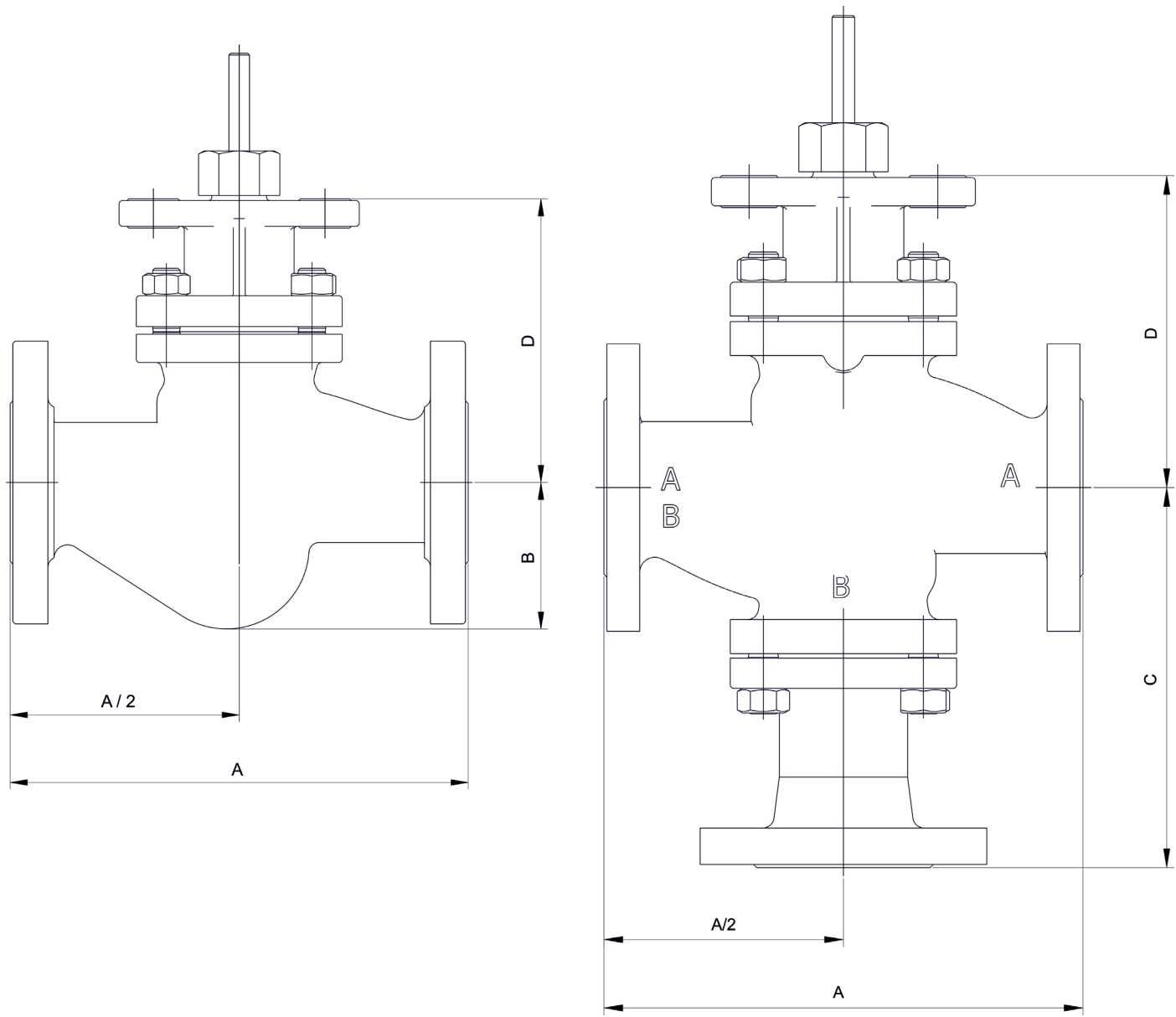

REflex Dimensions and Weights (continued)

Size	Class	Dimensions							Weight			
		A		B	C	D		2 way		3 Way		
		FLG	THD			½" Stem Dia	1¼" Stem Dia.	½" Stem Dia	1¼" Stem Dia.	½" Stem Dia.	1¼" Stem Dia.	
½	150	7¼ (184)	8½ (206)	1¾ (45)		5¾ (137)		11 (5)				
	300	7½ (190)	8½ (206)	1⅞ (47)		5¾ (137)		11 (5)				
	600	8 (203)		1⅞ (47)		7⅞ (194)		22 (10)				
¾	150	7¼ (184)	8¼ (210)	2 (50)		5¾ (137)		13 (6)				
	300	7⅝ (194)	8¼ (210)	2¼ (57)		5¾ (137)		13 (6)				
	600	8¼ (206)		2¼ (57)		7⅞ (194)		24 (11)				
1	150	7¼ (184)	8¼ (210)	2⅛ (54)	6⅞ (157)	5⅝ (142)		17 (8)		24 (11)		
	300	7¾ (197)	8¼ (210)	2½ (62)	6½ (164)	5⅝ (142)		22 (10)		31 (14)		
	600	8¼ (210)		2½ (62)		9 (227)		35 (16)				
	900	11 (279)		3 (75)		9 (227)		40 (18)				
1½	150	8¾ (222)	9⅞ (251)	2½ (63)	7½ (190)	6⅝ (169)		29 (13)		40 (18)		
	300	9¼ (235)	9⅞ (251)	3⅛ (78)	7⅞ (194)	6⅝ (169)		35 (16)		51 (23)		
	600	9⅞ (251)		3 (77)		10 (254)		55 (25)				
	900	13 (330)		3½ (90)		10 (254)		60 (27)				
2	150	10 (254)	11¼ (286)	3 (76)	7⅞ (201)	6½ (165)	8⅛ (206)	33 (15)	44 (20)	46 (21)		
	300	10½ (267)	11¼ (286)	3¼ (82)	8¼ (208)	6½ (165)	8⅛ (206)	38 (17)	49 (22)	60 (27)		
	600	11¼ (286)		3⅝ (92)		11 (278)	10½ (267)	88 (40)	104 (47)			
	900	14¾ (375)		4¼ (107)		11 (278)	10½ (267)	108 (49)	132 (60)			
2½	150	10⅞ (276)		3½ (89)	8¾ (222)	6¾ (171)	8¼ (211)	40 (18)	49 (22)	64 (29)		
	300	11½ (292)		3¾ (95)	9 (230)	6¾ (171)	8¼ (211)	44 (20)	53 (24)	82 (37)		
3	150	11¾ (298)		3¾ (95)	8⅞ (207)	7¾ (198)	8¾ (222)	64 (29)	86 (39)	110 (50)	119 (54)	
	300	12½ (318)		4⅞ (105)	8½ (216)	7¾ (198)	8¾ (222)	73 (33)	97 (44)	123 (56)	132 (60)	
	600	13¼ (337)		4⅞ (124)		13⅞ (334)	12⅝ (319)	150 (68)	176 (80)			
	900	18⅞ (460)		5 (127)		13⅞ (334)	12⅝ (319)	170 (77)	207 (94)			
4	150	13⅞ (353)		4½ (114)	10⅞ (258)	8⅞ (224)	9½ (242)	103 (46)	123 (56)	143 (65)	154 (70)	
	300	14½ (368)		5 (127)	10½ (266)	8⅞ (224)	9½ (242)	106 (48)	141 (64)	161 (73)	170 (77)	
	600	15½ (394)		5⅝ (137)		15⅞ (384)	14⅜ (365)	205 (93)	242 (110)			
	900	20⅞ (530)		5¾ (145)		15⅞ (384)	14⅜ (365)	256 (116)	302 (137)			
6	150	17¾ (451)		5½ (140)	12⅞ (308)	12½ (316)	12⅞ (328)	194 (88)	231 (105)	271 (123)	348 (158)	
	300	18⅝ (473)		6¼ (159)	12½ (319)	12½ (316)	12⅞ (328)	216 (98)	254 (115)	293 (133)	370 (168)	
8	150	21⅜ (543)		8 (200)	14¾ (374)		17 (431)		357 (162)		536 (243)	
	300	22⅝ (568)		8 (200)	15¼ (386)		17 (431)		397 (180)		586 (266)	
10	150	26½ (673)		10 (252)	17⅝ (446)		20⅞ (530)		569 (258)		772 (350)	
	300	27⅞ (708)		10 (252)	18⅞ (459)		20⅞ (530)		668 (294)		855 (388)	
12	150	29 (737)		13¼ (335)	22⅞ (562)		26 (660)		754 (342)		957 (434)	
	300	30½ (775)		13¼ (335)	22⅞ (562)		26 (660)		853 (387)		1056 (479)	

Dimensions in Inches (mm)

Weight in Lbs. (Kg)

Consult factory for dimensions of valves with Butt Weld Ends.



REflex Dimensions and Weights (continued)

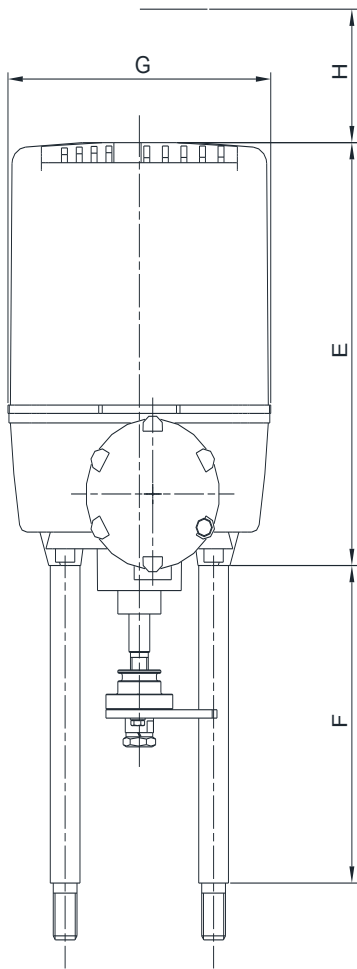

Electric Actuator

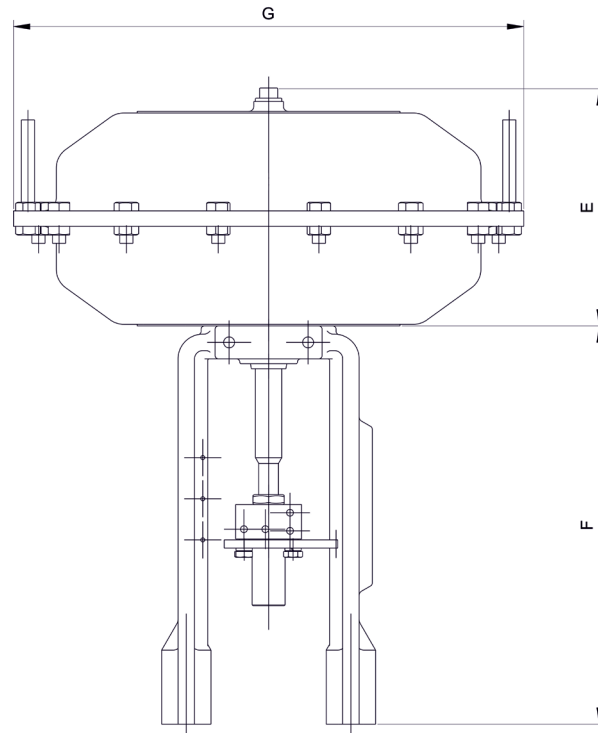

Pneumatic Actuator

Actuator	E		F		G		H		Weight	
Electric										
REact 15	7¼	(184)	7⅛	(180)	7⅜	(186)	5⅛	(130)	9	(4.2)
REact 30	9¼	(233)	7½	(190)	10⅜	(262)	4¾	(120)	10	(4.5)
REact 60	9¼	(233)	11⅝	(295)	10⅜	(262)	4¾	(120)	15	(6.7)
REact 100	9¼	(233)	11⅝	(295)	10⅜	(262)	4¾	(120)	15	(6.7)
ST5106	8⅞	(225)	16⅞	(430)	8⅛	(205)	7⅞	(200)	48.5	(22)
Pneumatic										
ST6135.B6	5⅜	(136)	8¼	(211)	8¼	(210)			16.5	(7.5)
ST6160.A6	6½	(166)	8¼	(211)	12¼	(310)			33	(15)
ST6160.C6	7⅜	(186)	9⅛	(231)	12¼	(310)			36.5	(16.5)
ST6175.B6	9¼	(234)	11¼	(285)	16⅞	(430)			105.5	(48)
ST6175.C6	14¾	(374)	12⅝	(320)	16⅞	(430)			147.5	(67)

*For actuators with standard pillars/yokes (Pillars and yokes same length)
Dimensions in Inches (mm) Weight in Lbs. (Kg)*

For length of pillars for valves with bellows seal, Fail safe unit, refrigeration valves and class 600# and 900# valves, please contact factory or authorized CIRCOR representative.



REflex Order Code

REflex Code Selection Example



Model	Position 1
R REflex	
Standard	Position 2
A ANSI	
Body Style	Position 3
A 2-way	
B 3-way	
D Feedwater recirculation	
E Bottom blow down	
F Continous blow down	
G Steam converting	
S Other	
Valve Size	Position 4
C ½"	
D ¾"	
E 1"	
G 1½"	
H 2"	
J 2½"	
K 3"	
L 4"	
N 6"	
P 8"	
Q 10"	
R 12"	
Valve Rating	Position 5
1 Class 150	
3 Class 300	
6 Class 600	
9 Class 900	
Body Material	Position 6
A A216 WCB	
B A351 CF8M	
C A217 WC9	
S Other	
End Connection	Position 7
A Flanges RF	
B Flanges with groove	
C Butt Weld Ends	
D NPT [½" – 2"]	
E Other	
Packing	Position 8
A PTFE/Graphite	
B PTFE white	
C Chloroprene	
D Graphite	
E Bellow seal	

Plug Type	Position 9
A On/Off	
B On/Off soft sealing	
C V-port (LIN)	
D V-port soft sealing (LIN)	
E Parabolic (LIN)	
F Parabolic (EQ%)	
G Parabolic soft sealing (LIN)	
H Parabolic soft sealing (EQ%)	
J Parabolic hardened (LIN)	
K Parabolic hardened (EQ%)	
L Perforated (LIN)	
M Perforated (EQ%)	
N Perforated soft sealing (LIN)	
P Perforated soft sealing (EQ%)	
Q Perforated hardened (LIN)	
R Perforated hardened (EQ%)	
T Ferro-Titanium (LIN)	
U Ferro-Titanium (EQ%)	
V Mixing (LIN/LIN)	
W Diverting (LIN/LIN)	
S Other	
Seat Type	Position 10
A Standard (metallic)	
B Stellite	
S Other	
Seat Size	Position 11
A ⅛"	
B ¼"	
C ⅜"	
D ½"	
E ¾"	
F 1"	
G 1¼"	
H 1½"	
J 2"	
K 2½"	
L 3"	
M 4"	
N 5"	
P 6"	
Q 8"	
R 10"	
T 12"	

Actuator Type	Position 12
A ST 6115	
B ST 6135	
C ST 6160	
D ST 6175	
E REact 30 (ST 5112)	
F REact 60 (ST 5113)	
G REact 100 (ST 5114)	
H ST 5106	
J ST 5116	
K REact 15 E	
N Manual	
S Other	
U None (stem ½", max. 2250 lbf)	
V None (stem 1¼", max. 13000 lbf)	
W None (stem 2⅜", max. 18000 lbf)	
Actuator Spring/ Voltage	Position 13
A 13-30 PSIG (A6-3S)	
B 12-35 PSIG (C6-4S)	
C 3-15 PSIG (B6-2G)	
D 12-44 PSIG (B6-6G)	
E 12-40 PSIG (A6-6G)	
F 4-20 PSIG (C6-3G)	
G 10-45 PSIG (C6-7G)	
H 4-13 PSIG (B6-2S)	
J 10-30 PSIG (B6-3D)	
K 17-20 PSIG (B6-5D)	
L 23-70 PSIG (B6-7D)	
M 7-20 PSIG (C6-3S)	
N 12-30 PSIG (C6-3D)	
P 20-50 PSIG (C6-5D)	
Q 28-70 PSIG (C6-7D)	
R 24 V DC	
T 24 VAC 1-ph	
U 115 V AC 1-ph	
V 230 V AC 1-ph	
W 400 V AC 3-ph	
S Other	
X None	

Working Direction / Actuating Speed	Position 14
A AFC Reverse	
B AFO Direct	
C AFC Reverse (w/Handwheel)	
D AFO Direct (w/Handwheel)	
E LLP	
F 0.47"/min REact 30/60/100	
G 0.71"/min REact 15/30/60/100/ST5106	
H 0.90"/min REact 15	
J 1.06"/min REact 30/60/100	
K 1.35"/min REact 15	
L 1.75"/min REact 30	
M 2.01"/min REact 30	
N 2.13"/min REact 60/100/ST5106	
P 2.65"/min REact 15/30	
Q 4.02"/min REact 60	
R 4.25"/min ST 5106	
<i>*Not available for 115V</i>	
S Other	
X None	
Accessories	Position 15
A PS2	
B PS2 w/ Feedback Module	
C PS2 HART	
D PS2 Profibus	
E Foxboro SRP 981 MM	
F PS2 + airfilter	
G PS2 with Feedback Module + airfilter	
H PS2 HART + airfilter	
J PS2 Profibus + airfilter	
K Foxboro SRP 981 MM + airfilter	
L EEx PS2	
M EEx PS2 with Feedback Module	
N EEx PS2 HART	
P EEx PS2 Profibus	
Q EEx PS2 + airfilter	
R EEx PS2 with Feedback Module + airfilter	
T EEx PS2 HART + airfilter	
U EEx PS2 Profibus + airfilter	
1 Feedback poti 1 kOhm	
2 OUT 4-20mA (REtrans)	
3 IN/OUT 4-20mA (REpos)	
4 Fail Safe Unit	
5 Fail Safe Unit & IN/OUT 4-20mA	
S Other	
X None	

PNEUMATIC

ELECTRIC

