



Central station or booster humidifiers in air handling systems

(physical data, dimensions and capacities)

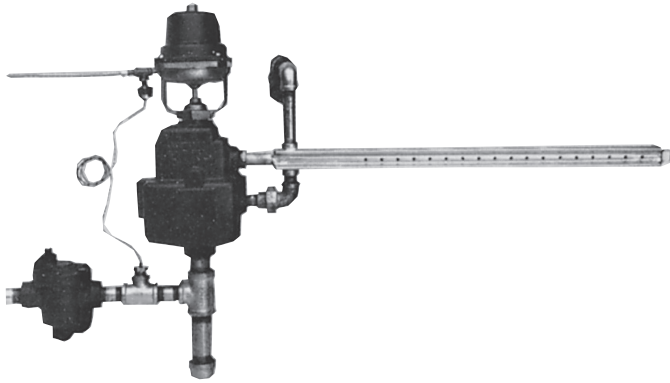

Figure 56-1.

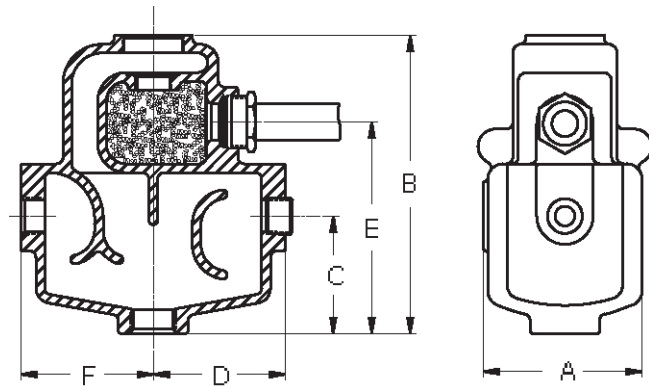

Table 56-1. Physical Data

Humidifier Model Number	Dimensions, Inches						Connection Sizes			Drain Trap Model	Weight, lbs. † (less operator and manifold)
	A	B*	C	D	E	F	Inlet	Drain	Trap		
**90	4	4-5/8	1-7/8	2-3/8	2-7/16	2-13/16	1/2" NPT	1" NPT	1/2" NPT	800	13-1/2
91	4-9/16	8-9/16	3-3/8	3-1/16	6-1/16	3-13/16	1/2" NPT	1" NPT	3/4" NPT	800	24
92	5-9/16	8-9/16	3-3/8	3-13/16	6-1/16	3-13/16	3/4" NPT	1" NPT	3/4" NPT	800	30
93	6-3/4	11-7/8	4-5/8	4-3/4	9	4-3/4	1-1/4" NPT	1-1/4" NPT	3/4" NPT	811	52
94	10-7/8	17-1/8	6-7/8	8	12-5/8	8	2" NPT	2" NPT	3/4" NPT	812	145

†Weight includes drain trap, strainer, and fittings. *Add height and weight of operator for overall data. See Table 56-1, Page 56.

**For more information, see Page 68.

For Physical Data on Series 1000 Stainless Steel Humidifiers, see Page 71.

Table 56-2. List of Materials

Steam Chamber	Cast Iron	Manifold Coupler	Brass
Bonnet Assembly	Brass	Nut	Brass
Valve & Stem	18-8 Stainless Steel	Strainer	Cast Iron
Valve Seat	18-8 Stainless Steel	Tubing (Model 90 Only)	Copper
Manifold	304 Stainless Steel	Compression Fittings (Model 90 Only)	Brass
Manifold Fittings	Brass	Steam Trap	Cast Iron

Designs, materials, weights and performance ratings are approximate and subject to change without notice. Visit armstronginternational.com for up-to-date information.

Armstrong Conditioned-Steam Humidifiers for air handling systems are manufactured to meet the needs of central station humidification or booster humidification. Operation and control may be pneumatic or electric. (See Page 54.)

Standard Package

All Armstrong Conditioned-Steam Humidifiers are supplied in standard “packages” which include the following:

Pneumatically Controlled (AM) Models:

1. Humidifier with integral operator.
2. Distribution manifold of length specified.
3. “Y” type strainer.
4. Armstrong inverted bucket trap.

Electric Motor Controlled (EM) Models:

1. Humidifier with integral operator.
2. Distribution manifold specified.
3. “Y” type strainer.
4. Armstrong inverted bucket trap.

Recommended Option

A pneumatic or an electric temperature switch is offered as an optional extra and is recommended in any system where the steam supply to the manifold jacket and humidifier body may be interrupted or turned off.

Table 57-1. Sizes 90, 91 and 1100, Continuous Discharge Capacities in lbs. of Steam Per Hour

Orifice Size (In)	Steam Pressure, psig																						
	2	3	4	5	6	7	8	9	10	11	12	13	14	15	20	25	30	35	40	45	50	55	60
1/16	1.3	1.7	2.0	2.3	2.6	2.8	3.0	3.2	3.4	3.6	3.8	4.0	4.2	4.4	5.6	6.5	7.7	8.4	9.2	10.0	11.0	11.8	12.3
5/64	2.1	2.7	3.2	3.7	4.1	4.4	4.8	5.1	5.4	5.7	6.0	6.2	6.4	6.7	8.4	10.6	11.2	12.4	13.0	14.8	16.0	17.8	19.0
3/32	3.0	3.9	4.6	5.2	5.8	6.3	6.8	7.3	7.8	8.2	8.6	9.0	9.3	9.6	11.9	13.4	14.3	17.2	19.2	21.2	22.8	23.7	24.4
7/64	4	5	6	7	8	8	9	10	10	11	11	12	12	13	16	18	19	21	24	26	28	31	33
1/8	5	7	8	9	10	11	12	13	14	14	15	16	17	18	23	25	28	30	33	35	37	40	44
5/32	8	10	12	14	16	17	19	20	21	22	23	25	26	27	31	36	40	44	48	52	56	60	65
3/16	12	15	18	21	23	26	27	29	31	32	35	36	37	40	47	52	59	65	70	77	83	88	93
7/32	16	21	25	29	32	35	37	40	42	44	47	49	51	53	62	70	84	90	98	103	113	126	135
1/4	22	28	33	38	42	46	49	53	55	59	62	64	67	69	82	91	102	115	125	135	150	160	170
9/32	26	32	38	43	47	50	54	58	61	64	67	70	72	75	89	102	115	125	140	150	160	175	185
5/16	32	38	44	50	55	60	64	68	73	77	82	85	88	92	105	123	134	148	167	198	216	234	251
11/32	36	43	50	55	66	72	76	81	85	90	94	97	103	108	127	147	172	190	209	230	248	267	277
3/8	42	50	56	65	70	76	82	93	97	105	110	115	121	126	150	171	191	212	233	255	272	303	316

Note: Capacities below darkened line pertain to models 91 and 1100 only. Also see Table 68-1, Page 68, for size 90 capacities.

Table 57-2. Sizes 92 and 1200, Continuous Discharge Capacities in lbs. of Steam Per Hour

Orifice Size (In)	Steam Pressure, psig																						
	2	3	4	5	6	7	8	9	10	11	12	13	14	15	20	25	30	35	40	45	50	55	60
1/8	5	7	8	9	10	11	12	13	15	16	17	18	19	20	23	25	28	31	33	36	38	41	44
5/32	8	10	12	14	16	17	19	20	21	22	23	25	26	27	31	36	40	44	48	52	56	60	65
3/16	12	15	18	21	23	26	27	29	31	32	35	36	37	40	47	52	59	65	70	77	83	88	93
7/32	16	21	25	29	32	35	37	40	42	44	47	49	51	53	62	70	84	90	98	103	113	126	135
1/4	22	28	33	38	42	46	49	53	55	59	62	64	67	69	82	91	102	115	125	135	150	160	170
9/32	27	35	42	48	53	58	63	67	71	75	79	81	85	88	103	117	129	140	159	177	190	199	213
5/16	33	43	51	59	65	71	77	82	87	92	97	100	104	108	127	144	159	172	197	212	228	243	261
11/32	40	52	62	70	78	84	91	97	102	109	114	119	124	129	152	172	192	206	236	252	270	297	313
3/8	53	59	65	78	84	92	99	104	115	119	123	128	133	138	162	183	205	226	246	269	290	314	334
7/16	74	84	90	99	108	117	123	131	136	143	150	158	164	170	197	224	250	277	316	346	370	400	423
1/2	88	95	100	105	112	121	133	142	150	159	166	173	182	194	230	268	300	334	367	399	428	462	486



Humidifiers in air handling systems, continued...

(physical data, dimensions and capacities)

Table 58-1. Sizes 93 and 1300, Continuous Discharge Capacities in lbs. of Steam Per Hour

Capacities when Steam Supply is Through the Manifold. See Figure 57-1, Page 57.																							
Orifice Size (In)	Steam Pressure, psig																						
	2	3	4	5	6	7	8	9	10	11	12	13	14	15	20	25	30	35	40	45	50	55	60
13/32	70	84	100	110	121	132	139	148	153	160	169	173	180	185	212	246	270	297	330	356	384	413	441
7/16	77	95	108	125	129	138	146	155	169	176	189	196	204	213	246	286	312	336	363	401	432	464	497
15/32	83	122	130	145	150	157	167	180	193	202	211	225	230	238	282	319	356	385	416	447	480	517	546
1/2	99	128	145	160	172	185	198	202	217	228	242	253	264	272	321	364	407	435	460	500	540	581	621
9/16	103	137	159	185	196	208	225	238	258	266	271	283	291	310	360	408	456	515	562	614	661	719	753
5/8	117	147	175	202	213	234	252	274	289	296	317	338	347	369	428	488	547	607	664	726	785	847	900
3/4	127	174	203	232	255	287	300	338	361	374	382	409	436	459	548	637	745	848	924	996	1082	1179	1270

Table 58-2. Sizes 93 and 1300, Continuous Discharge Capacities in lbs. of Steam Per Hour

Capacities when Steam Supply is Direct to Separator. (Manifold Trapped Separately). See Figure 59-2, Page 59.																							
Orifice Size (In)	Steam Pressure, psig																						
	2	3	4	5	6	7	8	9	10	11	12	13	14	15	20	25	30	35	40	45	50	55	60
13/32	70	84	100	110	121	132	139	148	153	160	169	173	180	185	212	246	270	297	330	356	384	413	441
7/16	77	95	108	125	129	138	146	155	169	176	189	196	204	213	246	286	312	336	363	401	432	464	497
15/32	83	122	130	145	150	157	167	180	193	202	211	225	230	238	282	319	356	385	416	447	480	517	546
1/2	99	128	145	160	172	185	198	202	217	228	242	253	264	272	321	364	407	435	460	500	540	581	621
9/16	103	137	159	185	196	208	225	238	258	266	271	283	291	310	360	408	456	515	562	614	661	719	753
5/8	125	160	183	209	225	248	263	285	307	314	336	358	372	381	460	512	575	641	696	757	831	924	977
3/4	136	187	220	263	270	300	336	376	409	430	464	495	510	524	635	740	827	931	1017	1103	1195	1281	1366

Table 58-3. Sizes 94 and 1400, Continuous Discharge Capacities in lbs. of Steam Per Hour

Capacities when Steam Supply is Through the Manifold. See Figure 59-1, Page 59.																			
Orifice Size (In)	Steam Pressure, psig																		
	2	3	4	5	6	7	8	9	10	11	12	13	14	15	20	25	30		
5/8	137	167	190	213	225	251	266	289	312	327	350	372	388	414	478	541	606		
3/4	185	227	258	290	309	340	361	391	425	443	474	505	525	556	684	772	859		
7/8	243	297	338	378	405	446	473	513	553	581	621	662	689	758	873	996	1109		
1	278	343	390	437	468	515	546	593	639	671	718	764	796	850	991	1134	1268		
1-1/8	320	396	450	508	540	594	630	684	748	774	828	882	918	931	1117	1304	1469		
1-1/4	344	418	475	553	570	627	665	722	795	817	874	931	969	988	1182	1391	1567		
1-1/2	390	490	558	621	669	736	781	847	919	959	1026	1093	1137	1153	1396	1607	1816		

Table 58-4. Sizes 94 and 1400, Continuous Discharge Capacities in lbs. of Steam Per Hour

Capacities when Steam Supply is Direct to Separator. (Manifold Trapped Separately). See Figure 59-2, 59-3, Page 59.																							
Orifice Size (In)	Steam Pressure, psig																						
	2	3	4	5	6	7	8	9	10	11	12	13	14	15	20	25	30	35	40	45	50	55	60
5/8	137	167	190	213	225	251	266	289	312	327	350	372	388	414	478	541	606	668	733	798	881	954	1017
3/4	198	242	275	308	330	363	385	418	451	473	506	539	561	607	707	790	890	982	1073	1175	1264	1357	1446
7/8	252	308	350	392	420	462	490	532	574	602	644	686	714	790	908	1017	1147	1270	1399	1537	1650	1781	1867
1	299	374	425	489	510	561	595	646	718	731	782	833	867	938	1075	1233	1393	1528	1688	1835	1978	2118	2289
1-1/8	370	462	525	588	630	693	735	798	834	903	966	1029	1071	1114	1334	1539	1695	1895	2105	2262	2468	2644	2822
1-1/4	413	517	588	661	705	776	823	893	960	1011	1081	1152	1199	1214	1487	1729	1946	2158	2386	2607	2800	3053	3205
1-1/2	540	660	750	840	900	990	1050	1140	1206	1290	1380	1470	1530	1541	1858	2118	2416	2648	2925	3193	3600	3870	4020

Note: Steam Pressure used to jacket 94 size manifold must not exceed 30 psig. Steam pressure can go to 60 psig if multiple 93 size manifolds are used. (See Figure 59-3, Page 59).

Metric Conversion: lb/hr x .4536 = kg/hr; psig x 6.89 = kPa

Note: Please consult Armstrong for choice of pneumatic actuator on 94 size humidifier when steam pressure is above 30 psig.

Steam Supply Methods

Figure 59-1. Steam supply through manifold

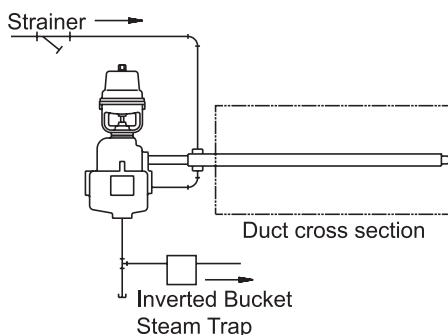

Figure 59-2. Steam supply direct to separator (Manifold trapped separately)

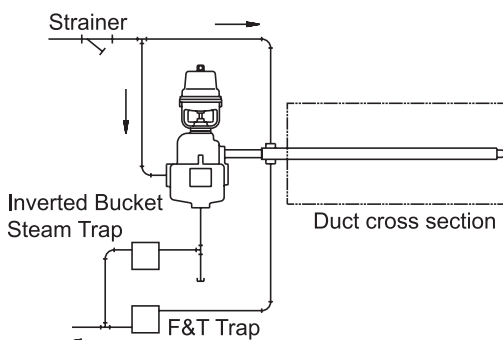
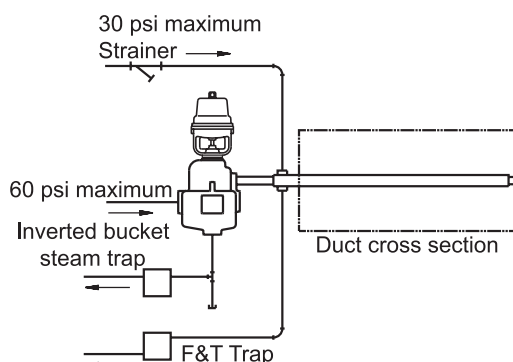

Figure 59-3. Steam supply direct to separator (Manifold trapped separately)



*30 psi maximum for size 94 and 1400 manifolds.

How to Order

1. Mode of control pneumatic modulating – AM, electric modulating – EM

For industrial in-plant operation and for certain very limited duct applications, a solenoid actuator may be used to provide simple on-off operation. This type of actuator should not be specified for duct applications without a detailed analysis of the system – DSA.

2. Size of humidifier for duct installation – 90, 91, 92, 93, 94
3. Manifold length from Table 61-2, Page 61.
4. Specify steam pressure and capacity required in accordance with Tables on Pages 57 and 58.
5. For electrically operated models, state electrical characteristics (control signal, and power supply voltage).

Suggested Specification

Steam Humidifiers for pneumatic or electric modulating control: Humidifier shall be the steam separator type providing full separation ahead of an integral steam jacketed control valve which discharges through an internal steam jacketed drying chamber, a silencing chamber and a steam jacketed distribution manifold.

- A. Humidifier shall receive steam at supply pressure and discharge at atmospheric pressure. It shall be furnished with inlet strainer and external inverted bucket steam trap.
- B. Separating chamber shall be of a volume and design that will disengage and remove all water droplets and all particulate matter larger than 3 microns when humidifier is operating at maximum capacity.
- C. The stainless steel metering valve shall be integral within the body of the humidifier, and shall be jacketed by steam at supply pressure and temperature to prevent condensation.
- D. The stainless steel metering valve shall be a parabolic plug with a 3¼" stroke, providing the high rangeabilities required to achieve full and accurate modulation of steam flow over the entire stroke of the valve.
- E. The internal drying chamber shall receive steam at essentially atmospheric pressure and be jacketed by steam at supply pressure and utilize a stainless steel silencing medium.
- F. The distribution manifold shall provide uniform distribution over its entire length and be jacketed by steam to assure that vapor discharged is free of water droplets.
- G. Humidifier shall be equipped with an interlocked temperature switch to prevent the humidifier from operating before start-up condensate is drained.