

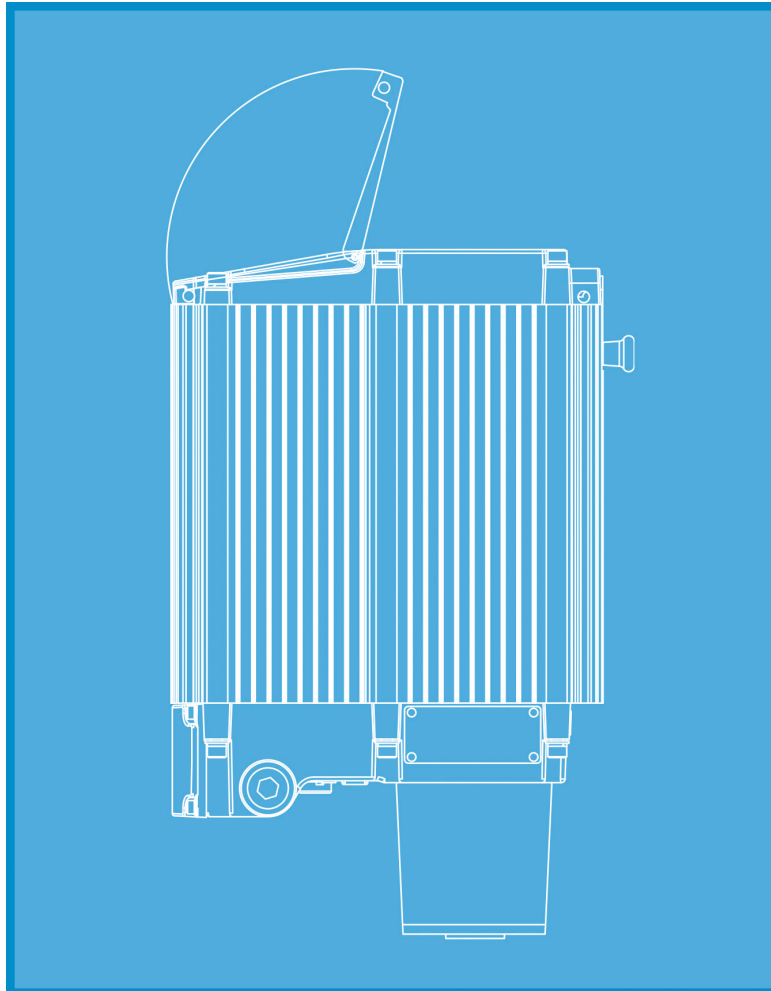

Digital Actuator - Model G1



Section / Description	Page
INTRODUCTION	4
1.0 ELECTRONIC ACTUATOR - MODEL G1 - DATASHEET	5
Parts and Materials.....	6
Dimensions.....	7
Technical Data	8, 9
Performance.....	10
2.0 MECHANICAL INSTALLATION	11
2.1 Assembly of G1 onto Emech F3 and F5 Valves	11
2.2 Assembly of G1 onto Other Valves.....	12
3.0 ELECTRICAL INSTALLATION	13
3.1 General information.....	13
3.2 Wiring Instructions.....	14
3.2.1 Power Supply Wiring	14
3.2.2 Power Supply Wire Specification.....	15
3.2.3 Wiring of Actuator mA Loop Receiver.....	15
3.2.4 Wiring of Actuator mA Loop Transmitter.....	16, 17
3.2.5 Temperature Sensor Connector (Port-1	18
3.2.6 Auxiliary Input (Port-2	18, 19
3.2.7 Serial Port Connector (Port-3	20
4.0 CURRENT LOOP I/O	21
4.1 Standard Configuration of Current Loop Input for Temperature Controller Mode.....	21, 22
4.2 Standard Configuration of Current Loop Input for Positioner Mode	23, 24
4.3 Standard G1 Current Loop Output Characteristic	25, 26

Section / Description	Page
5.0 EMECHCONFIG CONFIGURATION SOFTWARE	27
5.1 Installation	27
5.2 Operation.....	27
5.2.1 Getting Started	27
5.2.2 General Use	28
5.2.3 Changing Values	29
5.3 Property Categories.....	30
5.3.1 Temperature Controller Values	30
5.3.2 Motion Control Values	30
5.3.3 Auxiliary Controller Values.....	31
5.3.4 Selecting Standard Configuration Sets.....	32
6.0 KEYPAD OPERATING INSTRUCTIONS	33
6.1 'Dual Press' Fail Safe Button Operation	33
6.2 Controller Type Selection	33
6.3 Controller Units Selection	34
6.4 Remote & Local Control Toggle.....	34
6.5 Changing Values (Set Point)	35
6.6 Error Codes	35
6.7 Standard Operation Temperature Control	36
7.0 TROUBLESHOOTING	37
7.1 Troubleshooting Guide	38, 39, 40, 41
LEGAL DISCLAIMER	42

Introduction

Congratulations on selecting the Emech™ product from Armstrong. Armstrong devotes considerable care and attention to the design of its products. To obtain the best performance from them, the customer should read this manual from cover to cover. It contains important installation and operating instructions.

The customer must strictly adhere to the safety tips, troubleshooting advice, cautions and warnings appearing throughout this manual. Along with the warnings, instructions and procedures in this manual, the customer should also observe such other procedures generally applicable to equipment of the same type.

If the customer does not follow these and other such warnings, instructions and procedures, the product may not perform as expected. More seriously, it may cause property damage, personal injury, production down-time and other losses.

The customer should train its employees and contractors in the safe use of Armstrong products in relation to the customer's specific application. If the customer does not understand a point in this manual, contact Armstrong or its authorised representative.

G1 Actuator General Features

Emech G1 actuators offer all the benefits of intelligent control. High performance Closed loop temperature control is achieved when combined with Emech 3 and 2 port disc valves and sensors. Control with butterfly and other quarter turn valves can be significantly enhanced by the Emech actuator.

Multiple sensor connectivity options, and onboard software for stand alone closed loop control are included as standard features. Emech G1 actuators provide compact configurable high-speed actuation solutions for 0° and 350° applications, and torques up to 885 in.lb continuous.

Two sizes:

G12 model 310 in.lb torque: 24vDC 3.5 Amp

G13 model 885 in.lb torque: 24vDC 5 Amp

Electronic Features

- Analog (4-20mA input and output ports)
- Electrical stepper motor control
- Speed, position, and acceleration control
- User defined '2-speed' stroke can eliminate water hammer
- Precise positioning achieving 0.03° valve seat placement
- Local closed loop control of temperature
- External RS232 connection (cable supplied) communication for special mode configuration.
- Local/remote control options
- Two operating modes: Stand alone control via onboard keypad or Remote control via external 4-20mA
- Failsafe position feedback (non-contact absolute encoder)
- Keypad: 4 membrane switches with 'dual touch' safety features
- Display: 3.5 digit LCD display with back light
- Push button power switch providing soft start electronic control

Mechanical Features

- 90° stroke time as low as 1.5 seconds
- High speed 1.3 second quarter-turn response
- Roller bearing shaft support
- Gearbox: planetary, lifetime lubrication, low backlash
- Graduated visual indicator
- Epoxy powder coated aluminum enclosure
- Enclosure designed to Nema 4
- Manual over-ride with electrical safety interlock
- Stainless steel fasteners
- 100% Duty Cycle rated for continuous control
- Lockable display & keypad cover
- Magnetic latch on keypad cover
- Electronic stroke setting (up to 350° rotation)

Applications

- Emech F3 temperature control valves
- Emech F2 and other 1/4 turn control valves
- Heat exchanger control
- High speed electronic actuation
- Dairy: Pasteurizing
- Tanning: Pelt washing - temperature control
- Brewery: Mash water temperature control
- Meatworks: Hand wash/sterilization/washdown/tripewash
- Vessel Temperature Control
- CIP Skids
- Food, Beverage, Bakeries and General Industrial Process Control Applications



◀ Emech temperature control solution

F3 mixing valve and G1 actuator with integrated temperature sensor

Model Code: ExxW series

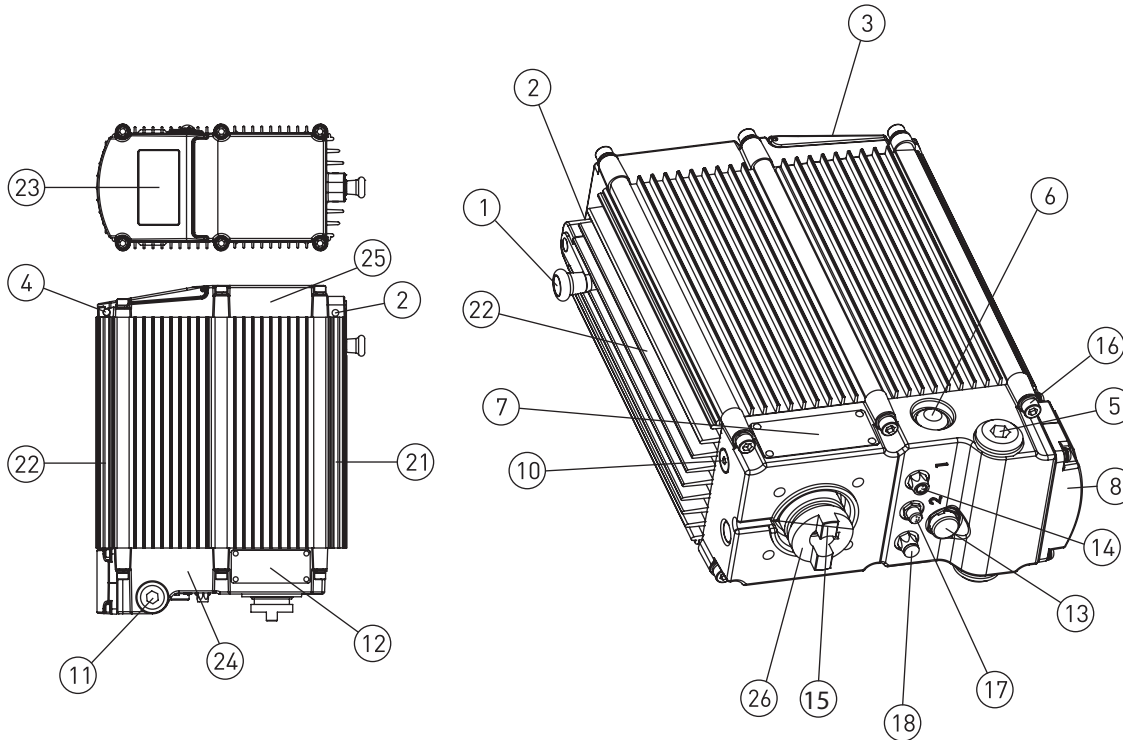
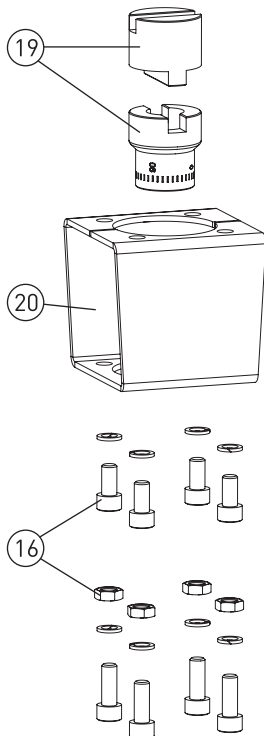

◀ G1 Electronic actuator mounted on a 2-port valve

Standard mounting kits
 (must be ordered separately)

G12 and G13 details

- 1 Manual override lever
- 2 Padlock holes for manual override
- 3 Keypad lid (in closed position)
- 4 Padlock holes for keypad lid
- 5 Cable entry (o-ring sealed 1" NPT plug, LHS)
- 6 Push button power switch
- 7 Warning label
- 8 Terminal cover, sealed, wiring access
- 10 Sealed plug (for factory encoder adjustment)
- 11 Cable entry (o-ring sealed 1/2" NPT plug, RHS)
- 12 Name plate
- 13 Pressure relief vent
- 14 Port-1, temperature sensor input
- 15 Drive shaft
- 16 Fixings and spring washers
- 17 Port-2, Auxiliary port
- 18 Port-3, Serial port
- 19 Coupling 2 piece slotted
- 20 Mounting bracket (Fits ISO5211 F05 & F07 size)
- 21 Drive enclosure (extrusion)
- 22 Electronics enclosure (extrusion)
- 23 Keypad cover window
- 24 Body base
- 25 Body top
- 26 Coupling fitting

Construction materials

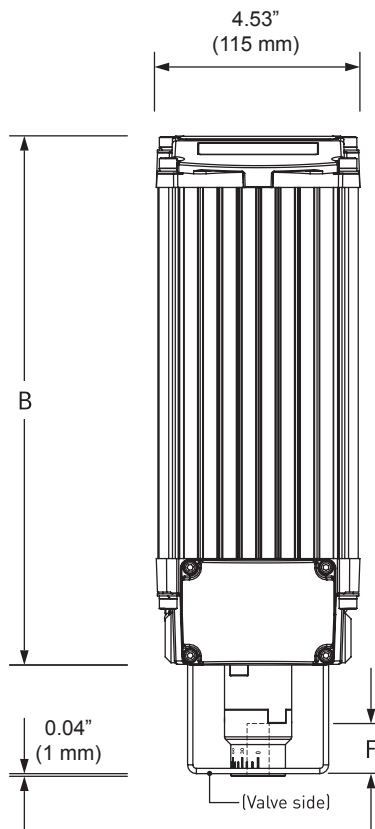
- 316 SS / acetal
- N/A
- Powder coated aluminum
- N/A
- Glass filled nylon
- Plastic with silicone cover
- 316 stainless steel
- Powder coated aluminum
- Nickel plated brass
- Glass filled nylon
- 316 stainless steel
- Polyamide 6
- Nickel plated brass
- 17-4 PH stainless steel
- Stainless steel
- Nickel plated brass
- Nickel plated brass
- Nickel plated brass
- 316 stainless steel
- 316 stainless steel
- Powder coated aluminum
- Powder coated aluminum
- Polycarbonate
- Powder coated aluminum
- Powder coated aluminum
- 316 stainless steel



Mounting Bracket Detail
(valve side shown)

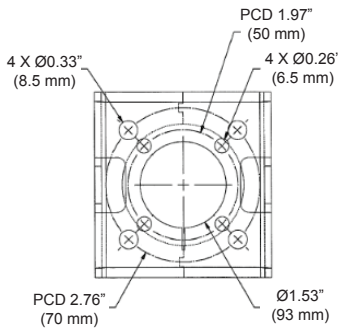

Mechanical Data

Height A
Height B
Weight
Rotation C Ø

F : Maximum shaft depth
G : Coupling (ID) square

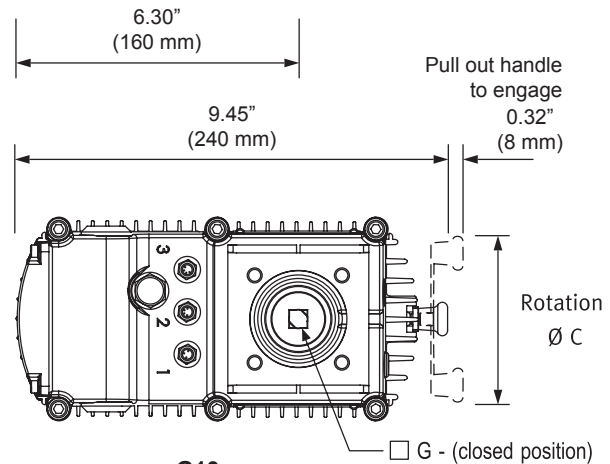
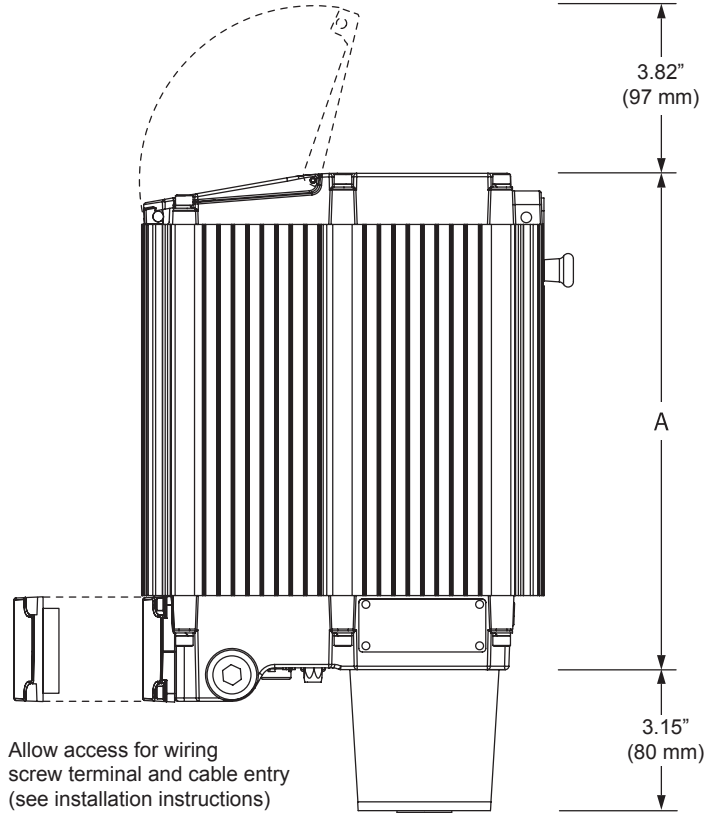

G12

11.02" (280 mm)
11.81" (300 mm)
18 lb (8 kg)
3.54" (90 mm)

G13

13.31" (338 mm)
14.09" (358 mm)
27 lb (11.5 kg)
7.09" (180 mm)

ISO F05 (CPMA0071)

1.12" (28.5 mm)
0.4" x 0.4" (10 mm x 10 mm)

ISO F07 (CPMA0070)

1.12" (28.5 mm)
0.55" x 0.55" (14 mm x 14 mm)

Note: Actuator side of mounting kits are all F07. Other mounting kits are available on request.

Environmental / Standards

Ambient Temperature	14°F (-10°C) to 122°F (+50°C)
Protection Standard (upright mounted)	Designed to meet NEMA 4
Protection Safety	C-Tick and CE, AS/NZ2064 Class A, EN 50081-1, EN50082-1 EN50082-2, FCC47 part-15 A7B
Mechanical Mounting	ISO 5210 / ISO 5211
EMC requirements	Actuator Housing and Cable Conduit must be connected to Earth

Device Mode / Specifications
Temperature Controller

Control Range	32°F (0.0°C) to 212°F (100.00°C)
Accuracy	± 0.9°F (0.5°C)
Setpoint Resolution	Local Mode ± 1.0°F (0.5°C) Remote Mode ± 0.18°F (0.1°C)

Positioner

Control Range	0 to 100 %
Stroke Range (user selectable)	0 to 350°
Accuracy	± 1°
Control Resolution	± 0.03°
Setpoint Resolution	Local Mode ± 0.5% Remote Mode ± 0.1%
Visual Shaft Position Indicator	10° Graduated Scale (on shaft coupling)

Torque / Speed ⁽¹⁾

	G12	G13
Nominal Torque	310 in.lb (35 Nm) @ 6 rpm	885 in.lb (100 Nm) @ 5 rpm
Default Maximum Speed	12 rpm	6 rpm
Default Speed	6 rpm	3 rpm
Nominal Stroke Time 1/3 Turn	1.5 seconds*	3.0 seconds*

* No slow zone and at maximum speed, acceleration and deceleration.

Manual Override

	G12	G13
Turns / 360 degree Shaft Revolution	74	124
Maximum Lever Force	3.0 lbf (1.5 kgf)	2.0 lbf (1.0 kgf)
Rotational Lever	Pull to engage Manual Override	

Operating Modes

Software Configurable Options	Local / Remote, Temperature Controller/Positioner Speed, Torque, Acceleration, Deceleration, Proportional and Differential control settings. (set via Serial Port and Configuration software)
Set Point Signal**	4-20mA Current loop input Remote, or Locally by keypad entry
Output Signal**	4-20mA Current loop output
**The Emech G1 current loop transmitter and receiver are both isolated.	
Keypad (local control)	4 membrane switches; Set, Up, Down and Mode (dual touch safely feature - 2 switches must be pressed simultaneously)





THE G1 MUST NOT BE INSTALLED UPSIDE DOWN

Electrical Data

Power Supply Requirement	24 Vdc	Regulated Supply ± 10% (at the actuator terminals)
Fuse	5.0 A	Mini Blade (see below for Part Number)
Control Signal (input)	4 to 20mA	
Feedback Signal (output)	4 to 20mA	Feedback Accuracy 0.5% (of full range)
Display (Set & Actual Value)	3.5 digit	7 segment LCD and back light
Indicators	4 LEDs	to indicate control mode and units
Serial Interface	RS232 (non-isolated), 4pin M8 (female) connector	
Auxiliary Sensor Input	4 pin M8 (male) connector	
Supply and Signal Connections	9 pole screw terminal in sealed compartment	
Temperature Sensor Input	3 pin M8 (female) connector	
Temperature Sensor	Thermistor (NTC 10kOhm @ 25°C)	
Cable Gland Entry	1/2" NPT (side entry, 1 on each side)	

Power Supply Consumption (at 24.0 Vdc)	Motor Current	Supply	Supply
	Software Setting * Current	Power	
	Model		
	G12	@I _{motor} =3A	3.4 A _{max} 85 Watt
	G13	@I _{motor} =4A	4.4 A _{max} 115 Watt

* Exceeding motor current and speed defaults will increase current and power

Electronic Actuator Model Code

Model	Nominal Torque ⁽¹⁾	Maximum Speed (RPM) ⁽¹⁾	Supply Voltage
G12	035 - 35 Nm / 310 in.lb @ 6 rpm	12	24D - 24VDC
G13	100 - 100 Nm / 885 in.lb @ 5 rpm	8	24D - 24VDC

Standard Models Available **G12**
G13

Accessory Parts

	Part Number
Operating / Installation Manual ⁽²⁾	CPAC0002
Actuator Configuration CD ⁽²⁾	CPAC0001
Serial Cable ⁽²⁾	CPEL0091
Temperature Probes (cable length)	CPAC0021 (350 mm) Longer cable length Temperature Probes available . Consult Armstrong
Mounting Kit F05 used on 3/4" (20 mm) and 1" (25 mm) Emech valves	CPMA0070
Mounting Kit F07 used on 1-1/2" (40 mm) , 2" (50 mm), and 3" (75 mm) Emech valves	CPMA0071
G13 Power Supply	D34095 (24vDC 5A for G13 actuator)
G12 Power Supply	D34094 (24vDC 3.5A for G12 actuator)
Mini Blade Fuse 5 A	MEFU0006

- Notes: (1) Nominal Torque is the output torque at 6 rpm for G12 and 5 rpm for G13.
Maximum Speed is the maximum recommended operating speed.
See G1 Torque Speed Performance data for details (page 6).
(2) These components are supplied with every actuator.

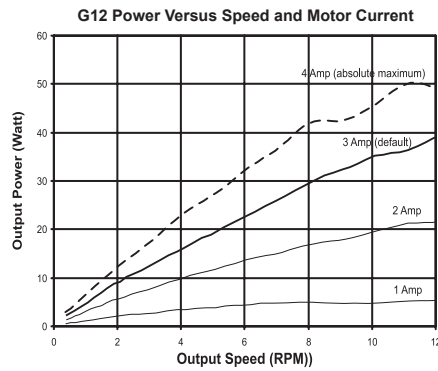
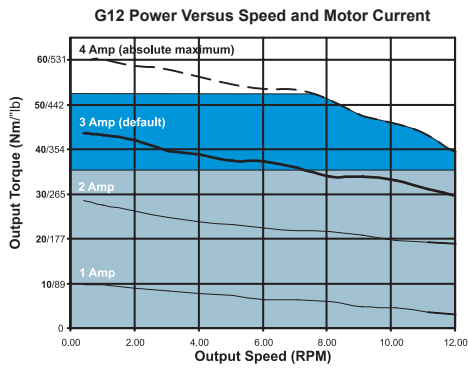
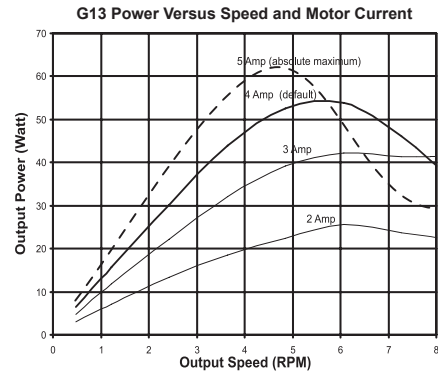
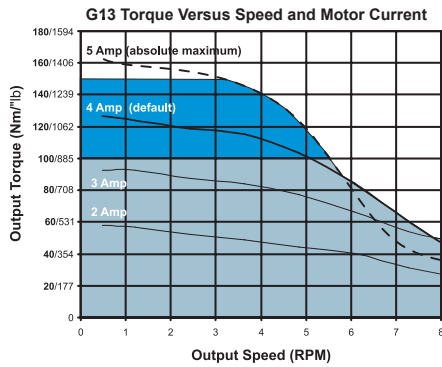

100% Duty Capable
 Maximum 5% Duty Without Impacting Gearbox Life

- Notes:**
- ⋮ The torques are at steady state speeds.
 - ⋮ No allowance has been made for load inertia. For high inertia loads contact Armstrong.
 - ⋮ Maximum allowable accelerations and decelerations are load dependent.
 - ⋮ Use the configuration software supplied with the G1 actuators to set the actuator torque, speed, and accelerations.
 - ⋮ These are typical characteristic curves. For individually certified actuator performance curves contact Armstrong.
 - ⋮ The user must ensure the duty cycles and maximum torque values are not exceeded.

Motion Profile Curve

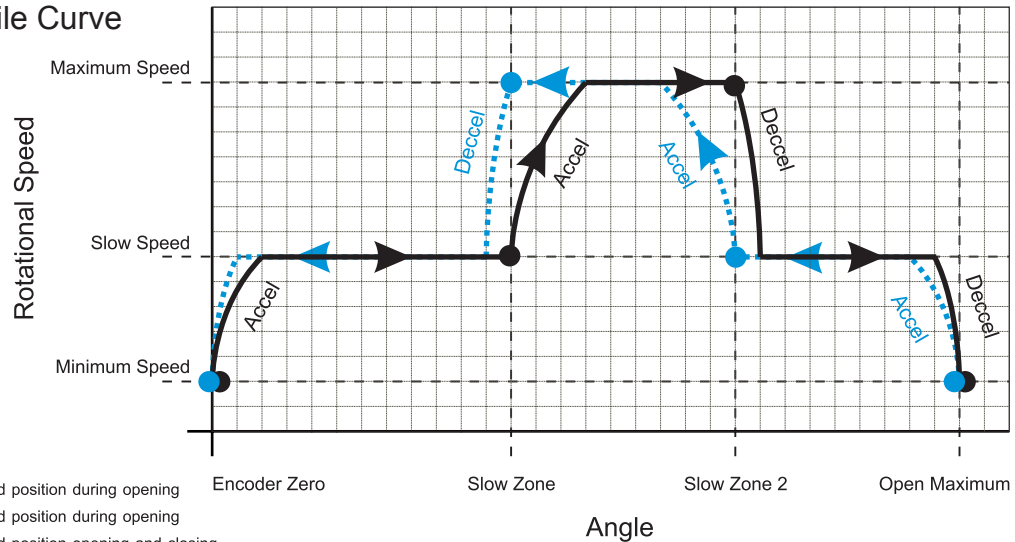



Note: The actuator may be mounted in any one of four positions.

The instructions below explain how to mount the actuator facing the outlet port as per image on page 7.

To ensure the actuator is in the 'zero' position, power on the actuator (a 24V DC regulated power supply is required). Ensure the actuator is in Temperature Controller mode - hold mode and press down (-) on the actuator keypad to toggle between Temperature and Positioner mode.

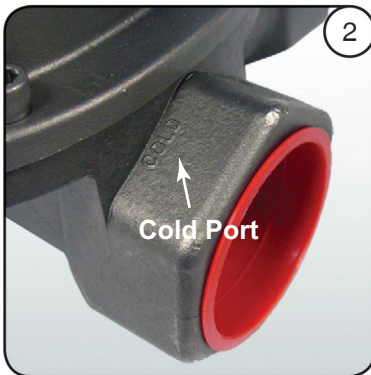
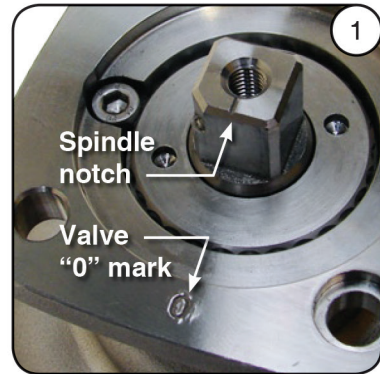

Once in temperature mode, disconnect the temperature probe from the actuator. The actuator will move automatically to the 'zero' position and the keypad display will show "E2".

Set the Valve position to closed. Ensure the notch on the spindle (image 1) points towards the valve "0" mark and the cold port (image 2) which is the fully closed position for the valve seats and the default cold port (image 2).

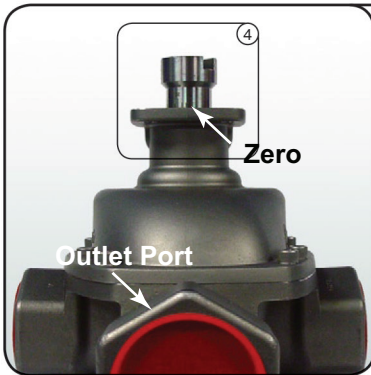

Place the graduated coupling (image 3) on the spindle & ensure the zero points to the outlet port (image 4).

If the actuator is to be mounted in one of the other three positions, rotate the graduated coupling so that the "ZERO" mark will line up with the notch in the bracket (image 8) of the actuator, when valve is fully coupled to actuator.

DO THIS ALIGNMENT BEFORE PLACING THE COUPLING ON THE SPINDLE.

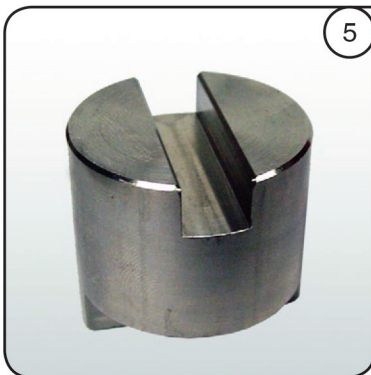
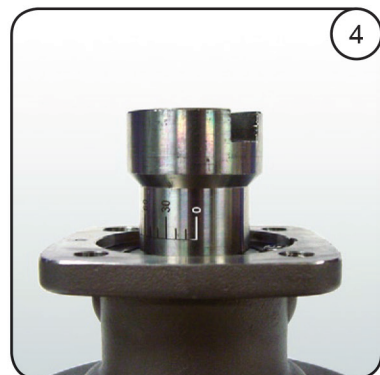

Place the center coupling (image 5) on the graduated coupling (image 6).

Continued...

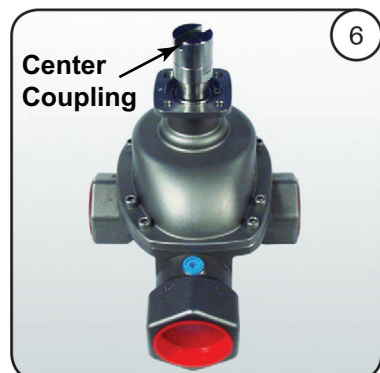

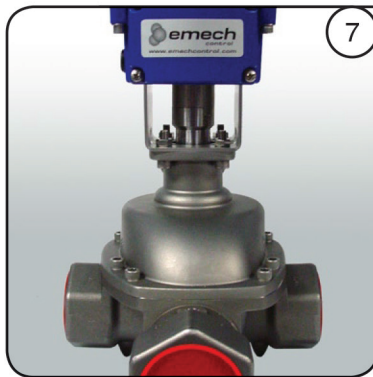

7 Place the actuator on the valve in the desired position (image 7). The zero mark on the coupling (image 4) should align with the notch on the bracket (image B).

Insert one M8 X 25 socket cap screw into one of the mounting holes with M8 Spring Washer and Nut. Insert the remaining three cap screws and fasten.

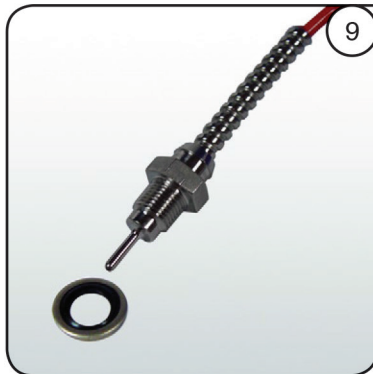
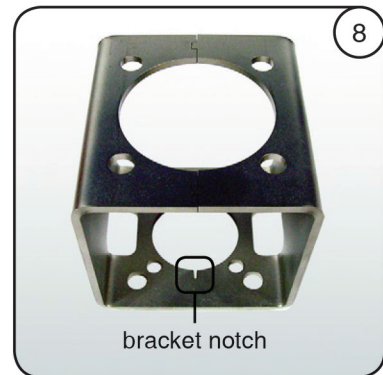

9 Ensure the bonded washer (image 0) is on the sensor (image 10).

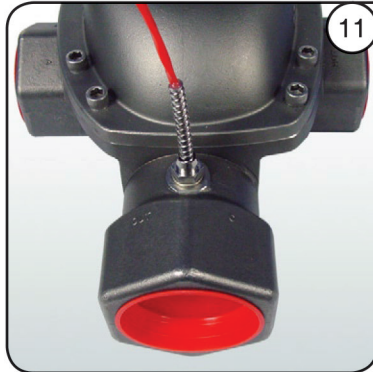

11 Screw the sensor into the outlet port of the valve (image 11) and tighten before connecting the the sensor to the actuator.

Plug the sensor connector into the actuator input port labelled "1" and hand tighten . The actuator is now assembled correctly (image 12).

WARNING!! DO NOT USE A WRENCH TO SCREW THE SENSOR INTO THE ACTUATOR.

See section 5.0 of the actuator Installation, Operation and Maintenance manual for software configuration.

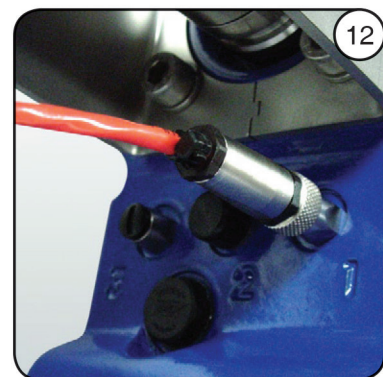

2.2 Assembly of G1 onto Other Valves

Please contact Armstrong for the assembly of the G1 onto other valves. A variety of standard mounting kits and custom mounting kits are available for mounting the Emech actuator onto other valves.

3.0 Electrical Installation



Do not attempt electrical installation unless you are qualified to do so under the laws of your jurisdiction. It is essential that you understand the information in this section to achieve a successful electrical installation. If in doubt, contact Armstrong or its authorized representative.



The wiring of the actuator must be carried out by a qualified technician and according to the instructions described below.

The wire sizes as recommended in the instructions must be adhered to.



Always consider environmental and mechanical conditions of the installation, such as ambient temperatures, chemicals, moisture and exposure to mechanical impacts, shock and vibration.

For mechanical protection of the wiring as well as to comply with EMC (Electro Magnetic Compatibility) standards it is recommended to place the wiring in screened conduit or to use screened cables.

3.1 General Information

The enclosure of the Actuator has two 1/2" NPT cable (or conduit) entry points. Use an appropriate metal conduit adapter (such as Kopex) for these cable entries and use screened (PVC coated metal) Conduit (connected to earth), with appropriate ingress ratings. In case only one entry is being used, leave the pre-installed blanking plug (watertight) for the unused gland hole. Install the conduit as required for the installation and place the wire or cables in the conduit as described in the wiring instructions.

Remove the terminal enclosure cover from the actuator. A terminal with the following wiring layout (Image 3.1 pictured below) will be accessible. Note that the terminal block has a "Warning Label" attached covering all terminal connections except the power supply terminals (not shown). This is to avoid accidental connection of the power supply wires to the loop input terminals, which will permanently damage the unit. It is important to use a correctly rated 3.5AMP (G12 actuator) or 5AMP (G13 actuator) power supply.

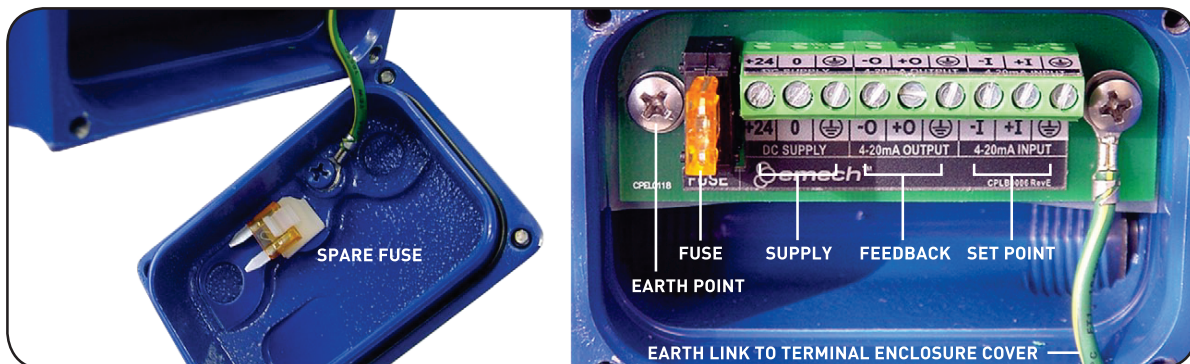

Image 3.1: Terminal enclosure cover removed to expose the wiring terminal.

3.2 Wiring Instructions



WIRE THE SUPPLY FIRST (before making any other connections). Insure that the actuator supply consists of a 24Vdc supply (not AC) and that the voltage tolerances are within the permissible voltage limits of the actuator.

SWITCH THE SUPPLY OFF BEFORE CONNECTING!

3.2.1 Power Supply Wiring

Wire the supply connections as indicted below using the correct diameter shielded cable. When placing the wiring in metal conduit, which is earthed, shielded cable is not required.

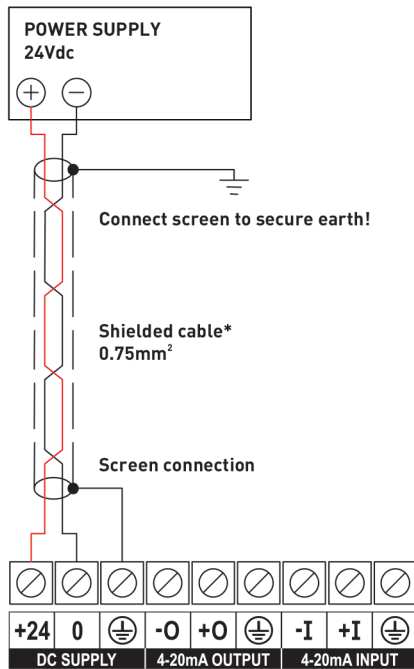

Figure 3.2: Supply Connection



Ensure conduits and wire screens are properly grounded to reduce possible effects of EMI (Electromagnetic Interference) on actuator operation.

REFER to Table 3.1 as a guide for wiring cable lengths and voltage drops.



WARNING !!

When the actuator is wired up to the power supply, it is important that the voltage drop to the actuator remains no more than 1-2Volts when the actuator is operating under load.

To check this, put a meter on the DC supply terminals at the unit, and measure the 24vDC supply. Keeping the meter in place, use the manual handle to move the valve out of position . or change a set value so the actuator is instructed to move.

IF YOU OBSERVE GREATER THAN 2 VOLTS DROP ON THE POWER SUPPLY AT THE ACTUATOR WHEN OPERATING, PLEASE REVIEW AND INCREASE WIRE DIAMETER BEING UTILIZED TO MINIMISE VOLTAGE DROP OVER DISTANCE OF CABLE RUN.

EXCESSIVE VOLTAGE DROP AT THE ACTUATOR UNDER LOAD CAN LEAD TO UNRELIABLE PERFORMANCE AND POTENTIALLY PERMANENT DAMAGE TO THE INSTALLED UNIT.

3.2.2 Power Supply Wire Specification

Consider the minimum cross sectional area and length of the supply cable such that the voltage drop across the total cable length remains within the permissible voltage tolerance of the actuator. For example when using a 0.75mm² cable, the voltage drop will be a 1.2V at 3A and 10m length, which is 5% of the 24V supply. Use the table 3.1 below as a guide to determine cable size and maximum length.

Table 3.1 Cable length (depending on cable area and actuator model)

G12 35Nm Area (mm ²)	Resistance (mOhm/m)	Drop (V/m)	Recommended maximum (m)	Absolute maximum (m)
0.5	0.07	0.21	6	11.6
0.75	0.05	0.14	9	17.3
1.0	0.03	0.10	12	23.1
1.5	0.02	0.07	17	34.7
2.0	0.02	0.05	23	46.2
2.5	0.01	0.04	29	57.8
G13 100Nm Area (mm ²)	Resistance (mOhm/m)	Drop (V/m)	Recommended maximum (m)	Absolute maximum (m)
0.75	0.05	0.23	5	10.4
1.0	0.03	0.17	7	13.9
1.5	0.02	0.12	10	20.8
2.0	0.02	0.09	14	27.7
2.5	0.01	0.07	17	34.7

3.2.3 Wiring of Actuator mA Loop Receiver

To comply with EMC (Electro Magnetic Compatibility) standards, the wiring must be placed in the conduit (must be connected to earth ground) and shielded twisted pair cable (0.25mm²) should be used (see Figure 3.3 below).

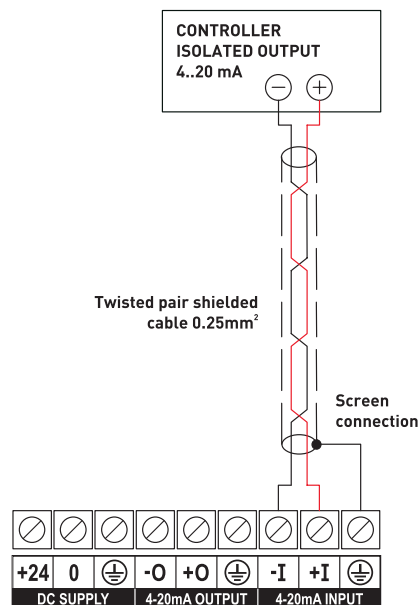

Figure 3.3: Controller with isolated output.

3.2.4 Wiring of Actuator mA Loop Transmitter

To comply with EMC (Electro Magnetic Compatibility) standards, the wiring must be placed in the conduit (must be connected to earth ground) and shielded twisted pair cable (0.25mm²) should be used.

Depending on the type of input available on the controller (PLC), i.e.; isolated mA Loop input (isolated from earth potential Fig. 3.4.) or non isolated input (referenced to earth ground) and if a Loop Supply is available, different wiring schemes are feasible, see figures 3.4 to 3.6 below.

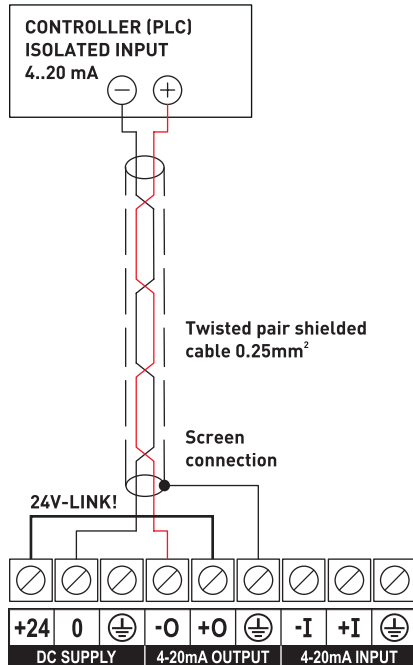

Figure 3.4

Controller with isolated 4-20mA loop input (recommended) using the 24Vdc supply from the actuator by means of a wire link.



Due to this arrangement the loop input is no longer isolated which requires the input on the controller to be isolated!

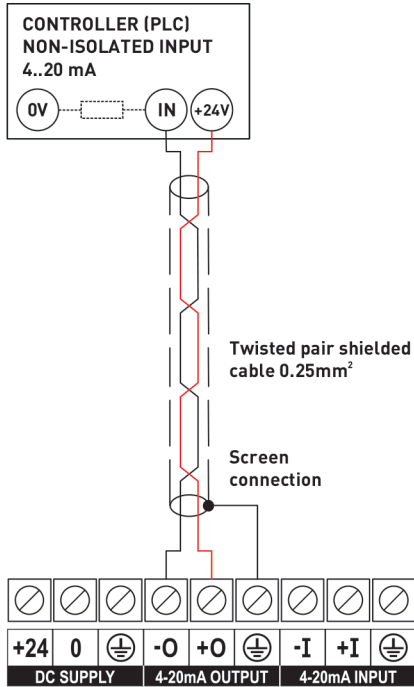

Figure 3.5

Controller with non-isolated 4-20mA loop input using the 24Vdc supply from the controller or PLC itself.
(Recommended)

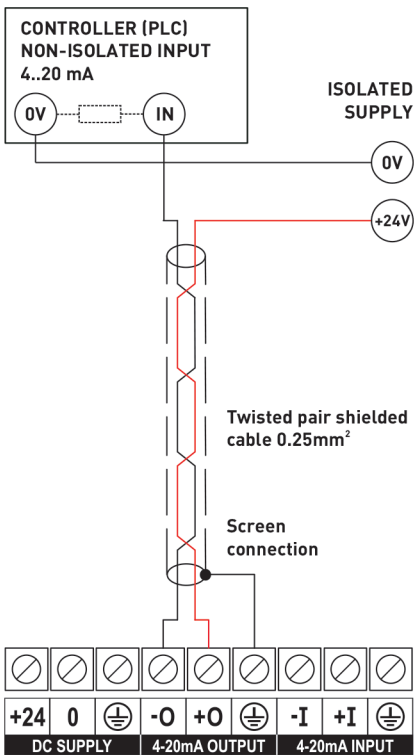

Figure 3.6

Controller with non-isolated 4-20mA loop input using the 24Vdc supply from an external isolated supply.

This could possibly increase noise in the system and is therefore not recommended.

3.2.5 Temperature Sensor Connector (Port-1)

The Sensor Input and internal electronics are specifically designed to take the Emech Temperature Probe.

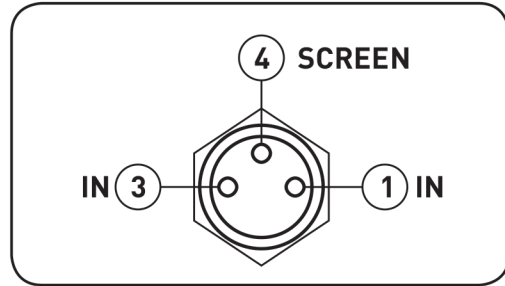

Figure 3.7: NTC connections on actuator mounted M8 female connector (Port-1)

3.2.6 Auxiliary Input (Port-2)

The auxiliary input is set to receive a signal from a binary switch, usually a flow switch, or a flow sensor such as a paddle wheel flow meter output.

The auxiliary input is a 4 pole M8 male connector that accepts a 5-24V configurable active low or high signal to indicate when there is flow.

The 24V output can be used to power the auxiliary port if required. The current draw **MUST NOT EXCEED** 100mA.

For auxiliary signal applications Armstrong can supply a length of cable with a female M8 connector (Part Number: MEC0041). The connector will fit the M8 male plug found on the underside of the actuator labelled "2" (see figure 3.8).

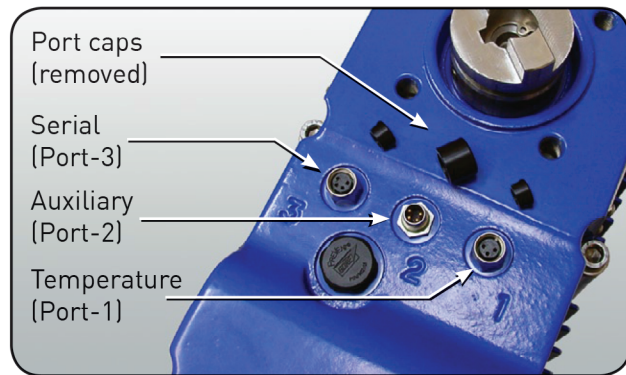

Figure 3.8: The underside of an Emech G1 actuator showing the three port connectors.

The loose end of the cable can be wired to a binary switching device such as a flow switch, flow sensor, level switch, manual switch or used with a PLC. Switching will enable various features of the Emech G1 actuator such as BIGAIN, STANDBY, HOLD, and INVERSE ACTUATOR OPERATION. These features are outlines on the following page and the actuator software configuration are listed in section 5.3.3.

This input can be used in conjunction with the G1 actuator's automatic gain switching feature to allow the actuator to respond appropriately in applications where flow is variable or intermittent.

Figure 3.9 represents the actuator mounted male plug (Port-2) found on the underside of the actuator (see image 1).

The colors indicated in Figure 3.10 are the wire colors of the matching cable and connector auxiliary input cable.

The switching device should be placed between Pin 1 'oV' BLUE and Pin 3 'FLOW' WHITE.

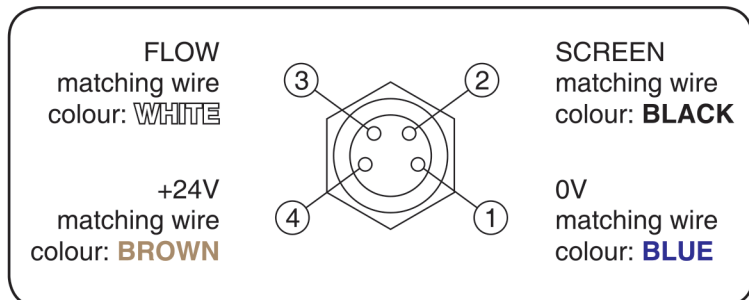

Figure 3.9: Auxiliary input on M8 male connector (PORT-2)

The auxiliary input is primarily used for the four functions listed below. Figure 3.10 illustrates a typical control cycle with an auxiliary input.

NOTE: REFER SECTION 5.3.3 for auxiliary control software settings.

BiGain Control:

Two control gain settings: useful for normal control and an “other” condition were normal gains do not provide stable flow, especially for conditions around the minimum controllable flow rates for Emech control valves.

**StandBy:
(Refer Figure 3.11)**

StandBy pauses the response of the actuator after receiving the enable auxiliary signal. The actuator will remain in the paused position until...

- i) The signal is disabled, in which case the actuator will resume control.
- ii) The pause time expires (StandByTimeout) then the actuator will move to a “Angle StandBy” flow position.

**Hold:
(Refer Figure 3.11)**

The actuator will stay indefinitely in the StandBy position until...

- i) The signal is disabled: then the actuator will go to the HOLD position and either timeout (TimeHold) and return to normal control, OR return to the StandBy position after receiving the enabled signal again.

Inverse Actuator Control Action:

With normal operation the actuator opens counter clockwise from the closed position. Inverse operation implies a clockwise opening direction. This feature is only supported with Emech F4 mixing valves.

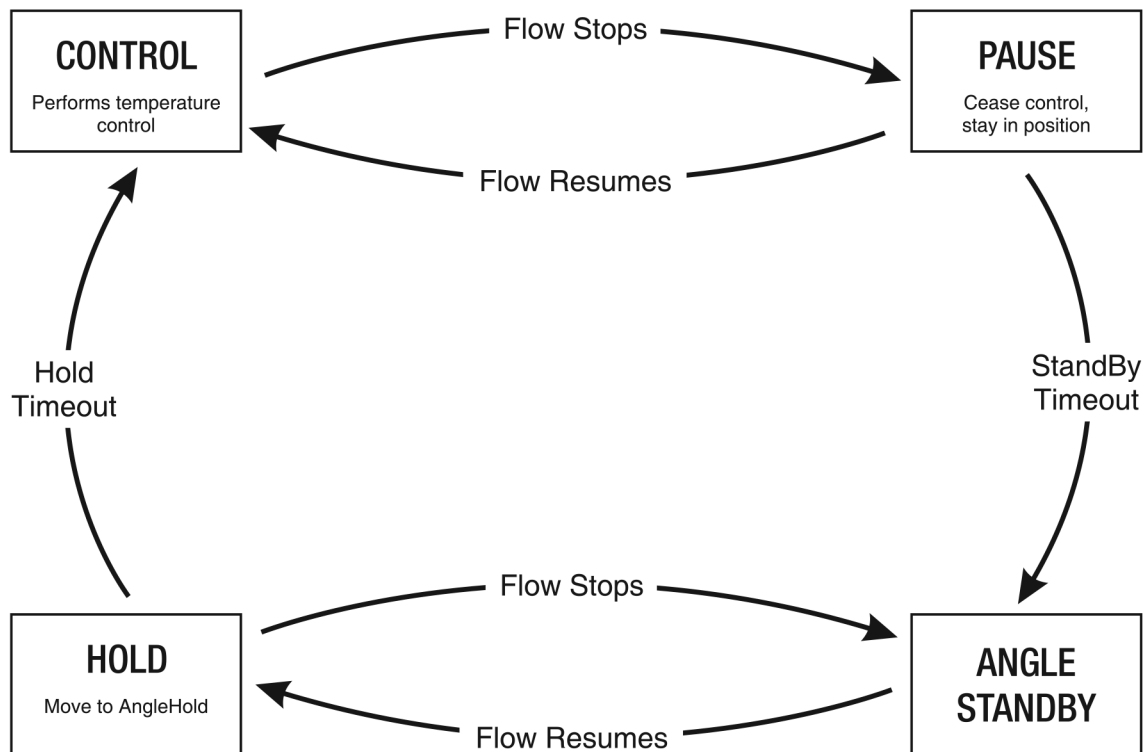

Figure 3.10: StandBy and Hold control cycle.

3.2.7 Serial Port Connector (Port-3)

The actuator can be connected to a standard RS232 serial port for modifying control options using the Emech Configuration Software, EmechConfig, supplied on the Emech Support CD (part number: CPAC0001) and provided Emech Actuator Serial Cable (part number: CPEL0091).



Caution: The Serial Port is intended for diagnostics and configuration only and the length of cable for this connection should not exceed a distance of 10 meters.

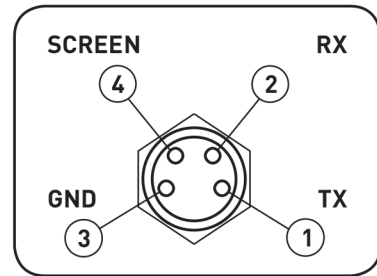

Figure 3.11: RS232 connections on M8 female connector (PORT-2)

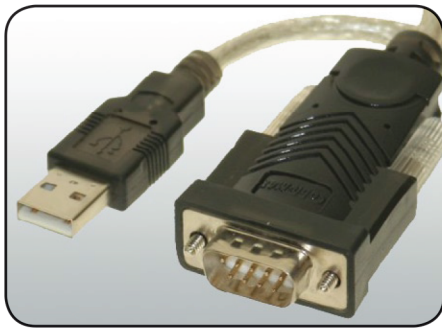

Figure 3.12: USB to Serial adapter

The serial port is provided by means of a 4-pole M8 (female) connector located at the bottom of the actuator housing.

NOTE: For laptops/PC's with no serial port available use a USB to serial adapter (figure 3.12) available from most PC electronics stores.

4.0 Current Loop I/O

The Emech current loop hardware is capable of operating across the standard 4-20mA range. By default the linear control range, for both input and output, has been limited to the range of 5-19mA.

Values outside this range on the loop input represent non-linear behaviors such as closed, cold only or hot only. Values outside the 5-19mA range on the loop output are used to signal error conditions. Contact Armstrong for customized configuration settings.



WARNING !!

The voltage range required for the latest version actuators current loop input will vary from 3.5Vdc for 4mA of current to 5.6Vdc for 20mA of current at the terminals. **Therefore, the PLC controller will need to be setup to provide at the actuator 3.5Vdc at 4mA to a maximum of 5.6Vdc at 20mA.**

If the voltage at the actuator current loop input terminals exceed about 9Vdc or about 50mA threshold, the input circuit protection will be activated and the current loop signal will be clamped to ground. This has the effect of 'locking' out the PLC signal and closing the actuator on "loss of signal". This situation remains until the PLC signal is reduced below this threshold, whereby control is restored. **Therefore, the PLC controller must be setup to avoid sending a current loop signal to the actuator of 50mA or higher.**

4.1 Standard Configuration of Current Loop Input for Temperature Controller Mode

The unit will respond to the current loop input when in REMOTE mode only (Refer to section 6.4). The **full control range** in Temperature Controller mode is 0-100°C or 32-212°F. This corresponds to a Loop Input range of **5 to 19mA**. Calibrate the current loop transmitter (usually an external PLC or Controller) according to the following equations.

Temperature Linear Range Calculation ° Celsius

$$\text{Current input (mA)} = (0.14 \times \text{Temperature required (°C)}) + 5$$

Temperature Linear Range Calculation ° Fahrenheit

$$\text{Current input (mA)} = (0.0778 \times \text{Temperature required (°F)}) + 2.511$$

If given a signal outside the 5 - 19 mA range, the Actuator will not control temperature, but will move to a fixed angle depending on the Actuator configuration. Refer to Figure 4.1 for a graphical description of Loop Input behavior in Temperature Controller mode for several standard configuration types.

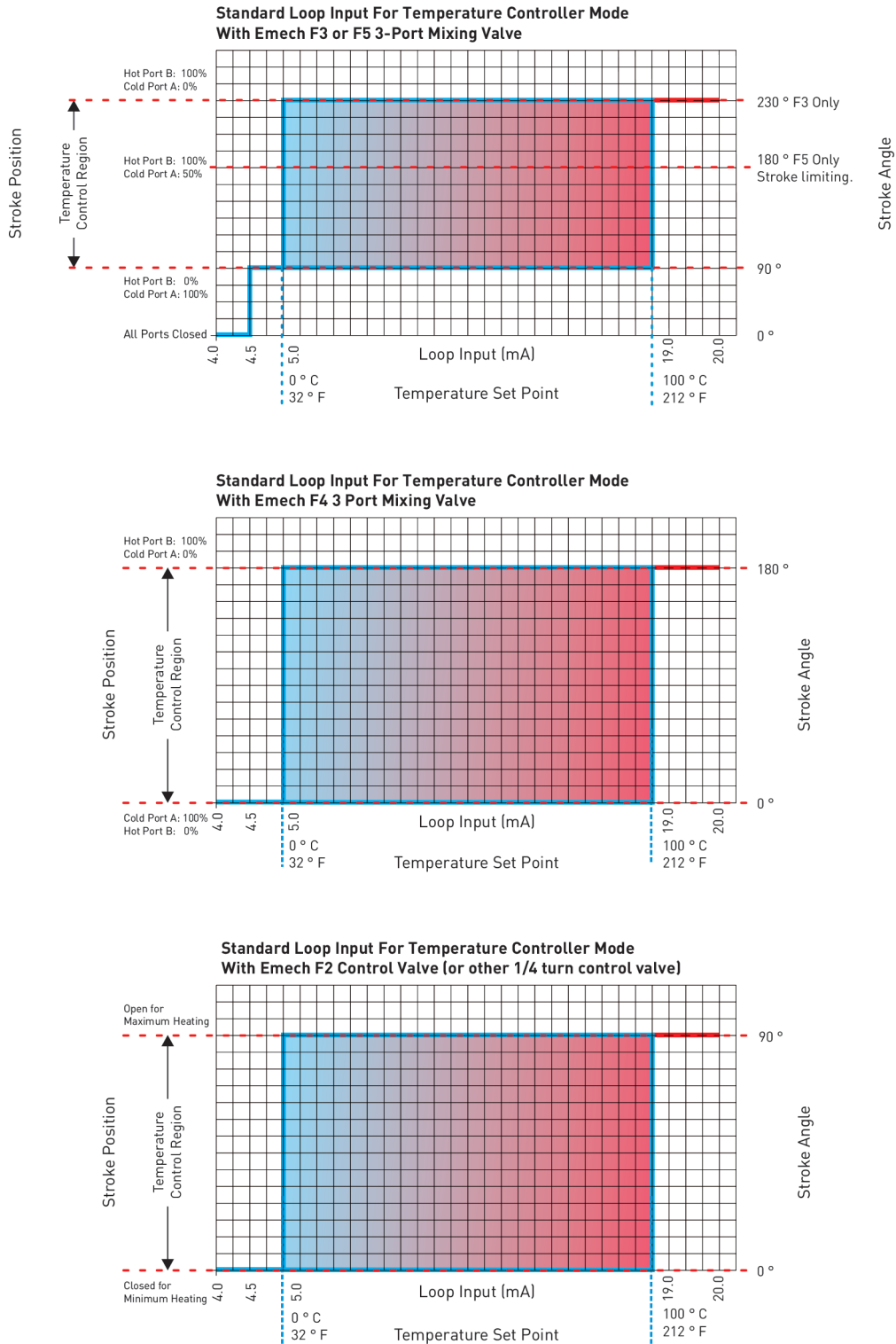

Figure 4.1: Standard Loop Input for Temperature Controller Mode (see page 28).

4.2 Standard Configuration of Current Loop Input for Positioner Mode

The unit will respond to the current loop input when in REMOTE mode only (Refer to section 6.4).
The full control range in Positioner mode is 0-100%, corresponding to a Loop Input range of 5 to 19 mA.
Calibrate the current loop transmitter (usually an external PLC or Controller) according to the equations below.

If given a signal outside the 5-19 mA range, the Actuator will behave according to the response curves given in Figure 4.2. Note that the actual operating stroke is dependent on configuration settings and valve type, Figure 4.2 shows several common configurations.

Position Calculation: % of Max Open Position

For the input current range of 5 to 19 mA and position of 0 to 100% of the maximum open position.
Current input (mA) = (0.14 x Position required (%)) + 5

Position Calculation: 1/4 turn application in Degrees

Current input (mA) = (0.1556 x Position required (°CCW)) + 5

Position Calculation: Emech F3 application in Degrees

Current input (mA) = (0.0609 x Position required (°CCW)) + 5

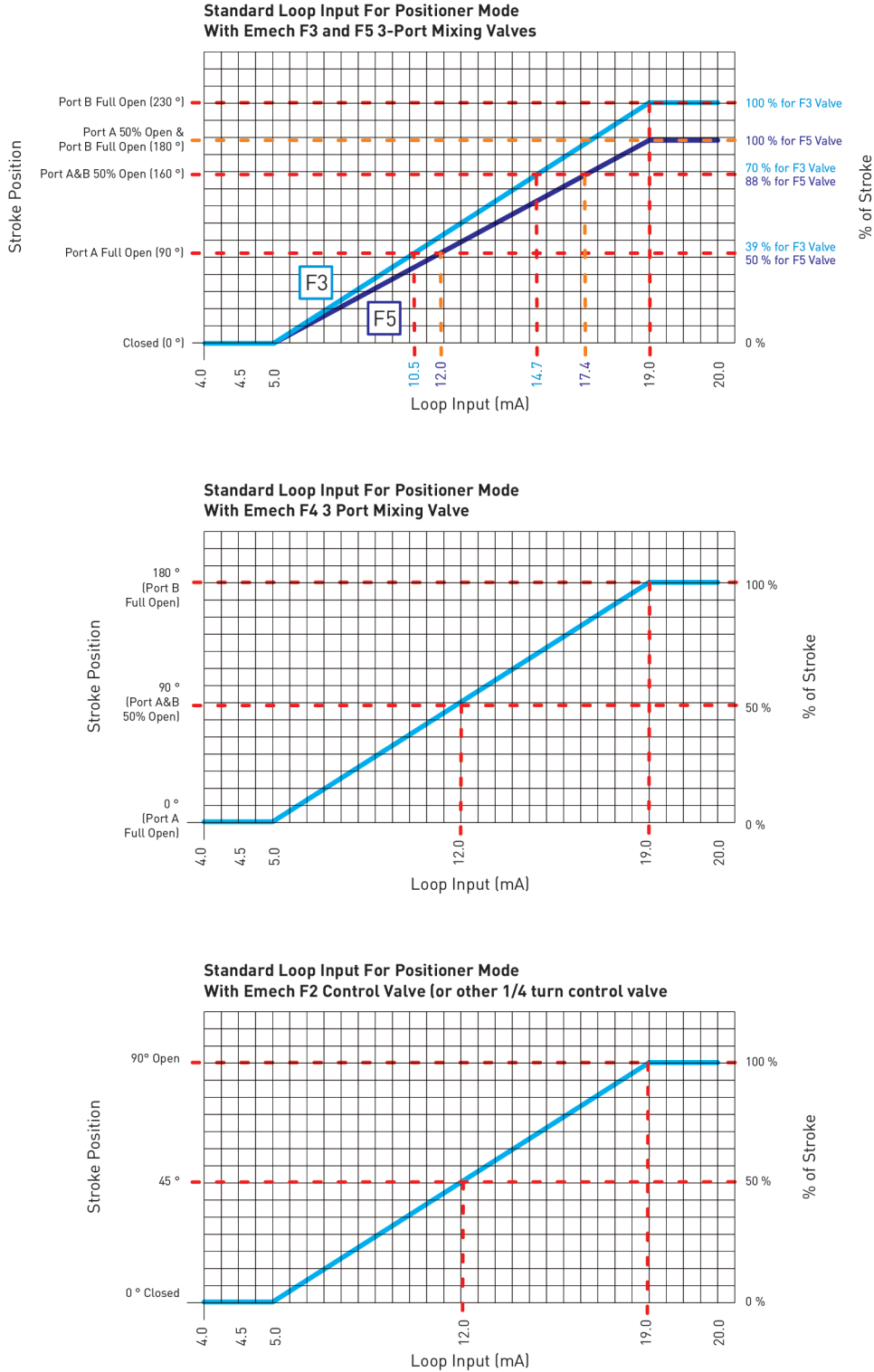

Figure 4.1: Standard Loop Input for Temperature Controller Mode (see page 28).

4.3 Standard G1 Current Loop Output Characteristic

The G1 unit will deliver a current loop output (feedback signal) according to the graphs below. If feedback is required (such as external monitoring), calibrate the current loop receiver (external PLC or controller) according to Fig: 4.3 and Fig: 4.4.

In Temperature Controller Mode, the Actuator will output the current temperature being sensed by the Emech Temperature Sensor and transmit according to the scale shown in Fig. 4.3.

Figure 4.3: Temperature Control

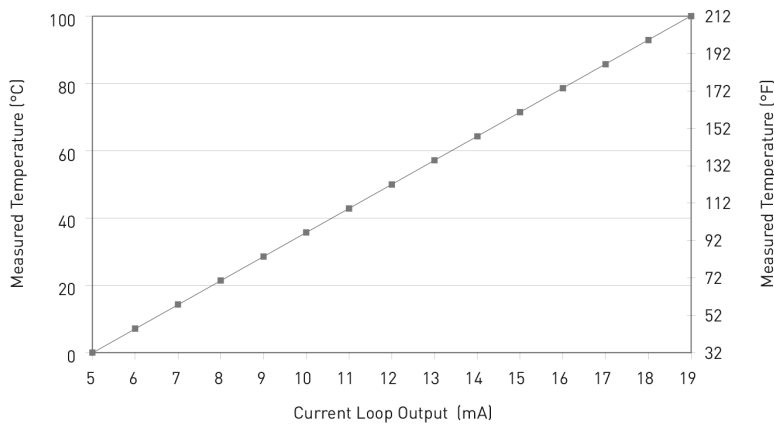
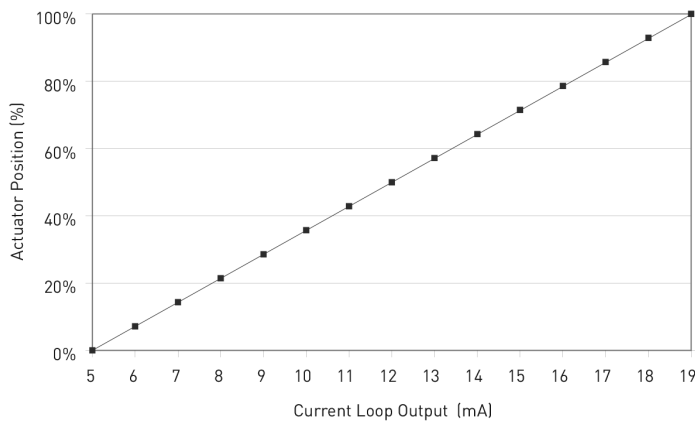

Figure 4.4: Position Control



In Positioner Mode, The Emech actuator has very precise rotational control step resolution of 0.07- 0.8degree rotation for the G12 and G13 respectively for a 0.12mA input increment change;

While the actuator will respond to a minimum 0.12mA loop input change and rotate the actuator at a 0.07degrees rotation movement, the Position Feedback Confirmation mA loop output signal back from the Actuator to the PLC, which confirms the actuator shaft position, as the actuator has an independent confirmation via a lower resolution optical encoder as compared to the stepper motor increments, the confirmation back to the PLC is only approximately every 6 degrees of rotation. Figure 4.4

As can be obtained from the above graphs, the full control range in either Temperature control (0-100°C or 32..212°F) or Position control (0...100%) corresponds to a Loop Output range of 5 to 19 mA (linear response). This has been implemented to obtain the same output loop signal as the input loop=controlling signal when the Actuator is in control.

A loop signal output of 20 mA indicates an error condition. Check the Actuator display for the error number, and see section 6.6 for error code definitions.

Temperature Output Calculation ° Celsius

$$\text{Temperature Output (°C)} = (7.143 \times \text{Current Output (mA)}) - 35.714$$

Temperature Output Calculation ° Fahrenheit

$$\text{Temperature Output (°F)} = (12.857 \times \text{Current Output (mA)}) - 32.286$$

Position Output Calculation % of max open position

$$\text{Position Output (\%)} = (7.143 \times \text{Current Output (mA)}) - 35.714$$

Position Output Calculation 1/4 Turn application in Degrees

$$\text{Position Output (Deg.)} = (6.429 \times \text{Current Output (mA)}) - 32.143$$

Position Output Calculation Emech F3 application in Degrees

$$\text{Position Output (Deg.)} = (16.429 \times \text{Current Output (mA)}) - 82.142$$

5.0 EmechConfig Configuration Software

IMPORTANT: Emech G1 actuators are shipped as a default standard. Emech actuators are configured to the valve type when purchased as a system Model Code ,eg ExxW or ExxS. Advise the factory of any custom or non standard configuration settings on the purchase order at the time of order placement.

The Armstrong Emech Configuration software provides access to configuration of many parameters within the Emech G1 actuator. The software is supplied on the Emech configuration CD (part #CPCA0001). For updated versions of EmechConfig check the Armstrong Website at www.armstronginternational.com/emech.

The software is designed to run on any Win32 system (Windows 95/98/ME/NT/2000/2003/XP). It connects to the Emech actuator through a standard RS232 serial port using the DB9 to DIN cable supplied by Emech (part #CPEL0091).

5.1 Installation

IMPORTANT: Uninstall any earlier versions of the EmechConfig software before installing the latest version. To uninstall, select "Programs>EmechConfig?Uninstall Emech Config" from the Windows Start menu.

After removing any previous version of the software, run the latest installation software supplied on the support CD-ROM. The executable setup file is downloaded from the Armstrong Website , www.armstronginternational.com/emech or supplied. Follow the on screen instructions, selecting an install path for the software. The installation will require around 3.7 MB of local hard disk space.

5.2 Operation

5.2.1 Getting Started

Connect the serial cable between the Emech actuator and the PC. Make sure that the Emech actuator is powered and the push button is pressed for 2 seconds to turn the unit ON. Load the "EmechConfig Software" onto the PC from the supplied CD-ROM (Emech part number CPAC0001) or download it from www.armstronginternational.com/emech.

To start Armstrong EmechConfig, select it from the Start menu, or from the desktop shortcut. To establish a connection with the actuator, it is necessary to tell EmechConfig which COM port to use. This is selected from the COMS menu (shown in Figure 5.1).

NOTE: if you are unsure of the COM port being used you can use the 'Detect Actuator' function from the 'Tools' menu. This will try each available COM port and test for the presence of an Emech actuator (see Figure 5.2).

If the COM port is successfully opened the message 'Opening COM x' will appear in the COMS log in window to the right of the screen. If the COM port is unavailable, the message 'Can't Open COMx' will be displayed. This could be due to another application using the COM port, or that the selected port is not recognized by Windows. In this case, try another COM port or close the application currently using it.

Once the connection is active, a stream of data should begin to appear in the COMS log at the right of the screen. If no activity is observed, check the cable connection and make sure that the correct COM port is selected.

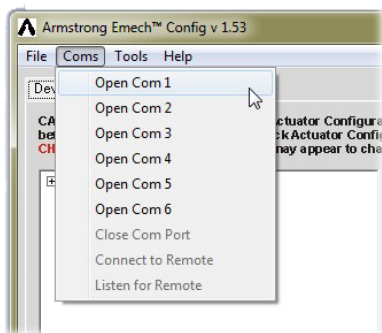

Figure 5.1: Selecting a COM Port.



Figure 5.2: Detecting an Emech actuator if unsure of which COM port to use.



5.2.2 General Use

The Armstrong EmechConfig interface consists of several tabs containing a variety of controls. The most important for configuration of the actuator is the Device Manager tab. This section provides access to information about the actuator, and allows the user to modify some of the permanent settings.

NOTE: 95% of all applications can be set by selecting “Standard Configs” as per Section 5.3.3

The available parameters, called Properties, are displayed in a tree format in the Emech Devices window. This display is operated much like a Windows Explorer display and each item display with a ‘+’ can be expanded to show its child Properties. Each top-level item in the list represents a category of configuration. Expanding these will display a list of available properties.

Clicking on a Property will cause EmechConfig to attempt to read the value of the Property from the actuator’s memory. If the read is successful, the value will be displayed in the ‘Value’ box. If the read fails, then ‘???’ will be displayed indicating that the value is not known. To retry, just click on the Property name again, or click on the ‘Refresh’ button.

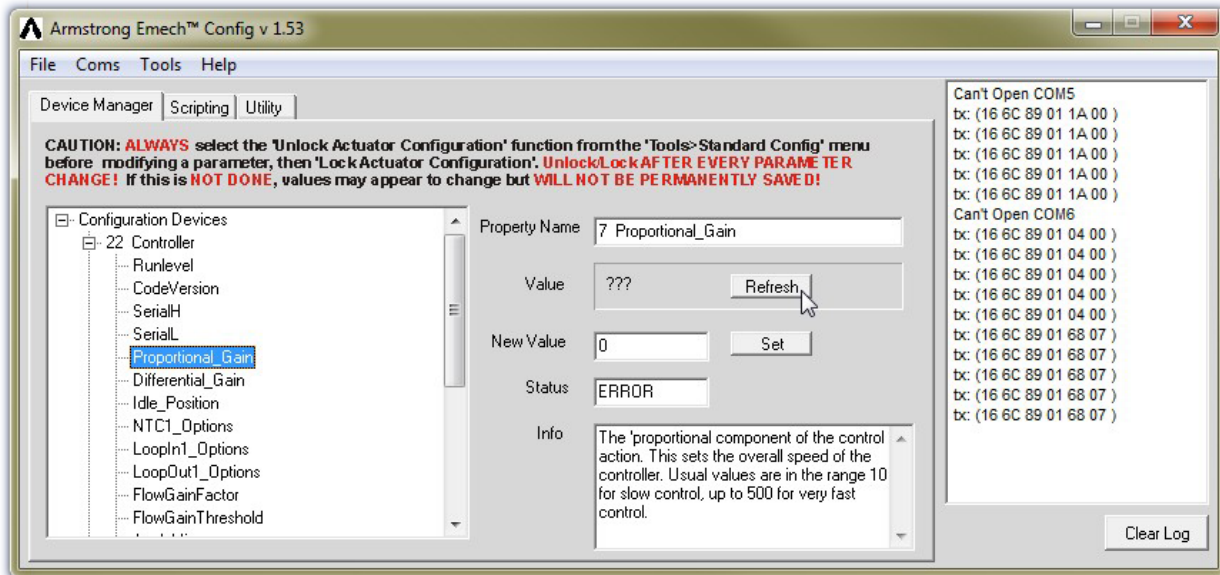

Figure 5.3: Refreshing a Property Value.

5.2.3 Changing Values

The actuator must first be unlocked before any Property values can be changed. Select the 'Unlock Actuator Configuration' function from the 'Tools→StandardConfig' menu as indicated in Figure 5.4.

To alter a Property value, enter a new value in the 'New Value' text box and click the 'Set' button. If successful, the number in the 'Value' box will change to reflect that the update has occurred. Some Properties are not user configurable. When these Properties are displayed, the 'Set' button will be dimmed out.

NOTE: the 'Info' text box displays a description of the Property, guidance for correct use and default values.

After changing a Property value it is important to lock the actuator, otherwise values may appear to change but will not be permanently saved. Select the 'Lock Actuator Configuration' function from the 'Tools→StandardConfig' menu.

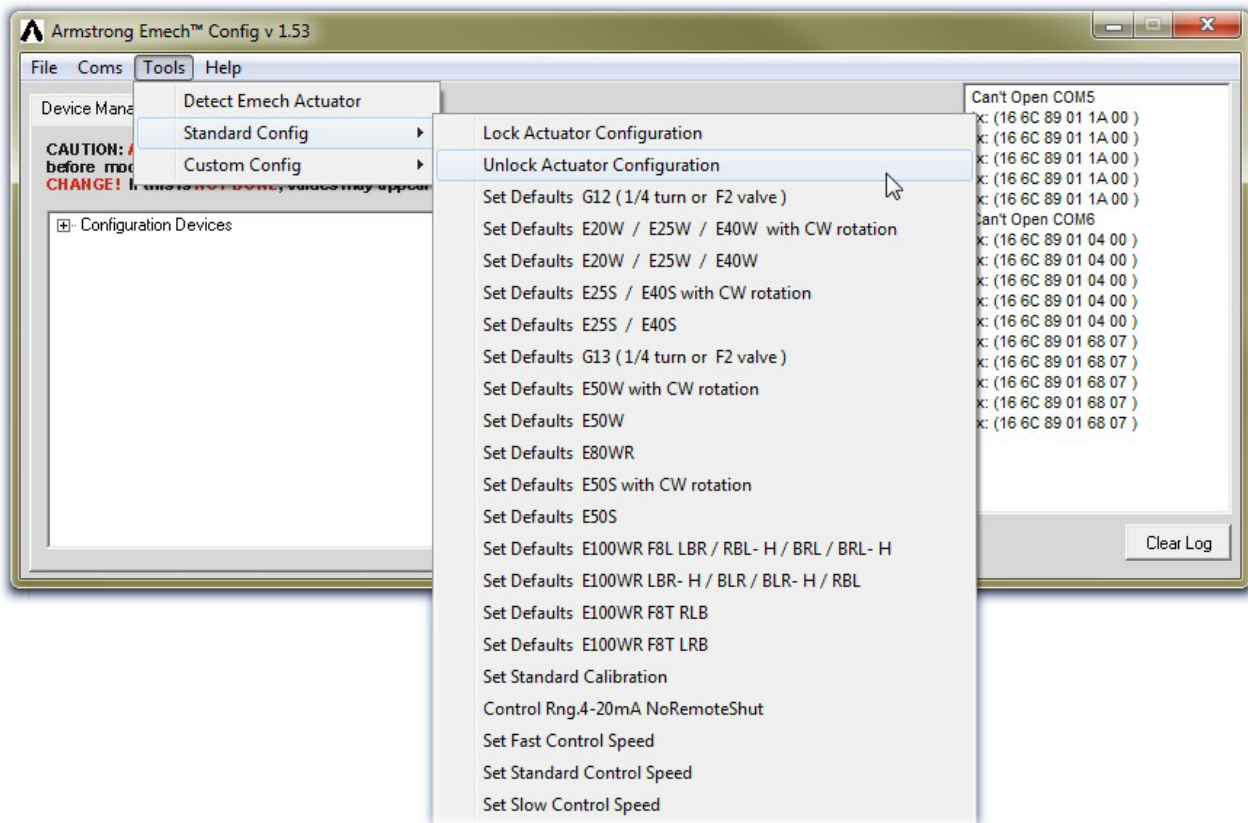



Figure 5.4: Unlock the actuator before attempting to alter any Property values.



ALWAYS select the 'Unlock Actuator Configuration' function from the 'Tools>StandardConfig' menu before modifying a parameter, then 'Lock Actuator Configuration'.

Unlock/Lock AFTER EVERY PARAMETER CHANGE! If this is NOT DONE, values may appear to change but WILL NOT BE PERMANENTLY SAVED!

5.3 Property Categories

5.3.1 Temperature Controller Values

NOTE: 90% of all applications control with the “Tools > StandardConfig > Set Standard Control Speed” setting.

This section contains properties related to closed loop temperature controller mode. The properties in this section that will most often require alteration by the user are the controller gain settings ‘Proportional Gain’ and ‘Differential Gain’.

The G1 Actuator is designed to provide accurate and stable temperature control over a wide range of conditions without altering the default factory setup. However, in some applications it may be necessary to make adjustments to maintain stability of control.

Proportional Gain (P Gain)

This value defines how quickly the Actuator will rotate to compensate for a deviation from the set point. It is the Property that controls the overall speed of the controller. A P gain that is too low will result in a slow response to system disturbances, while a value that is too high may result in instability (oscillation).

Differential Gain (D Gain)

D Gain is best thought of as a compensation factor for lag in the temperature measurement system. It helps to prevent overshoot in response, and to assist in giving quick response to disturbance. In general this is a negative value. A Differential gain that is too small may cause an overshoot. A value that is too large (or a positive value) will cause serious instability.

Table 5.1: Proportional and Differential Gain values.

Controller Gain Setting	Application Description	P Gain	D Gain
Standard (>90% of applications)	Moderate flow without major pressure imbalance.	200	-20
Fast	High flow with well balanced water supply pressures.	500	-50
Slow	Low flow and/or imbalanced supply pressure.	100	-10

5.3.2 Setting “Standard Config” Control Speeds

The G1 actuator can have the gains automatically set to 3 standard values: **Standard**, **Fast** or **Slow**. To select a particular temperature controller speed, follow the menu as per Figure 5.5.

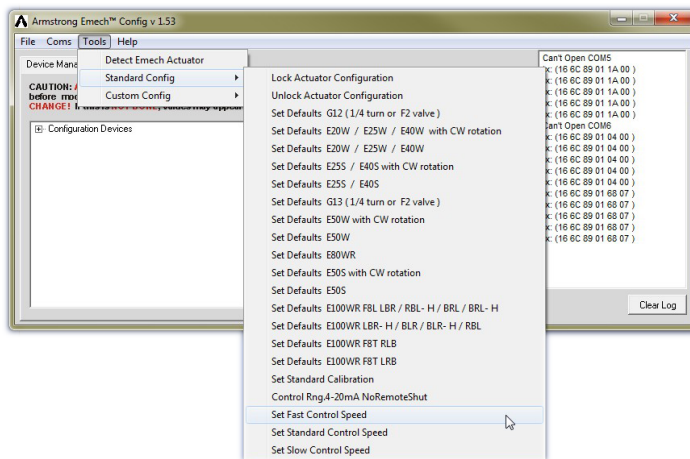

Figure 5.5: Selecting a temperature controller speed.

5.3.3 Auxiliary Controller Values

This section contains Property values related to an input signal to the auxiliary port of the actuator. Refer section 3.2.6 for more information on the auxiliary input. NOTE: These values can only be used on actuators within firmware \geq version 116.

FlowGainFactor This is a positive or negative integer value between “32767” and “1” used to scale the gain settings. A negative value will enable inverse actuator operation. 32767 to 1 can be thought of as a scale factor from 100% (default) to 0.1% of standard control gains. eg: a value of 3277 would REDUCE the gains by 90% (suitable for say a 90% reduction in flow conditions).
When set to “0” it will enable the HOLD and STANDBY features of the actuator.

FlowGainThreshold If set to “-1” will invert the auxiliary signal. “0” is default for standard non-inverted signal.

TimeHold Time to hold before returning to control. 75 equates to 1 second. eg: 300 = Hold for 4 seconds.

TimeOutStandBy Time to pause before proceeding to StandBy. 75 equates to 1 second.

AngleHold The angle the actuator will travel to when in HOLD. VALUE = Angle / 360 x 200 x GB
Note: GB is the Gear Box Ratio for the actuator: G1.2 = “74.1” & G1.3 = “61.8”.

Table 5.2: Configuration Settings for **BIGAIN** Control. (See section 3.2.6.3 for description.)

Property Name	Default Value	Enable Value	Notes
FlowGainFactor	32767	Integer value between 32767 and 1.	Used as a scaling factor for control Gains. eg. 32767 = 1, 24575 = 0.75, 16384 = 0.5, 8192 = 0.25 etc.
FlowGainThreshold	0	0 or -1	A negative value will invert the auxiliary signal.

Table 5.3: Configuration Settings for **HOLD** and **STANDBY**. (See section 3.2.6.3 for description.)

Property Name	Default Value	Enable Value	Notes
FlowGainFactor	32767	Integer value between 32767 and 1.	Used as a scaling factor for control Gains. eg. 32767 = 1, 24575 = 0.75, 16384 = 0.5, 8192 = 0.25 etc.
FlowGainThreshold	0	0 or -1	A negative value will invert the auxiliary signal.
TimeHold	0	See note	Use any integer value, 75 = 1 second.
TimeoutStandBy	0	See note	Use any integer value, 75 = 1 second.
AngleHold	3705 for G1.2 3090 for G1.3	See note	VALUE = Angle / 360 x 200 x GB GB: G1.2 = 74.1, G1.3 = 61.8
AngleStandBy	3705 for G1.2 3090 for G1.3	See note	VALUE = Angle / 360 x 200 x GB GB: G1.2 = 74.1, G1.3 = 61.8

Table 5.4: Configuration Settings for **INVERSE ACTUATOR OPERATION**. (See section 3.2.6.3 for description.)

Property Name	Default Value	Enable Value	Notes
FlowGainFactor	32767	-32767 Note: a negative value is required to inverse actuator operation.	Used as a scaling factor for control Gains. eg. 32767 = 1, 24575 = 0.75, 16384 = 0.5, 8192 = 0.25 etc.
FlowGainThreshold	0	0 or -1	A negative value will invert the auxiliary signal.

5.3.4 Selecting Standard Configuration Sets

EmechConfig comes preloaded with several sets of standard configuration, which can be downloaded to a G1 actuator with a single click.

To access these standard configurations, choose 'Standard Config' from the "Tools" menu. This will show a list of available configurations. Each item represents the combination of a model of Emech Actuator with a particular valve type.

Selecting the appropriate item will initiate the download of the standard settings. The process should take about 10 seconds, and a message will appear confirming that the operation is complete.

NOTE: The configuration software automatically unlocks and locks the actuator when configuring default settings.

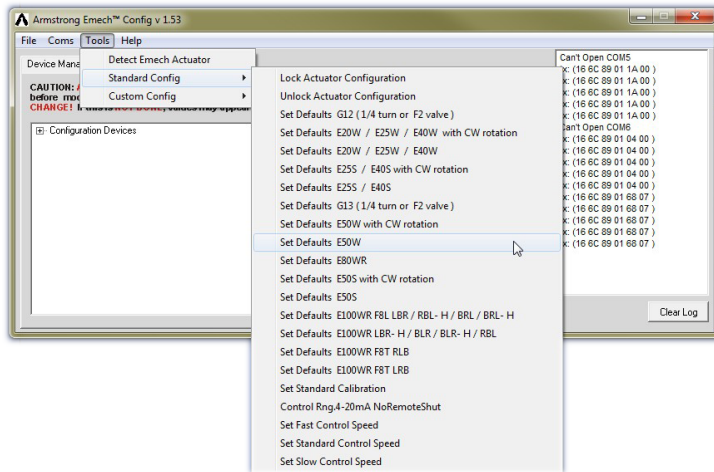

Figure 5.6: Selecting Default Configuration Settings.



Figure 5.7: Confirmation message.

Table 5.5: Standard Configuration Sets.

Name	Description
G12 1/4 turn or F2 valve	Emech G12 Actuator with Emech F2 Valve or any other 1/4 turn valve
E20W / E25W /E40W	Emech G12 Acutator with Emech F3 Valve in sizes 3/4" (20mm) 1" (25mm) 1/1/2" (40mm)
E25S / E40S	Emech G12 Acutator with Emech F5 Valve in sizes 1" (25mm) 1/1/2" (40mm)
G13 1/4 turn or F2 valve	Emech G13 Actuator with Emech F2 Valve or any other 1/4 turn valve
E50W	Emech G13 actuator with Emech F3 Valve in sizes 2" (50mm)
E80WR	Emech G13 actuator with Emech F4 valve in size 3" (80mm)
E50S	Emech G13 actuator with Emech F5 Valve in sizes 2" (50mm)
E100WR F8T LRB	Emech G13 actuator with Emech 4" F8T valve with LRB port configuration

6.0 Keypad Operating Instructions



6.1 'Dual Press' Fail Safe Button Operation

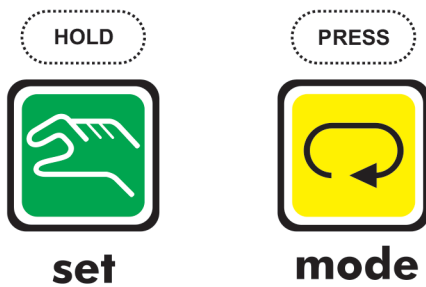

When using the actuator control panel, at least two buttons must be pressed simultaneously to activate any control.

At all times, either the set or mode is to be pressed in conjunction with any other button. This is a fail-safe feature to prevent accidental input.

6.2 Controller type Selection

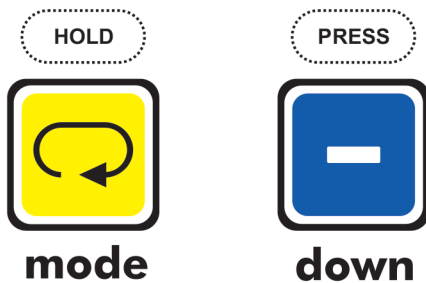

Pressing mode + down (-) selects the particular controller type required.

The control types available depend upon the type of actuator, and always include 'Positioner' control mode, and 'Temperature Controller' mode.



The modes are displayed as codes by the 4 lights on the right of the display.

UNIT INDICATOR				set	+ up	Increase Control Set Point
LED	Temperature	Position			- down	Decrease Control Set Point
1		ON		Pressing 'set' displays Set Point. Normal display is 'present value'.		
2			ON	mode	set	Remote or Local Mode Toggle
UNITS °C °F %				+ up	Temperature Units: °C or °F	
				- down	Position or Temperature Toggle	
				HOLD	PRESS	KEY OPERATION

A key to these codes is displayed on a label attached to the side of the actuator lid above the control panel as shown left.

6.3 Controller Units Selection

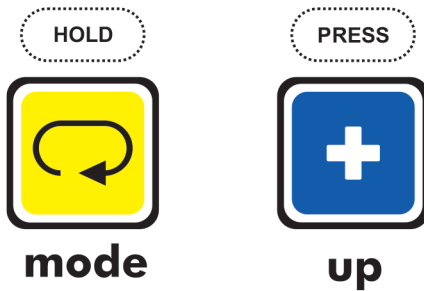

Pressing **mode + up (+)** scrolls through the units displayed for the current controller type.

6.4 Remote & Local Control Toggle

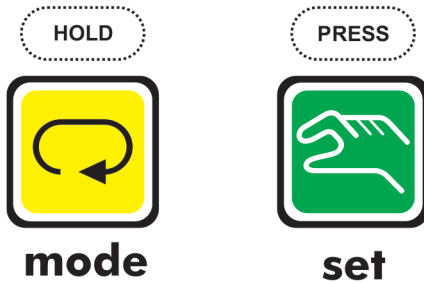

Pressing **mode + set** toggles between local and remote when a remote system is attached to the actuator.



The mode is displayed by the remote light. When NOT lit, the actuator is in Local mode.

6.5 Changing Values (Set Point)

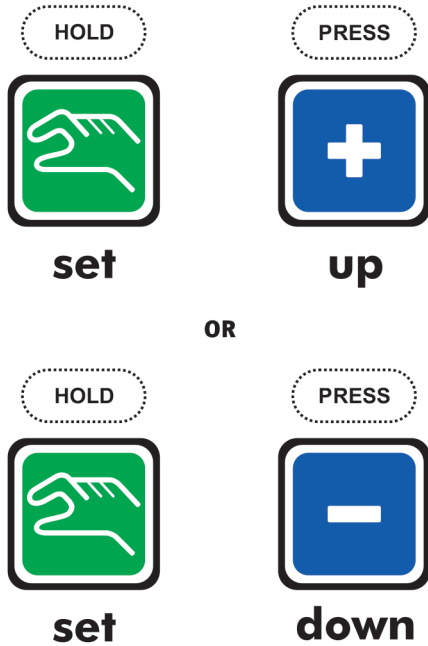

When in Local mode pressing **set** and either **up (+)** or **down (-)** the set point of each controller type can be increased or decreased respectively.



Pressing **set** only will show the local set point or the remote set point depending on which control mode the unit is in.

6.6 Error Codes



The error light shows errors. Flashing and solid lights denote non-critical and critical errors respectively.

See Troubleshooting chart below in section 7.



The error type is displayed with a code from E0 to E9.

Current codes available are:

- E1 = motor driver fault
- E2 = temperature sensor fault (broken or not present)

6.7 Standard Operation Temperature Control

Standard operation can be running in Emech system in “Local Mode” where set point is set on keypad “self temperature control”.

- Emech Actuator system is in:
 - “Local Mode”
 - “Temperature Control Mode Deg F”
- LED “ON” are # 1 (=Deg F)
- LED “OFF” are “Local”
- Temperature Control is via Emech Sensor and Temperature “Set point” on the Emech actuator
 - Temperature set-point via Keypad

Keypad Operating Instructions

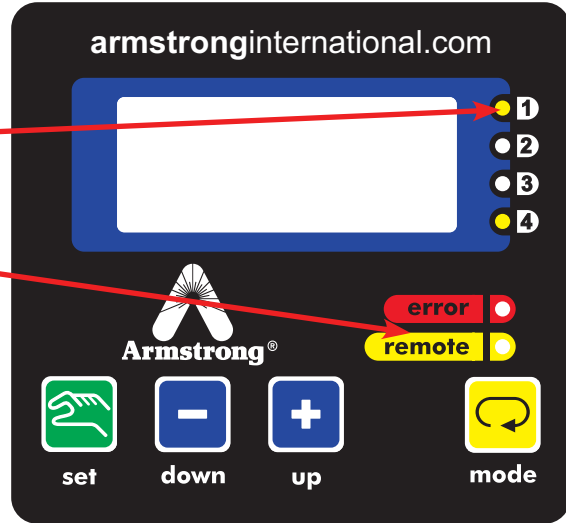

UNIT INDICATOR				set	mode	KEY OPERATION
LED	Temperature	Position				
1		ON		↑ up	↑ up	Increase Control Set Point
2			ON	↓ down	↓ down	Decrease Control Set Point
UNITS	°C	°F	%	set	set	Remote or Local Mode Toggle
				↑ up	↑ up	Temperature Units: °C or °F
				↓ down	↓ down	Position or Temperature Toggle

Pressing 'set' displays Set Point. Normal display is 'present value'.

7.0 Troubleshooting

The actuator is not intended to be serviced or repaired by the customer. Do not take the actuator apart. Return any actuator in need of service or repair to Armstrong's authorized service representative.

Problem	Possible Cause(s)	Corrective Action
Actuator does not respond to current loop reference	Actuator is in LOCAL set mode and REMOTE LED is OFF	Change Actuator to REMOTE mode (Hold Mode and press Set)
Actuator does not function even though power is attached	<ol style="list-style-type: none"> 1. Power push button is set to off 2. Fuse is missing or blown 	<ol style="list-style-type: none"> 1. Press and hold power button for 2 seconds to turn unit on 2. Replace fuse
Actuator does not control temperature to the desired set point	1. Actuator is set to Positioner mode not Temperature Controller mode (LED 2 only is lit)	1. Change to Temperature Controller mode (Hold Mode and press Down (-))
While controlling temperature, actuator moves excessively or oscillates	1. Controller gains are set too high for the current water supply conditions	<ol style="list-style-type: none"> 1a. Decrease and P and D gain until control is stable 1b. Improve water supply pressures to increase outlet flow above nominal minimum controllable flow
Actuator will not control temperature, displays 'E2'	<ol style="list-style-type: none"> 1. Temperature probe is not plugged into actuator 2. Temperature probe is damaged 	<ol style="list-style-type: none"> 1. Ensure probe is securely plugged into actuator 2. Replace temperature probe

Actuator display lights up intermittently, but does not move

Check

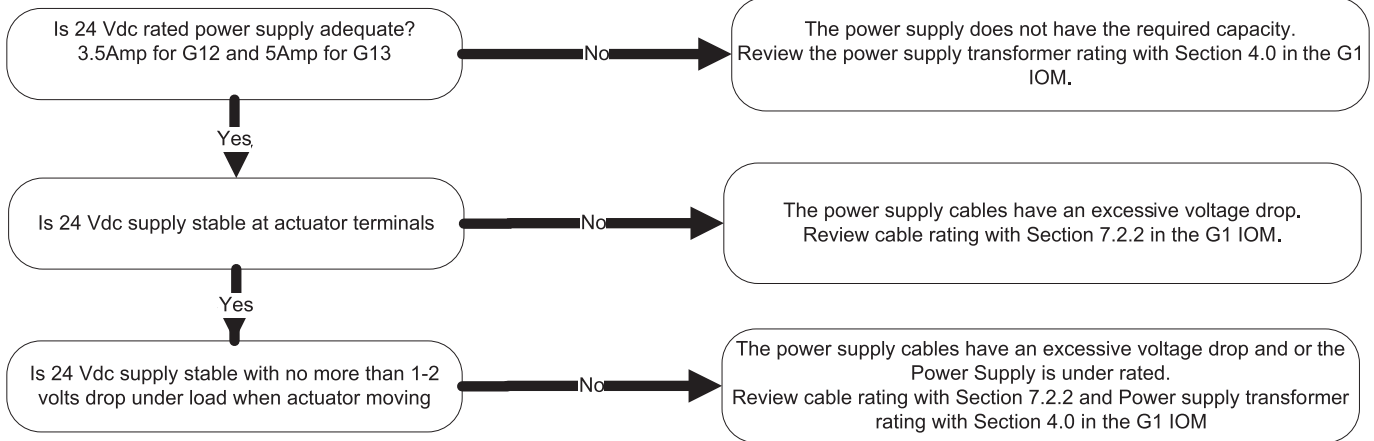

Actuator dead (display not lit, no movement)

Check

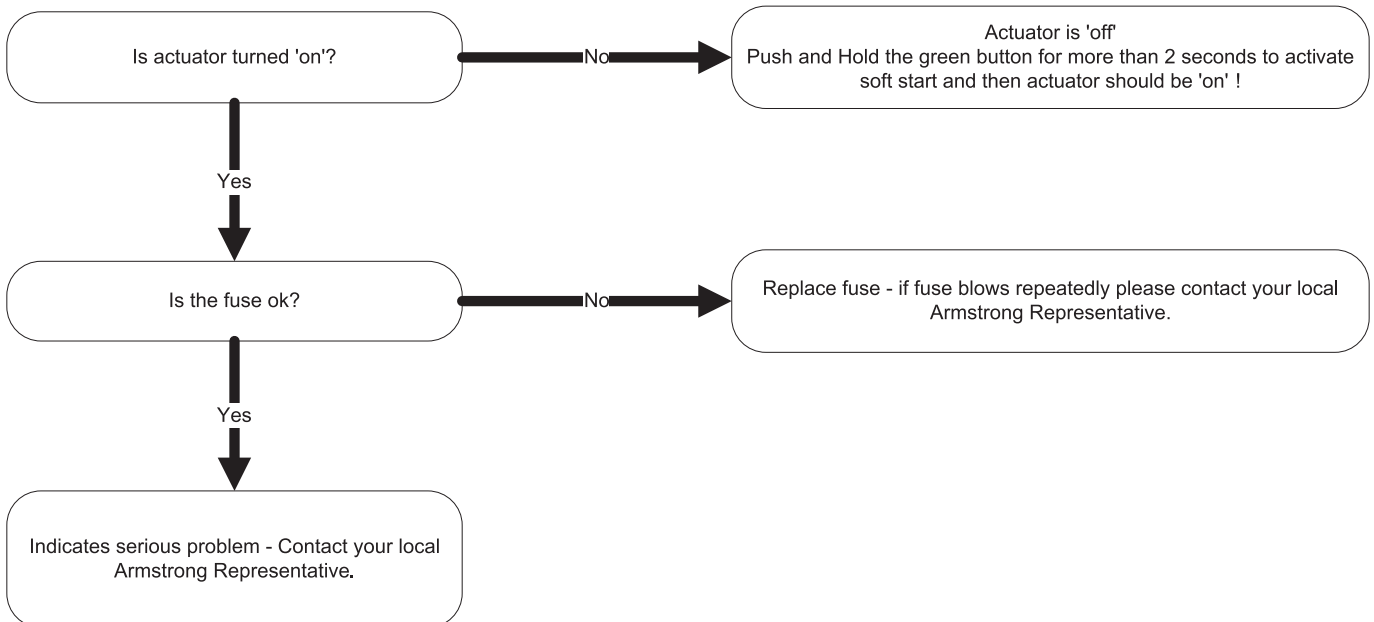

Control is Unstable / Oscillates

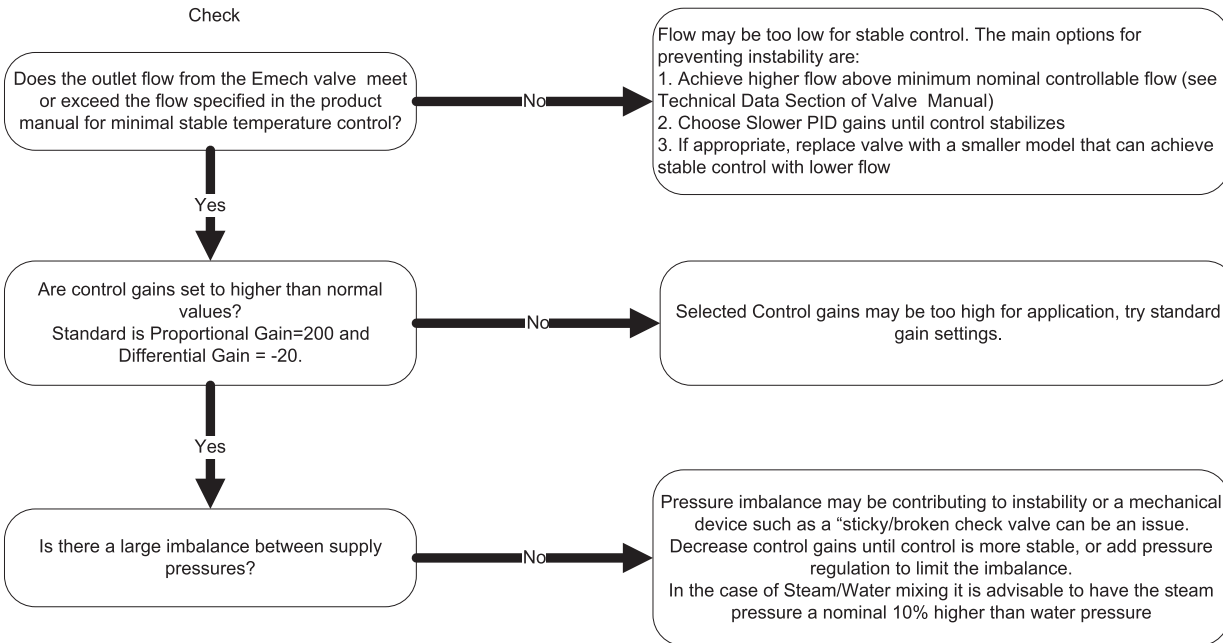

Actuator does not respond as expected to REMOTE current loop signal

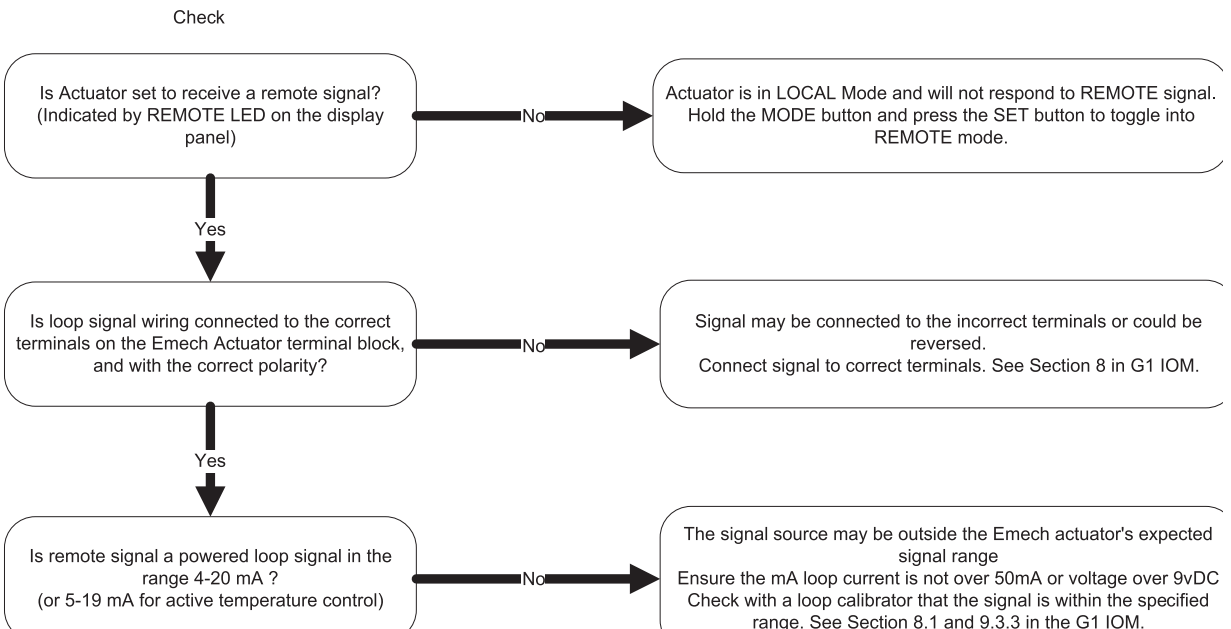

Failure to Reach Set Point

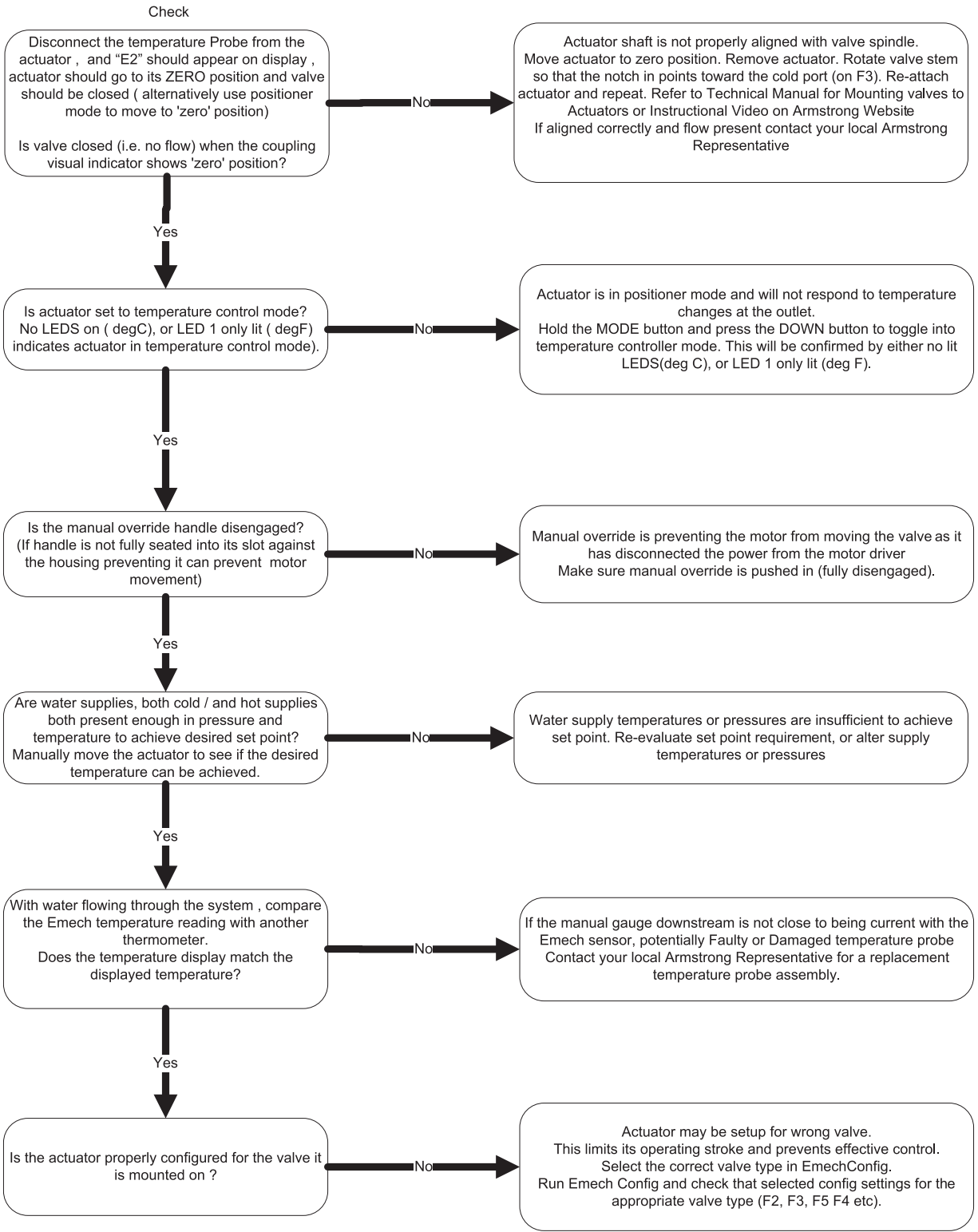

No communication when using EmechConfig Software

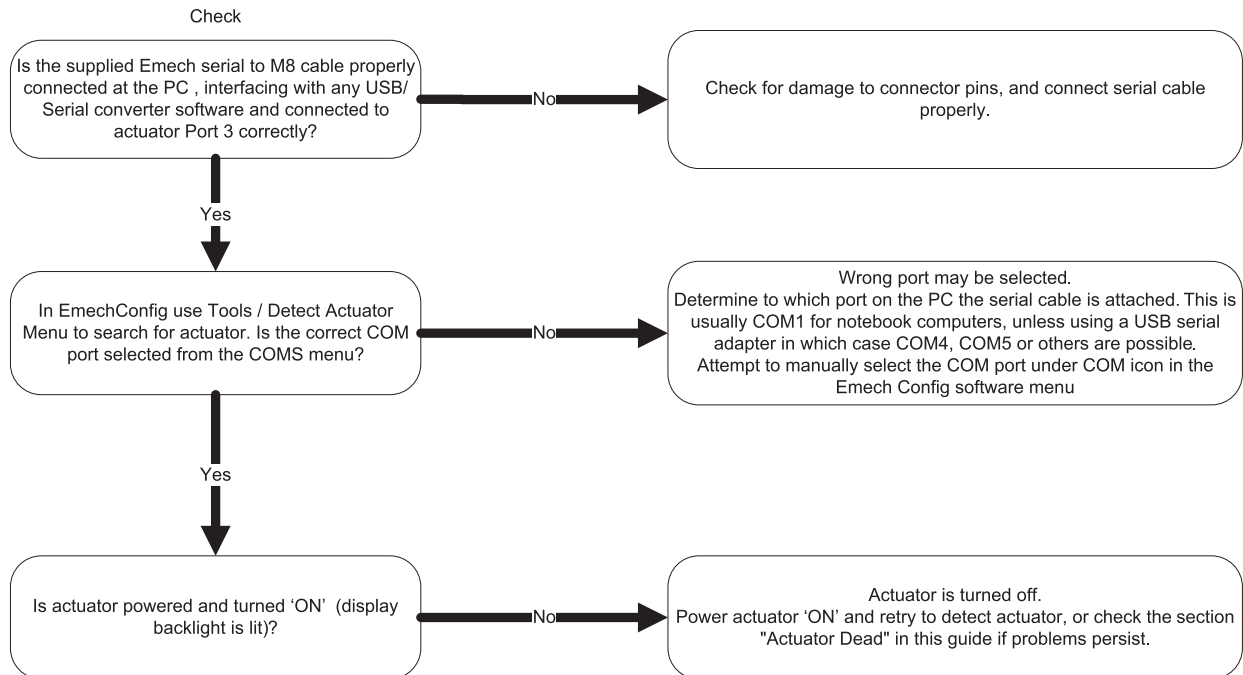

Actuator displays 'E2' when set Temperature Controller Mode

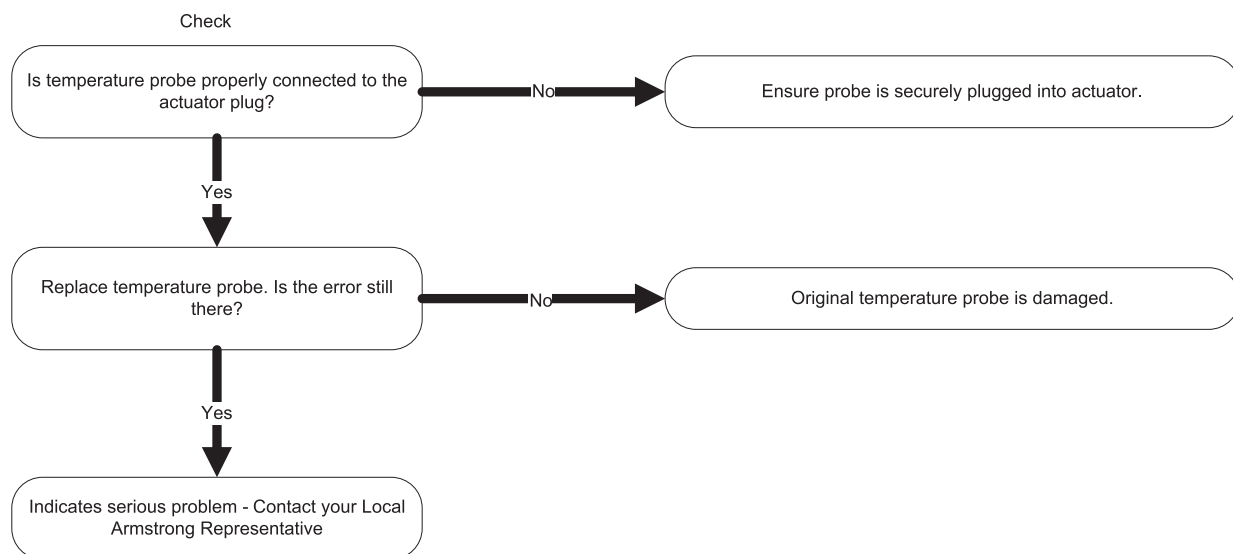

Armstrong Hot Water Group, Inc. (“Armstrong”) warrants to the original user of those products supplied by it and used in the service and in the manner for which they are intended, that such products shall be free from defects in material and workmanship for a period of one (1) year from the date of installation, but not longer than 15 months from the date of shipment from the factory [unless a Special Warranty Period applies, as listed below]. This warranty does not extend to any product that has been subject to misuse, neglect, or alteration after shipment from the Armstrong factory. Except as may be expressly provided in a written agreement between Armstrong and the user, which is signed by both parties, Armstrong **DOES NOT MAKE ANY OTHER REPRESENTATIONS OR WARRANTIES, EXPRESS OR IMPLIED, INCLUDING, BUT NOT LIMITED TO, ANY IMPLIED WARRANTY OF MERCHANTABILITY OR ANY IMPLIED WARRANTY OF FITNESS FOR A PARTICULAR PURPOSE.**

The sole and exclusive remedy with respect to the above limited warranty or with respect to any other claim relating to the products or to defects or any condition or use of the products supplied by Armstrong, however caused, and whether such claim is based upon warranty, contract, negligence, strict liability, or any other basis or theory, is limited to Armstrong’s repair or replacement of the part or product, excluding any labor or any other cost to remove or install said part or product, or, at Armstrong’s option, to repayment of the purchase price. As a condition of enforcing any rights or remedies relating to Armstrong products, notice of any warranty or other claim relating to the products must be given in writing to Armstrong: (i) within 30 days of last day of the applicable warranty period, or (ii) within 30 days of the date of the manifestation of the condition or occurrence giving rise to the claim, whichever is earlier. **IN NO EVENT SHALL ARMSTRONG BE LIABLE FOR SPECIAL, DIRECT, INDIRECT, INCIDENTAL OR CONSEQUENTIAL DAMAGES, INCLUDING, BUT NOT LIMITED TO, LOSS OF USE OR PROFITS OR INTERRUPTION OF BUSINESS.** The Limited Warranty and Remedy terms herein apply notwithstanding any contrary terms in any purchase order or form submitted or issued by any user, purchaser, or third party and all such contrary terms shall be deemed rejected by Armstrong.