



**Armstrong®**

## Flo-Direct® Complete Thermal Exchange Gas Fired Water Heater

### Installation, Operation, and Maintenance Manual



**Warning:** If the information in these instructions is not followed exactly, a fire or explosion may result causing property damage, personal injury, or death.

- Do not store or use gasoline or other flammable vapors and liquids in the vicinity of this or any other appliance.
- What to do if you smell gas
  - Do not try to light any appliance.
  - Do not touch any electrical switch; do not use any phone in your building.
  - Immediately call your gas supplier from a neighbor's phone. Follow the gas supplier's instructions.
- If you cannot reach your gas supplier, call the fire department.
- Installation and service must be performed by a qualified installer, service agency, or gas supplier.

Certified to



U.S. patent 5,924,391



Armstrong International  
221 Armstrong Blvd., Three Rivers, Michigan, 49093 - USA  
Ph. (269) 279-3602 Toll Free (888) HOT-HOSE (468-4673) Fax (269) 279-3130

**Keep this manual with  
heater for future reference.**

# Armstrong

## Contents

<b>Safety</b> .....	1	<i>Upper to Lower Canister</i> .....	22
<b>The Flo-Direct System</b> .....	2	<i>Transfer Pump</i> .....	23
<b>Typical System</b> .....	2	<i>Storage Tank</i> .....	23
<b>Specifications</b> .....	4	<i>Main Power Connection</i> .....	24
<i>Heater</i> .....	4	<b>Operation</b> .....	25
Materials of Construction .....	4	<b>Description of Operation</b> .....	25
Operational Specifications .....	4	<b>Sequence of Operation</b> .....	26
Technical Specifications .....	4	<b>Pre-Start-Up Checklist</b> .....	27
Dimensions .....	5	<b>Commissioning</b> .....	28
Orientation .....	6	<b>Inspecting Installation</b> .....	28
<i>Transfer Pump Assembly</i> .....	8	<b>Inspecting Water System</b> .....	28
Materials of Construction .....	8	<b>Commissioning</b> .....	28
Dimensions and Operational Specifications .....	8	<b>Periodic Maintenance</b> .....	30
Orientation .....	8	<b>Maintenance Schedule</b> .....	30
<i>Storage Tank</i> .....	9	<b>High Temperature Switch Check</b> .....	31
Materials of Construction .....	9	<b>Troubleshooting</b> .....	32
General Specifications .....	9	<b>Troubleshooting Table</b> .....	32
Specifications by Model .....	9	<b>PLC I/Os</b> .....	33
Orientation .....	10	<b>Parts Lists</b> .....	34
<b>Assembly and Installation</b> .....	11	<b>Top Plate</b> .....	34
<b>Unpacking</b> .....	11	<b>Water Train</b> .....	35
<b>Installing Large Heaters</b> .....	11	<b>Control Box</b> .....	36
<b>Installing Small Heaters</b> .....	13	<b>Disconnect Box</b> .....	37
<b>Installing Exhaust Ducting</b> .....	15	<b>Fuel Train</b> .....	38
<b>Installing Intake Air Ducting</b> .....	16	<b>Lower Canister</b> .....	39
<b>Water Connections</b> .....	17	<b>Storage Tank</b> .....	40
<b>Fuel Connection</b> .....	18	<b>Appendix: Modulating Burner</b> .....	41
<b>Electrical Panels</b> .....	19	<b>Descriptions of the major modulation</b>	
<b>Control Panel</b> .....	19	<b>components</b> .....	41
<b>Disconnect Panel</b> .....	20	<b>Operation:</b> .....	42
<b>Heater Label</b> .....	20	<b>Limited Warranty and Remedy</b> .....	44
<b>Electrical Connections</b> .....	21	<b>Notes</b> .....	45
<i>Top Plate to Upper Canister</i> .....	21		



# Safety

## Icon Legend

If instructions are not followed:



— injury or death and property damage are *imminent*



— injury or death and property damage are *possible*



— potential property damage, expensive repairs, and/or voiding the warranty may result

**Warning:** If the information in these instructions is not followed exactly, a fire or explosion may result causing property damage, personal injury, or death.

- Do not store or use gasoline or other flammable vapors and liquids in the vicinity of this or any other appliance.
- What to do if you smell gas
  - Do not try to light any appliance.
  - Do not touch any electrical switch; do not use any phone in your building.
  - Immediately call your gas supplier from a neighbor's phone. Follow the gas supplier's instructions.If you cannot reach your gas supplier, call the fire department.
- Installation and service must be performed by a qualified installer, service agency, or gas supplier.

**Note:** Operating with any safety device bypassed will void the warranty.

- Applicable codes must be followed and supersede any other instructions. Generally applicable codes in the US include:
  - NEC
  - NFPA #86

- Read this manual.
- Improper installation or operation may cause a fire or explosion resulting in property damage, personal injury, or death. Armstrong strongly recommends that a qualified installer be used.
- Service must be performed by a qualified person.
- Improper installation, start-up, operation, maintenance, or service may void the warranty.

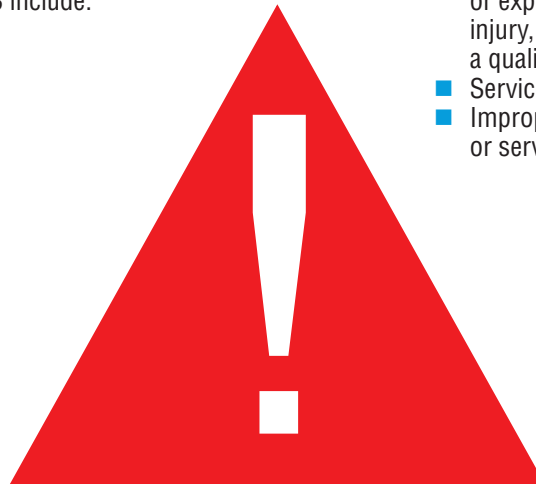

- Hot water or metal may cause scald burns. Skin exposure to 140° water or metal for only five seconds may cause a second degree burn.

- Do not attempt to use the heater if it has been submerged in water. Contact a qualified service technician to inspect it and replace compromised parts.



# The Flo-Direct System

Armstrong's Flo-Direct water heaters:

- Are designed for industrial applications
- Use complete thermal exchange technology
- Come in sizes from 1 to 16 million Btu/hr
- Heat water up to 185 °F maximum

## Typical System

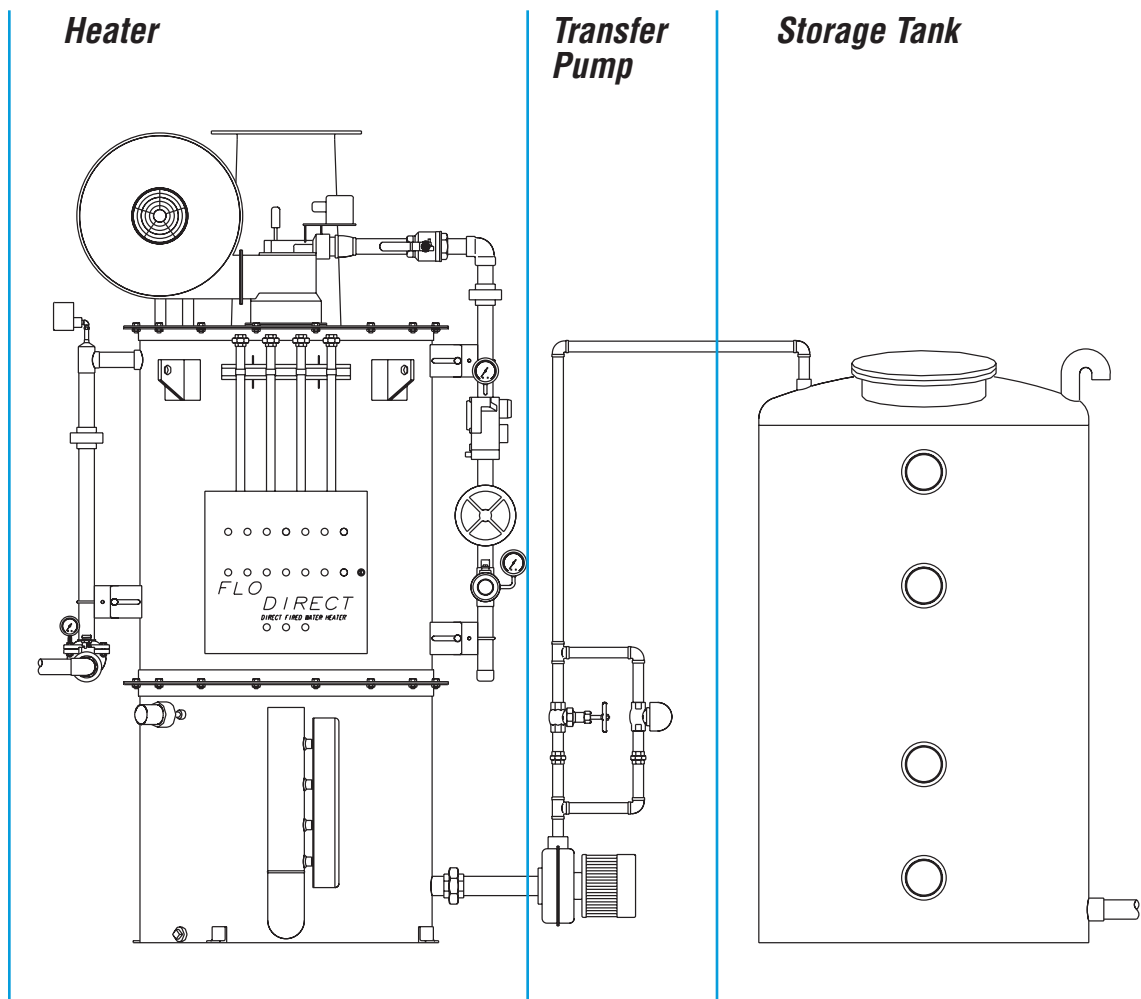

Armstrong reserves the right to make design or specification changes without notification.



Flo-Direct water heaters are highly efficient, low maintenance systems.

- Complete thermal exchange technology means no fuel is used for warm-up or idle time and no energy is lost through conversion or exchange.
- Without internal moving parts, there is very little to maintain.
- Water conditioning is not required.

Flo-Direct systems are highly customizable at both a system and component level. ***The information in this manual generally uses a 5 million Btu/hr unit and is intended to be typical. Illustrations are not intended to be complete or correct in every detail. System-specific drawings, including wiring schematics, are provided with each unit and should be referred to when installing and operating your system.***

Common options:

- Gravity drain (without a transfer pump)
- Standard (consistent incoming water temperature) or modulating burner actuator
- Natural gas or propane fuel
- Remote or integral tank

Other available options include:

- Skid-packaged heaters
- Performance matched components
- Ultra-low NO<sub>x</sub> emissions
- Non-standard fuels
- Storage tank heating element

Peripheral components:

- Digital mixing valves
- Variable frequency drive pump
- Hose stations

Optional services:

- Turn-key installation
- Installation project management
- System assessment and optimization
- Energy conservation measures (ECM)

For further information, visit <http://www.armstronginternational.com/flo-direct> or contact Armstrong.

**Note:** Armstrong provides separate IOMs for the burner, blower, and for optional components. Consult the appropriate document for more information.

# Specifications

## Heater

### Materials of Construction

Component	Material
Canister	304 SS (10 ga. ≤ AFD-8000; 3/16 > AFD-8000)
Canister gasket	WARCO white (food grade buna rubber)
Flame tube	304 SS
Gas piping	Malleable iron with standard yellow finish
Water piping	Copper with brass or bronze fittings OR welded SS
Spray ring	304/316 SS
Pall ring	304 SS

### Operational Specifications

Spec	English Units	SI Units
Gas supply pressure	2–6 psig (optimum 4–5.5 psig)	0.14–0.41 bar (optimum 0.28–0.38 bar)
Water supply pressure	30–100 psig with ± 5 psig variation	2.07–6.84 bar with ± 0.34 bar variation
Inlet water temperature	32 °F to 120 °F	0 °C to 49 °C
Outlet water temperature	185 °F	85 °C
Water temperature differential	10 °F to 140 °F	5.6 °C to 77.8 °C
NOx emission	30–50 ppm	
Thermal efficiency	99.7%	

### Technical Specifications

- Flo-Direct water heaters are built to UL standard 795
- May be manufactured to comply with various other electrical or water quality standards
- Three-phase power is required; most available voltages may be accommodated

# Dimensions

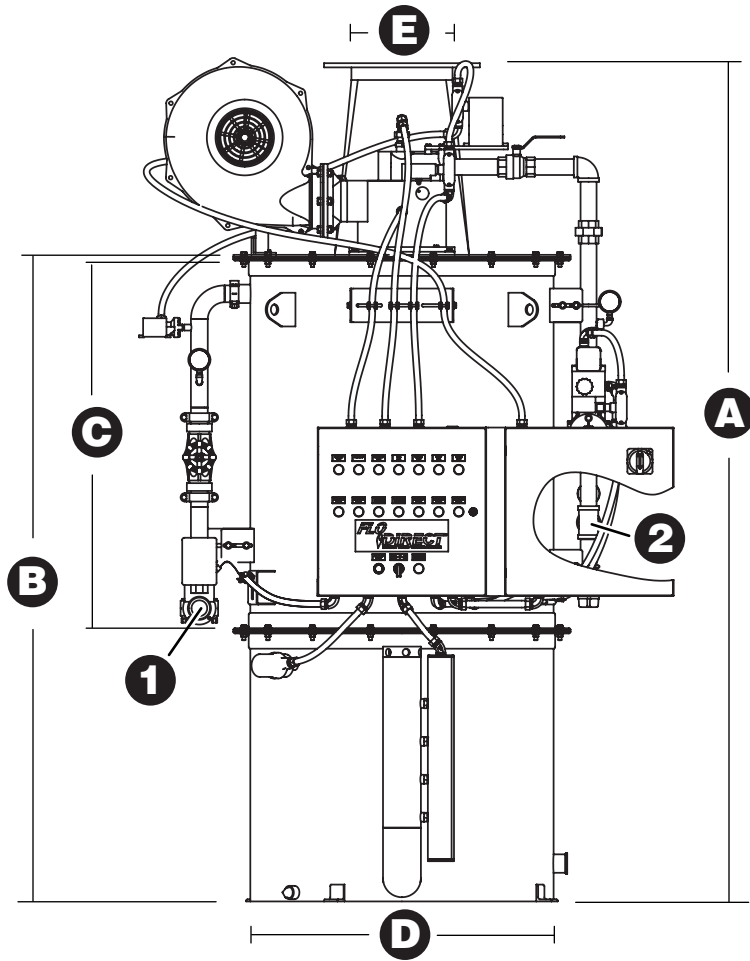

Model	Connections*				Dimensions										Weight		Btu/hr	kW
	1		2		A		B		C		D		E		lb	kg		
	in.	mm	in.	mm	in.	mm	in.	mm	in.	mm	in.	mm	in.	mm				
AFD-1000	1	25	1	25	95	2413	71	1803	39	991	24	610	8	203	825	375	1,000,000	292
AFD-1500	1	25	1	25	97	2464	73	1854	41	1041	26	660	8	203	850	386	1,500,000	439
AFD-2000	1-1/2	40	1-1/2	40	100	2540	76	1930	44	1118	30	762	10 3/4	273	1500	680	2,000,000	585
AFD-3000	2	50	1-1/2	40	100	2540	76	1930	44	1118	36	914	12	305	1600	725	3,000,000	878
AFD-4000	2	50	2	50	104	2642	80	2032	48	1214	40	1016	14	356	2000	907	4,200,000	1171
AFD-5000	2-1/2	65	2	50	127	3226	97	2464	65	1651	44	1118	16	406	2500	1136	5,300,000	1464
AFD-6000	3	80	2	50	132	3353	100	2540	70	1778	47	1194	18	457	2900	1316	6,300,000	1757
AFD-7000	3	80	2	50	139	3531	107	2718	77	1956	50	1270	18	457	3200	1455	7,400,000	2050
AFD-8000	3	80	2	50	139	3531	107	2718	77	1956	50	1270	18	457	3200	1455	8,400,000	2342
AFD-9000	3	80	2	50	169	4293	139	3531	107	2718	60	1524	20	508	5000	2273	9,500,000	2635
AFD-10000	3	80	2	50	181	4597	151	3835	119	3023	61	1549	20	508	5200	2405	10,500,000	2928
AFD-11000	4	100	3	80	181	4597	151	3835	119	3023	61	1549	22	559	5500	2495	11,600,000	3221
AFD-12000	4	100	3	80	181	4597	151	3835	119	3023	61	1549	22	559	5500	2495	12,600,000	3514
AFD-13000	4	100	3	80	192	4877	161	4089	129	3277	70	1778	24	610	7000	3175	13,700,000	3807
AFD-14000	4	100	3	80	192	4877	161	4089	129	3277	70	1778	24	610	7000	3175	14,700,000	4099
AFD-15000	4	100	3	80	192	4877	161	4089	129	3277	70	1778	24	610	7000	3175	15,800,000	4392
AFD-16000	4	100	3	80	216	5486	185	4699	153	3886	70	1778	24	610	7500	3402	16,000,000	4685

\*Connections may be NPT, flanged, or use a sanitary ferrule as required.

# Orientation

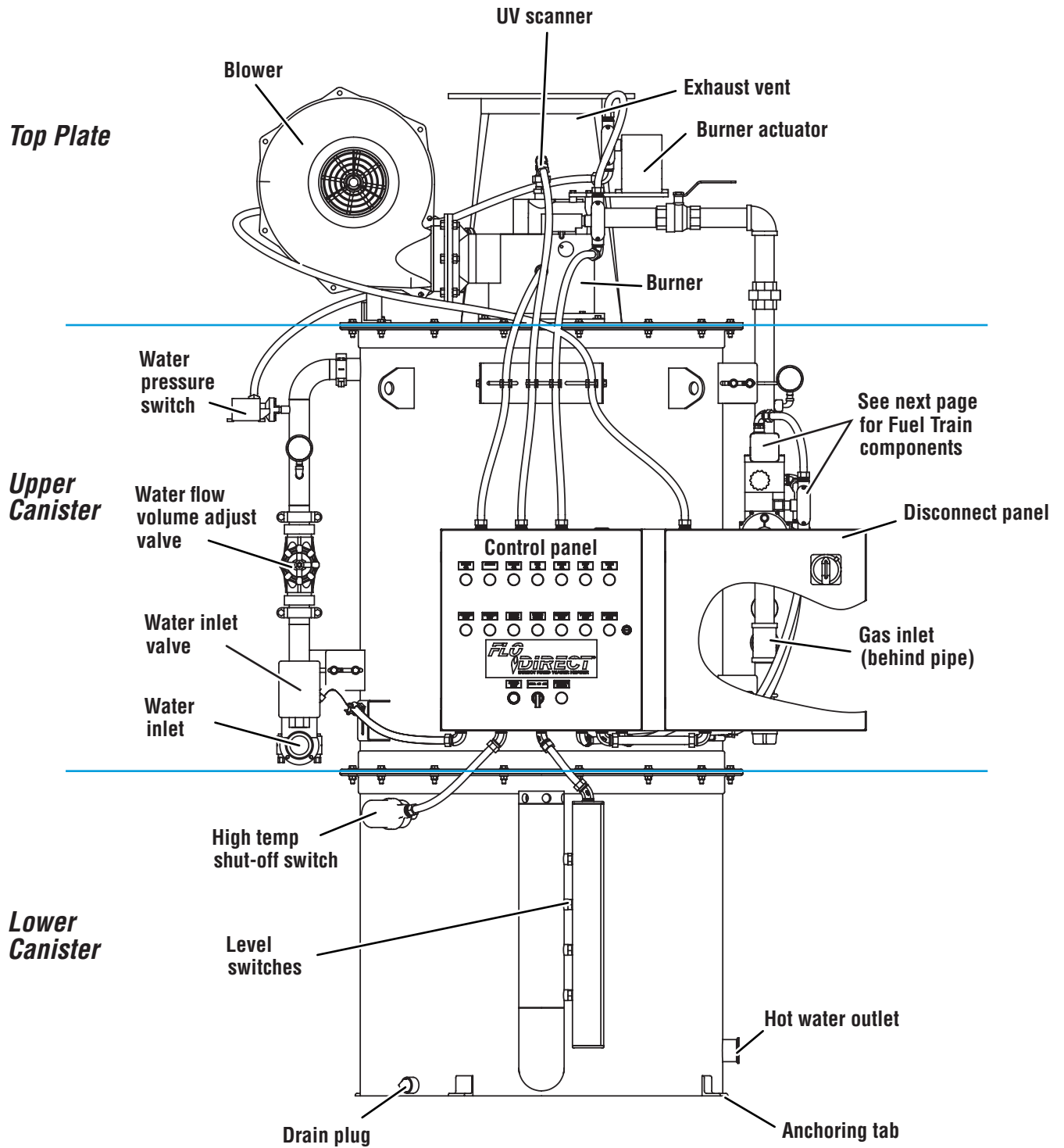



## Fuel Train Components

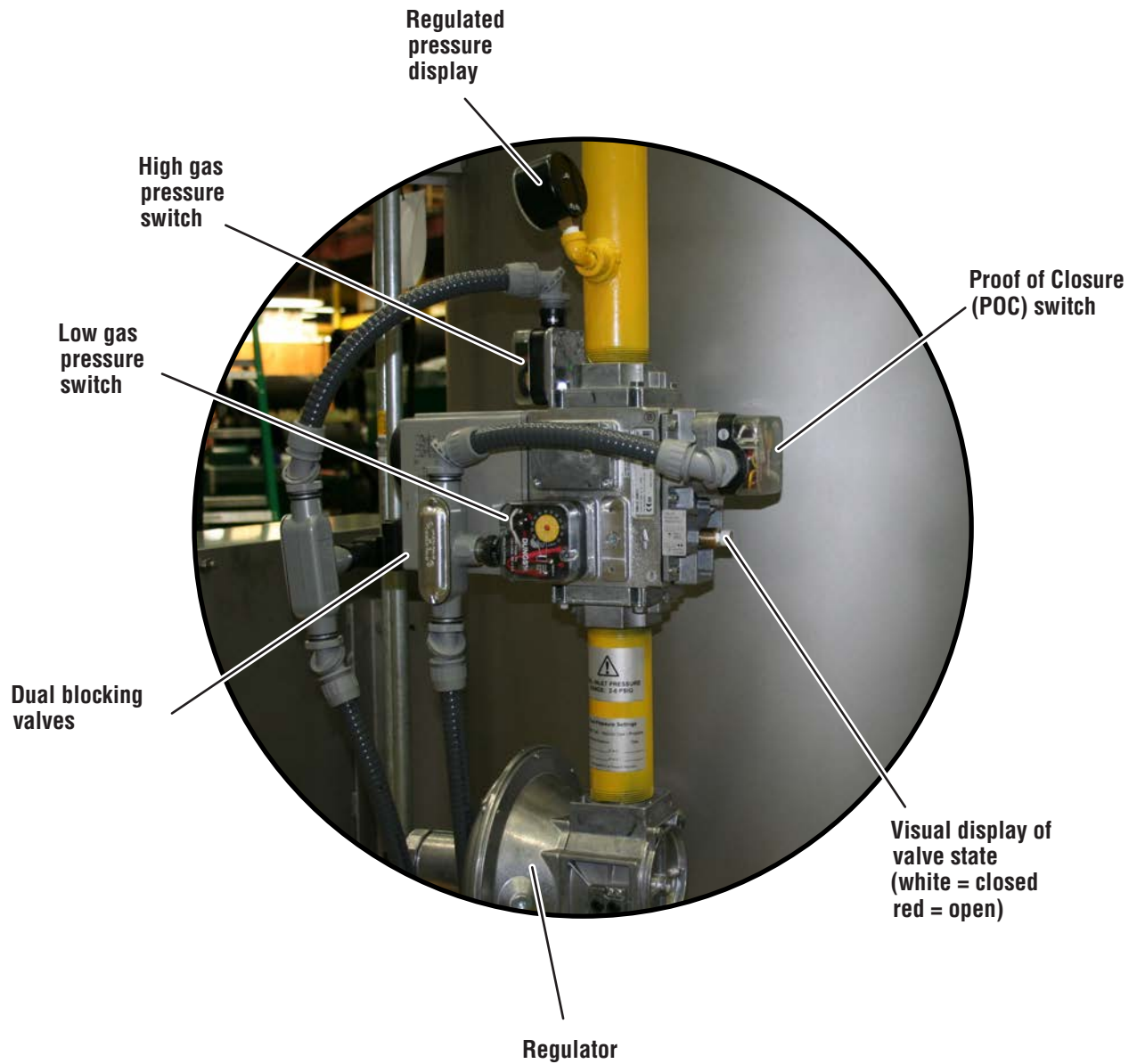

# Transfer Pump Assembly

## Materials of Construction

Component	Material
Piping	Type L hard copper/welded 304 OR 316 stainless steel
Braided flex hose	Stainless steel
Pump	Stainless steel (TEFC motor)
Bypass valve	Bronze (110 VAC solenoid/stainless steel motorized butterfly valve)
Globe valve	Bronze/stainless steel
Stand	Carbon steel (painted)

## Dimensions and Operational Specifications

Model	Maximum Flow Rate		Inlet Connection		Outlet Connection		Flow Control Valve		Bypass Valve		Pump Power	
	GPM	m <sup>3</sup> /hr	in.	mm	in.	mm	in.	mm	in.	mm	HP	kW
TP-50	50	11.4	1-1/2	40	1-1/2	40	1	25	1	25	2	1.49
TP-90	90	20.4	1-1/2	40	2	50	1-1/2	40	1-1/2	40	3	2.24
TP-135	135	30.7	2	50	2-1/2	65	2	50	1-1/2	40	5	3.73
TP-200	200	45.4	2-1/2	65	3	80	2	50	2	50	7-1/2	5.59
TP-275	275	62.5	2-1/2	65	4	100	2-1/2	65	2	50	10	7.46
TP-350	350	79.5	3	80	4	100	3	80	2	50	10	7.46

## Orientation

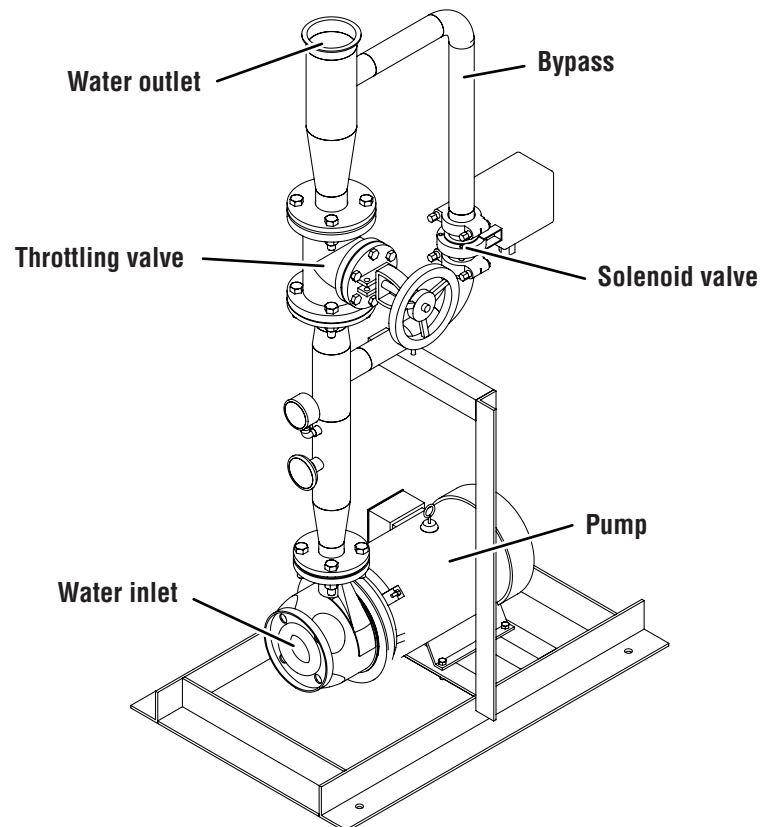

# Storage Tank

## Materials of Construction

Component	Material
Structural layer	Fiber-reinforced plastic
Structural and liner resin	Derakane™ 441-400
Exterior layer resin	Isophthalic polyester
Tank finish	Gel coat with UV inhibitor
Color	Gray (AT071)
Tank fittings	Fiber-reinforced plastic
Vent	Fiber-reinforced plastic
Manhole and cover	Fiber-reinforced plastic
Manhole cover bolts	Stainless steel
Manhole gasket	EPDM
Hold down and lifting lugs	Powder-coated carbon steel

## General Specifications

Design standard	ASTM D49097-00
Maximum pressure	Atmospheric
Vacuum	None
Maximum temperature	180 °F (82.2 °C)
Specific gravity	1.2
Seismic code/design	None
Wind load	0 mph/kph
Immersion heater port	2" NPT
Sight glass port	1" NPT
Insulation thickness	2" (50 mm)

## Specifications by Model

Model	Nominal Storage Volume		No. Inlet Connections	Piping Connections				Height		Diameter		Weight (Empty)	
				Inlet		Outlet							
	Gal	m <sup>3</sup>		in.	mm	in.	mm	in.	mm	in.	mm	lb	kg
RST-1001	1000	3.785	1	2-1/2 NPT	65	2 NPT	50	96	2442	65	1651	1200	544
RST-3001	3000	11.36	1	3 NPT	80	3 Flange	80	148	3759	87	2210	2000	907
RST-5001	5000	18.93	1	4 Flange	100	4 Flange	100	152	3861	113	2870	2600	1179
RST-5002	5000	18.93	2	4 Flange	100	4 Flange	100	152	3861	113	2870	2600	1179



# Orientation

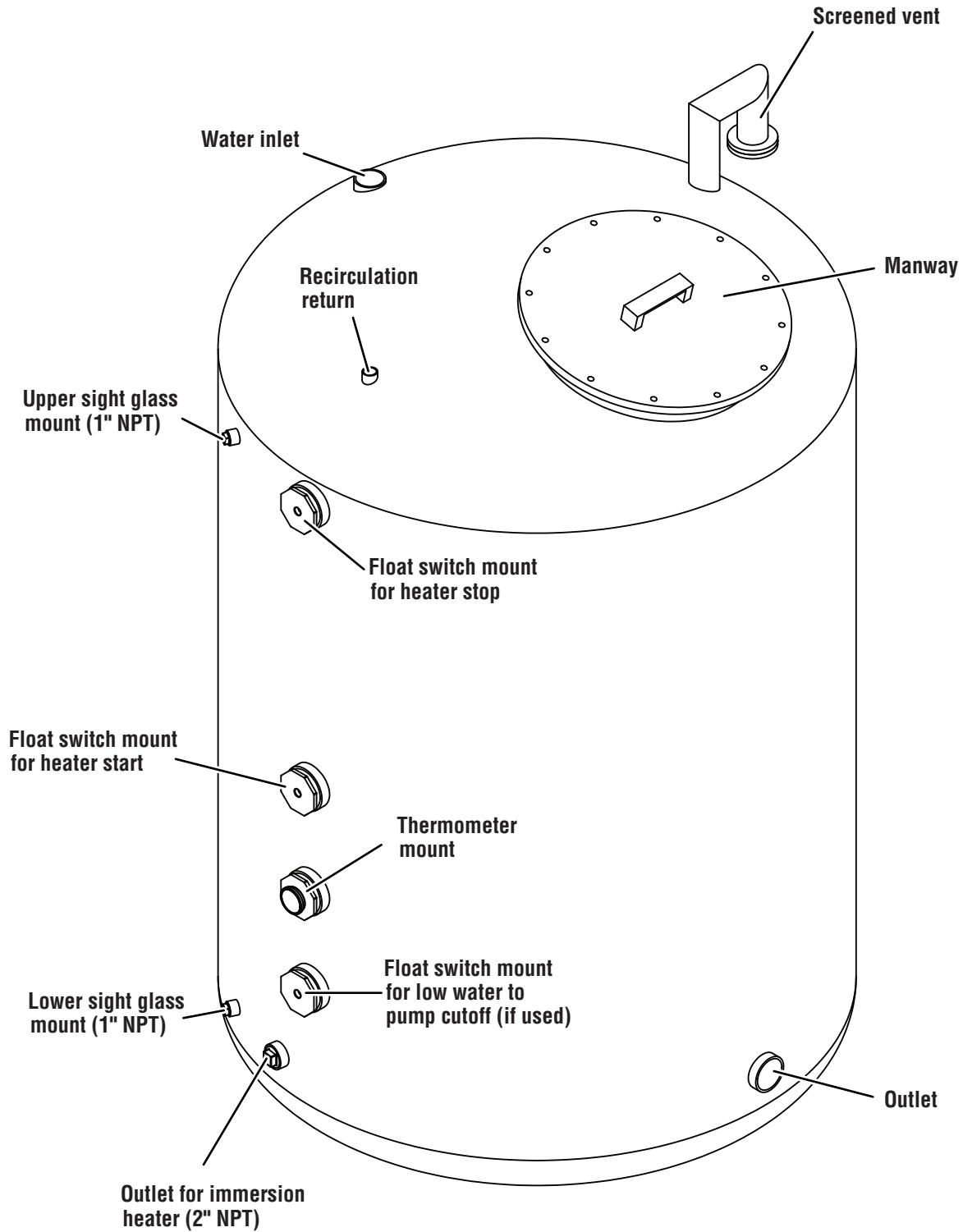

# Assembly and Installation

## Unpacking

### Note:

- Obvious damage should be noted on delivery paperwork. Hidden damage must be reported to carrier within ten days.
- Cleaning heater using local plant standard is recommended prior to installation.
- Storage tanks are typically shipped directly from vendor.

Depending on heater size and mode of shipping, one of two scenarios may apply.

Small heaters (approximately AFD-5000 and under) when shipped with adequate height clearance in vehicle:

- Top plate and upper canister will be attached and upright.
- A fork lift will usually be adequate for moving. Use of a strap or chain is recommended.

Large heaters:

- Top plate will be bolted to lower canister.
- Upper canister will be on its side with top covered.
- A crane or hoist of some kind will be needed for moving. At least two, preferably four straps or chains will be needed.

## Installing Large Heaters

- 1** Stand upper canister upright and position near final heater location.

**Note:** Remove cover and, if necessary, rearrange pulls until they are approximately level and do not interfere with spray nozzles.

- 2** Wipe off flange and place gasket on it with holes aligned.

- 3** Remove cable ties from wiring and unbolt top plate from lower canister.

**Note:** Long bolt in blower motor bracket must be reinstalled in that hole.

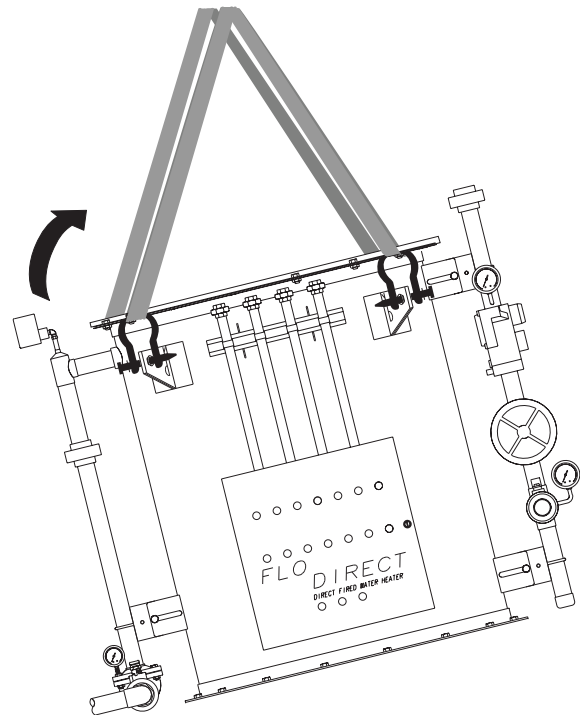

- 4** Remove top plate from lower canister.

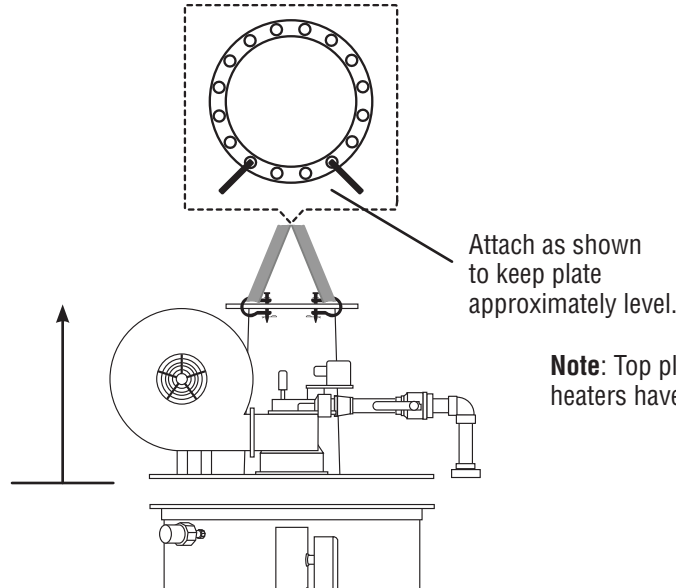

**Note:** Top plates on largest heaters have lifting lugs.

- 5** Position top plate on top of upper canister with holes aligned.

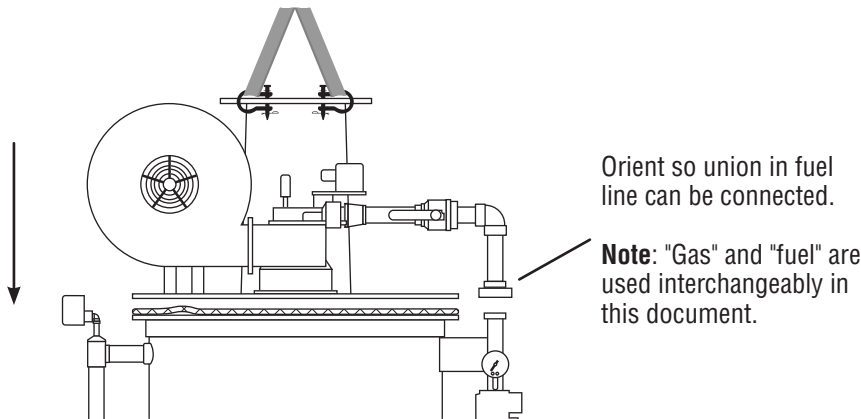

- 6** Install all bolts and start nuts. Liberal use of an anti-sieze compound is strongly recommended.

- 7** Tighten all bolts using pattern shown or similar.

**Note:** This pattern is for heaters with 16 bolts. 24-bolt patterns should be tightened similarly.

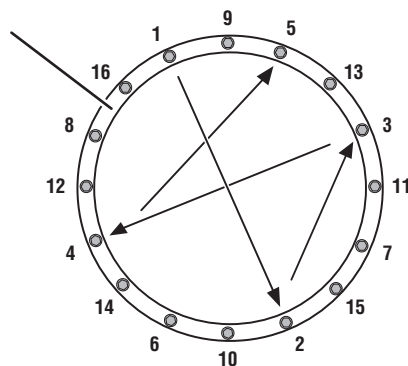

- 8** Attach canister sections as for a small heater below.

# Installing Small Heaters

- 1** Place lower canister in final heater position:
  - On level surface
  - With adequate clearances
  - With adequate support for operating weight
  - With outlet facing transfer pump location
  - Not near flammable or combustible materials

- 2** Wipe flange and gasket to remove any dirt or debris and place gasket on flange of canister with holes aligned.

- 3** Move upper canister into position over lower canister using lift lugs.

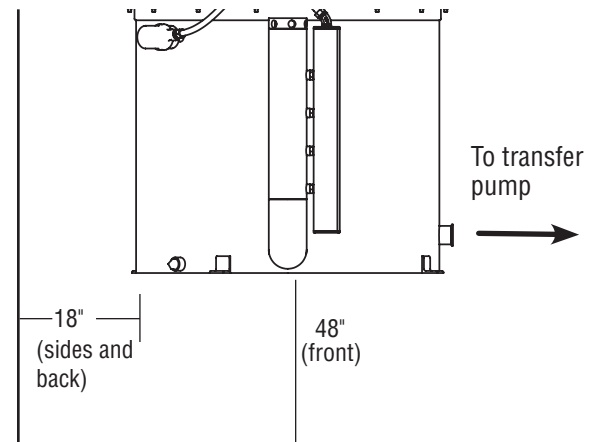
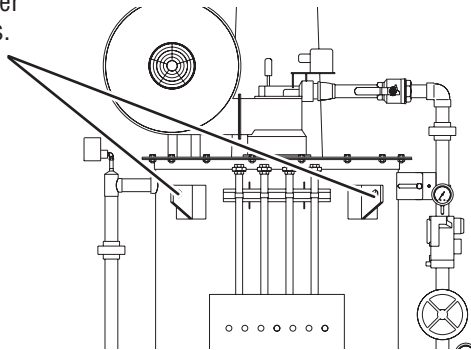

- 4** Lower carefully until a few bolts can be inserted.

**Tip:** Using several tapered pry bars or long screwdrivers will aid in aligning.

**Note:** Control panels are typically above standpipe (see approval drawing for actual orientation). If slight indexing is required to align outlet, some rewiring may be necessary between canister sections.

- 5** Lower upper canister completely, insert all bolts, and start nuts. Liberal application of an anti-sieze compound is strongly recommended.

- 6** Raise entire heater slightly above floor to allow self-aligning.

- 7** Snug all bolts using pattern shown or similar.

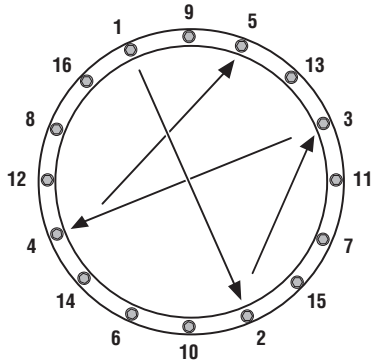

- 8** Lower onto floor and tighten all bolts using pattern shown or similar.

**Note:** Leakage is normal pending stress relief. Tighten applicable bolts as required when leaks appear.

- 9** Armstrong recommends anchoring heater in place.

- 10** Repeat tightening sequence after several hours and after a few days of operation or as leaks occur.



# Installing Exhaust Ducting

**Note:**

- Roof installation preferred.
- Flo-Direct heater is not naturally drafting; exhaust is under slight pressure.
- Insulation is not required because exhaust temperature is only a few degrees above incoming water temperature.

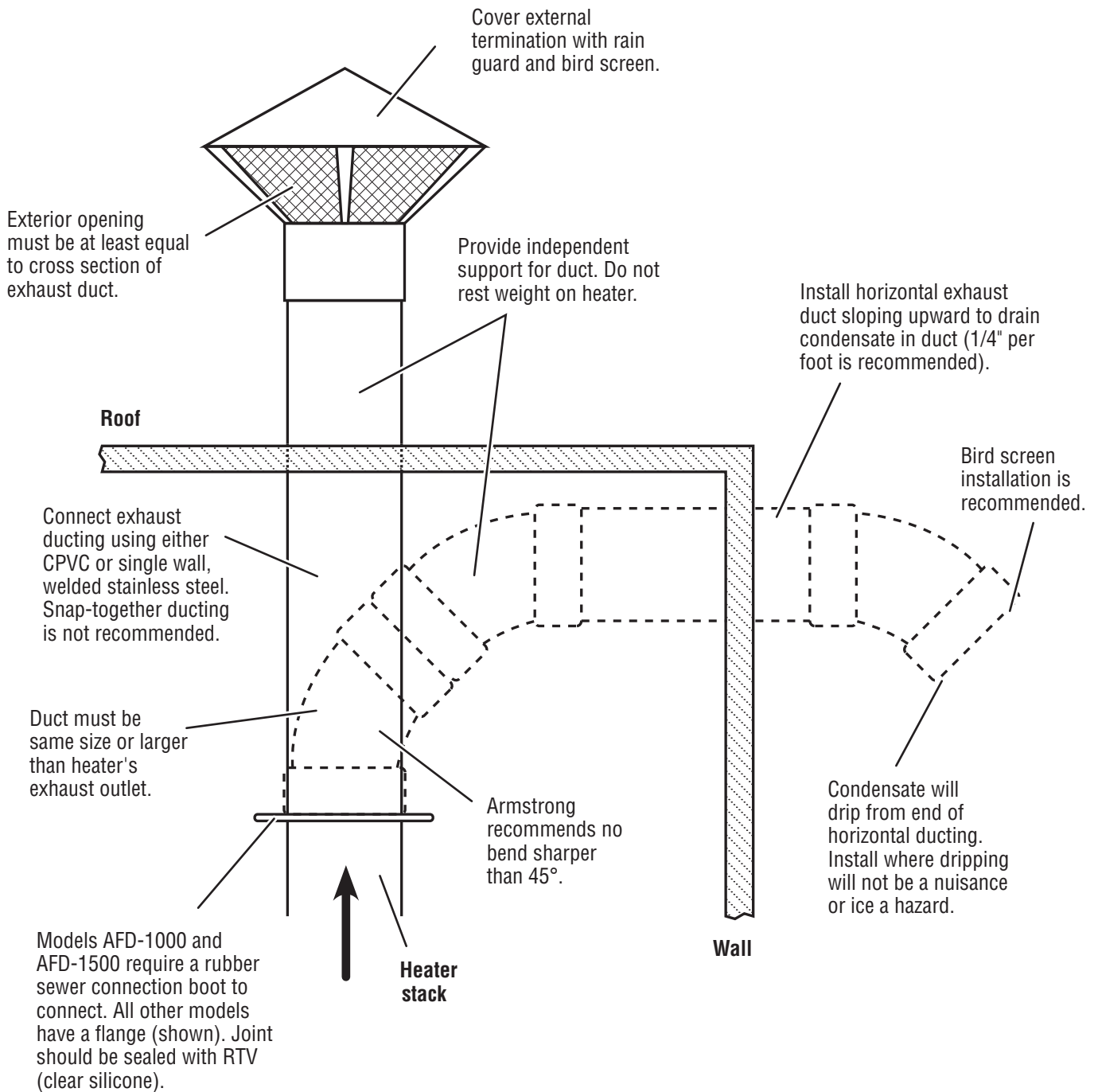

# Installing Intake Air Ducting

**Note:**

**Do not** use manifold connected to other appliances.

**Do not** run heater under negative air pressure.

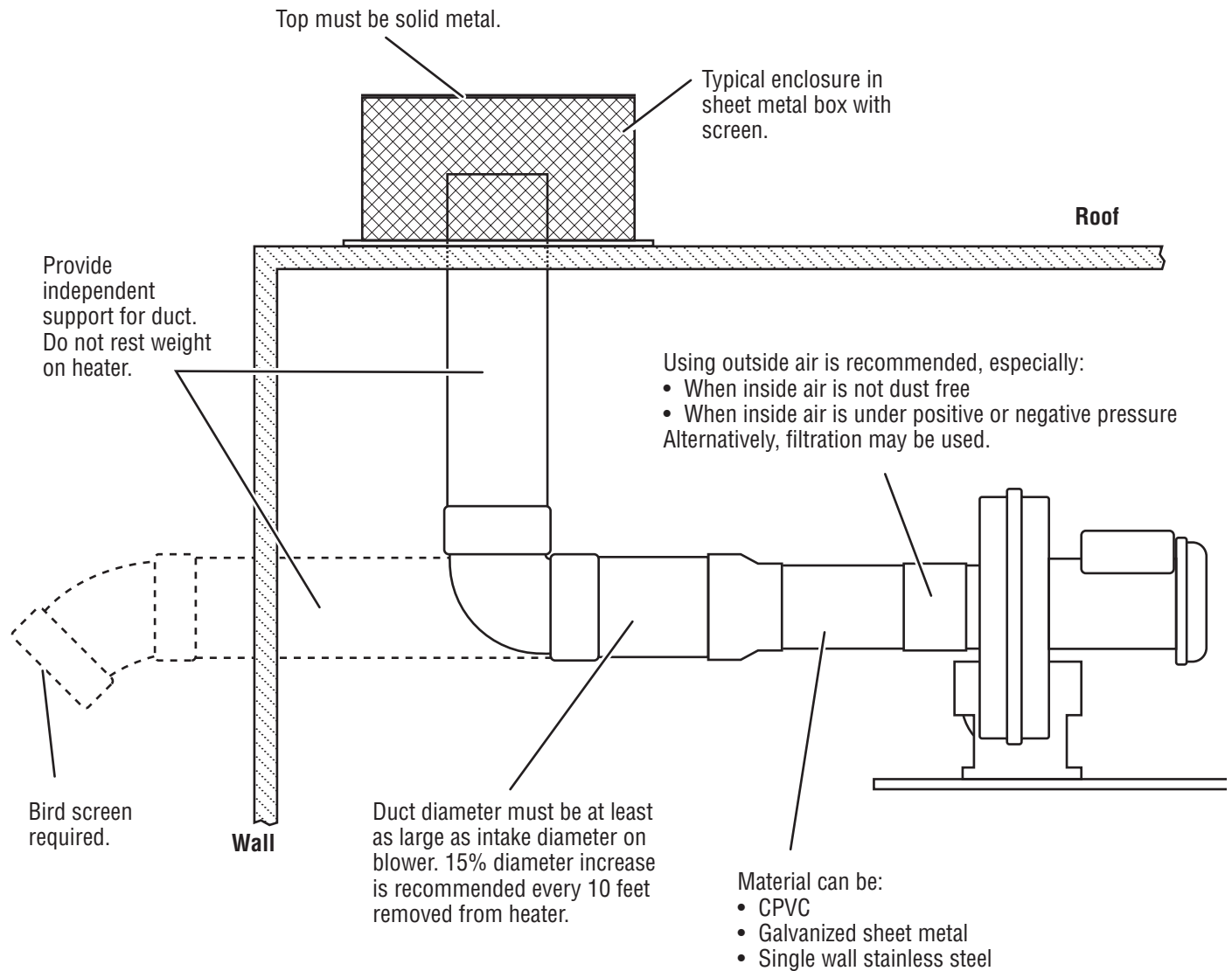

# Water Connections



Warranty is void unless clean, potable water is used.

If large pressure swings occur, install pressure regulating valve in inlet water line.

Inlet water pipe must be at least as large as heater's water inlet piping. Maximum recommended water velocity is 9 ft/sec in inlet piping.

**Note:** Incoming water must not contain any chloride compounds above 50 ppm or salts. These will destroy 304 stainless steel. (Alternative metals are available.)

Line from transfer pump must be routed to top of storage tank to prevent backflow.

Line from transfer pipe must be at least as large as transfer pump pipe.

Storage tank

Suction hose between heater and transfer pump must be flexible to isolate vibration.

Lower canister

Transfer pump assembly must be installed on level surface and at or below heater level to maintain pump's prime.



# Fuel Connection

- 1** Connect union in line between top plate and upper canister.

**Note:** Local codes may require routing regulator vent outside.

- 2** Connect gas supply (applicable codes may govern connection type). Provide adequate support.

**Note:** Do not put excess weight on heater connection.



**Note:** If codes require pressure test of fuel line, close ball valve entering fuel train to heater. Failure to do so may damage fuel regulator.

- 3** With ball valve entering fuel train closed, purge air from fuel line.

# Electrical Panels

## Control Panel

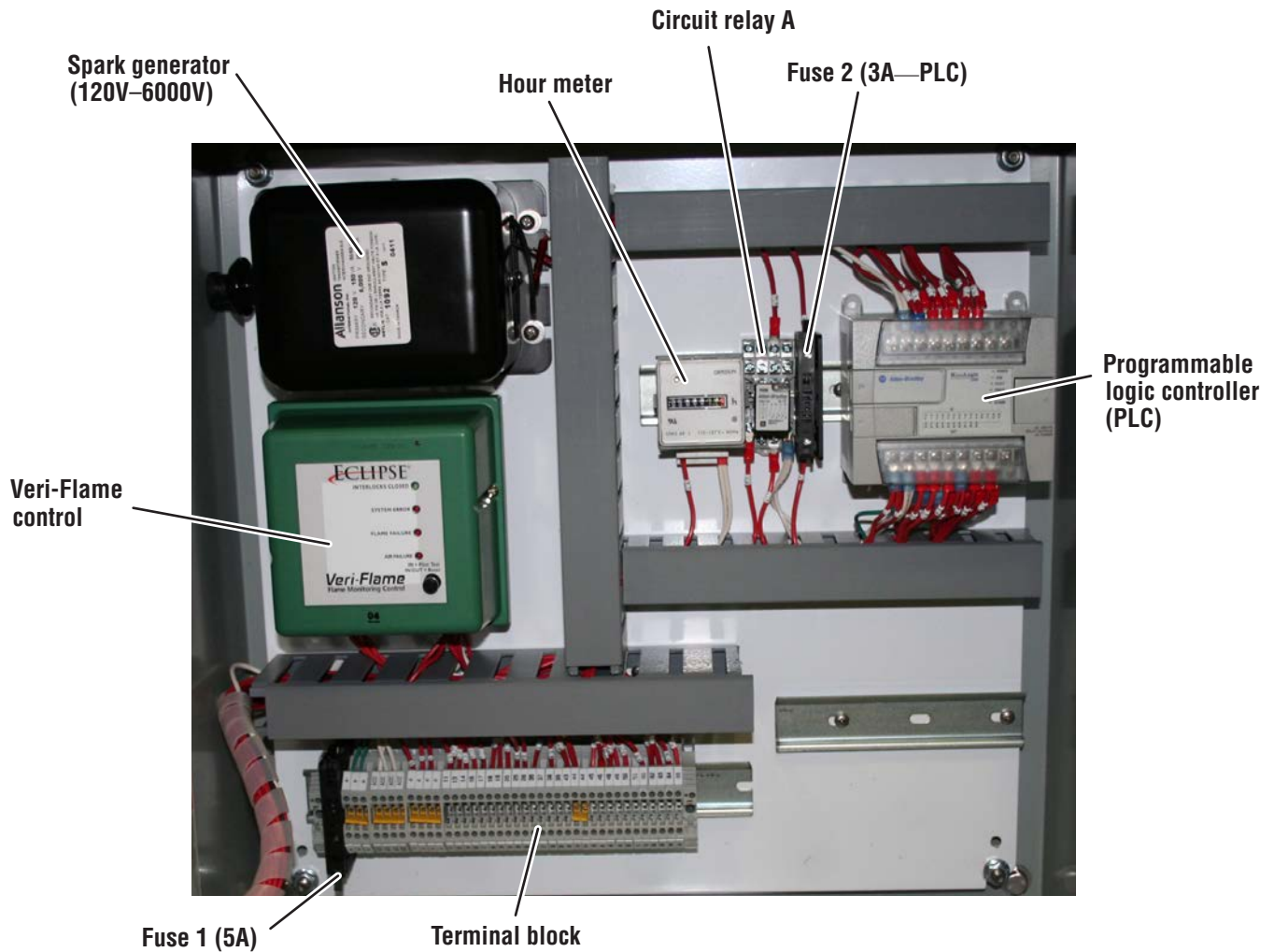

Control Panel Cover (non-modulating)

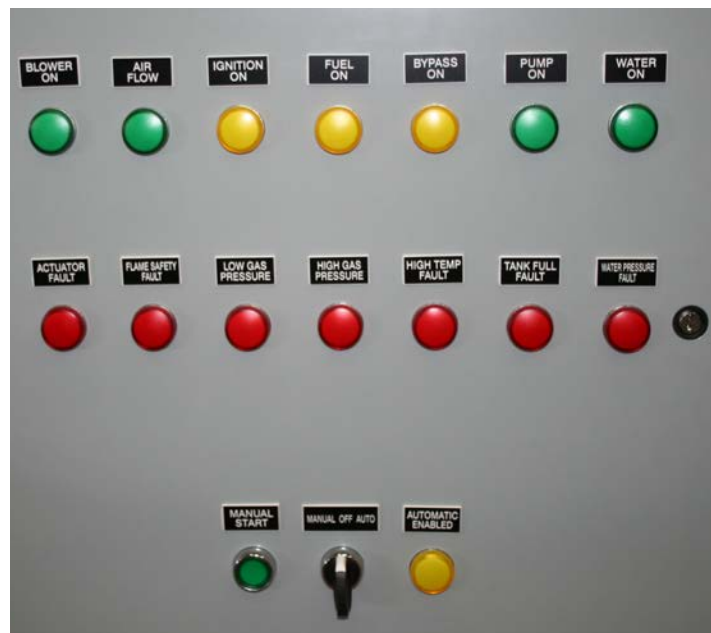

# Disconnect Panel

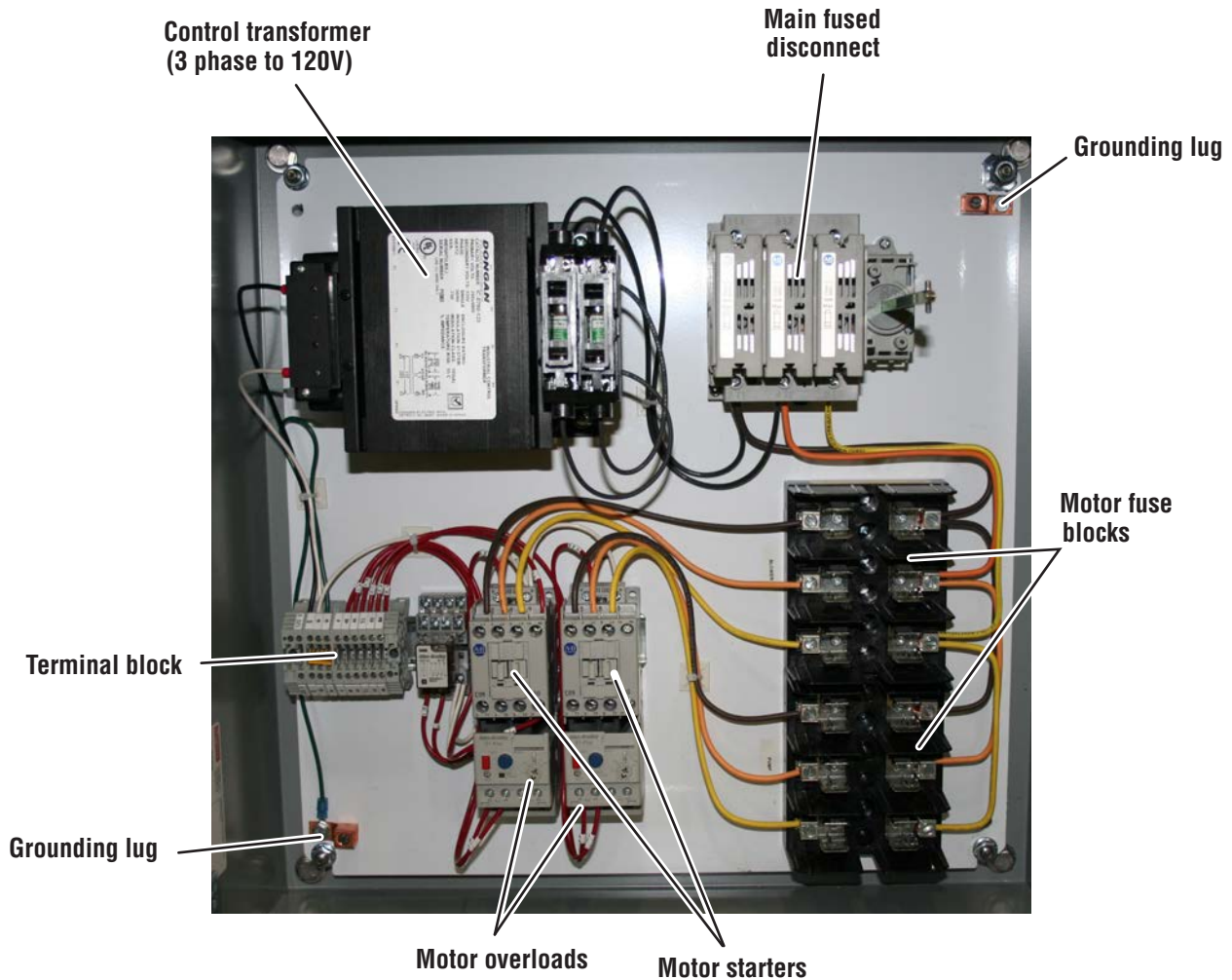

# Heater Label

**Note:** This is a sample label. All electrical work must conform to the specifications on this label as found on your heater.

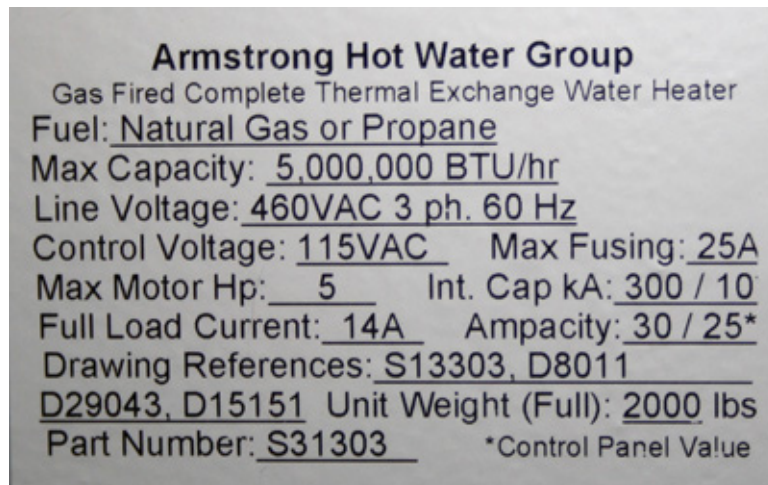

# Electrical Connections

**Note:**

- Consult wiring schematic provided with your heater for exact details.
- Remove all cable ties, bubble wrap, and tape from wiring.

## Top Plate to Upper Canister

**Note:** Sequence shown is recommended, not required.

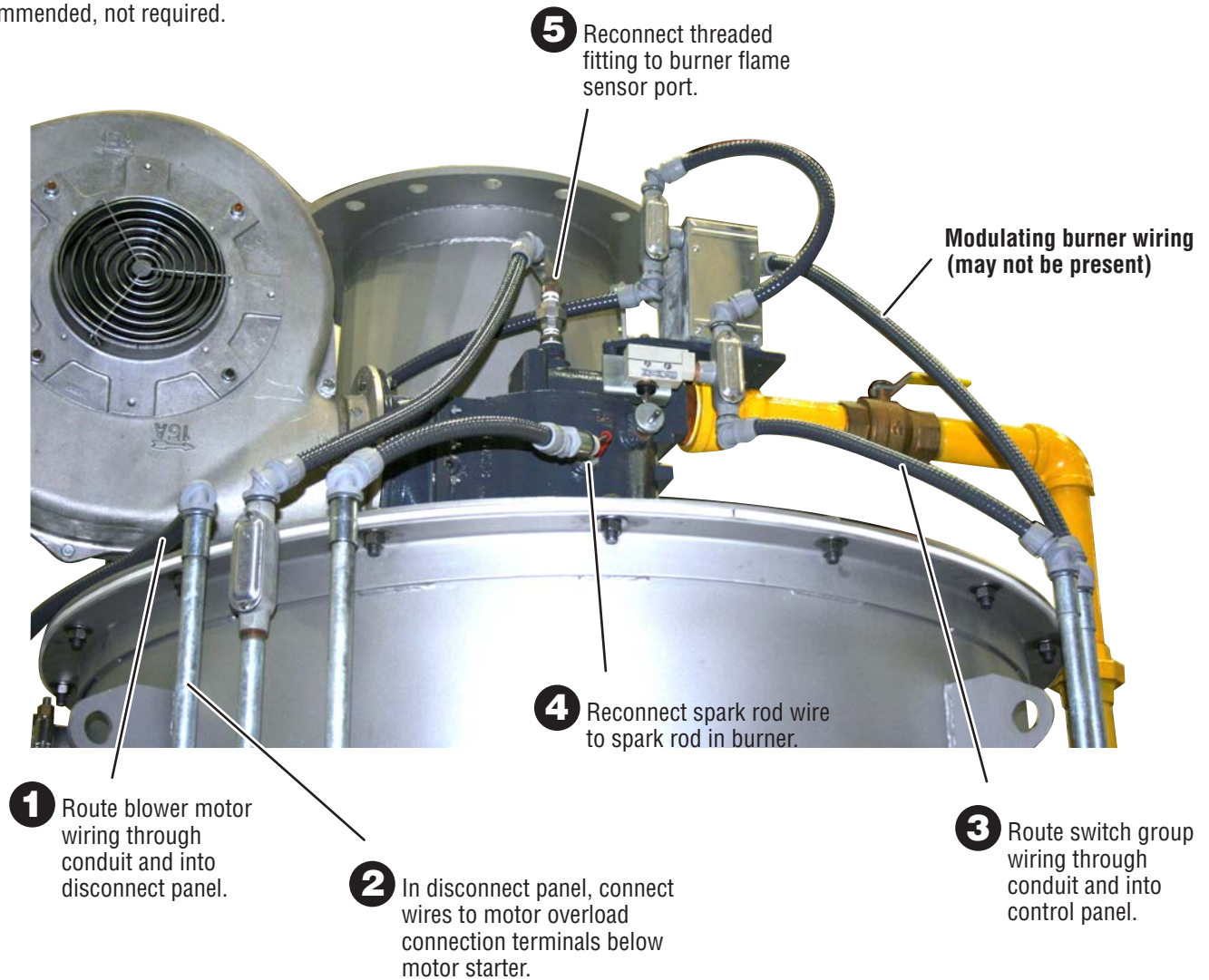

**Note:** Wires are labeled. Confirm labeling of starter by checking for wire labeled 48A below it.

- 6** Reconnect water pressure switch wiring on top plate to water pressure switch on upper canister.



## Upper to Lower Canister

**Note:** Depending on how canister sections were oriented during installation, wires and conduit for these connections may not be the correct length. Rewire if necessary.

- 1** Thread high temperature switch wiring into control panel.
- 2** Reconnect conduit.
- 3** Connect wires to corresponding number locations in terminal block.

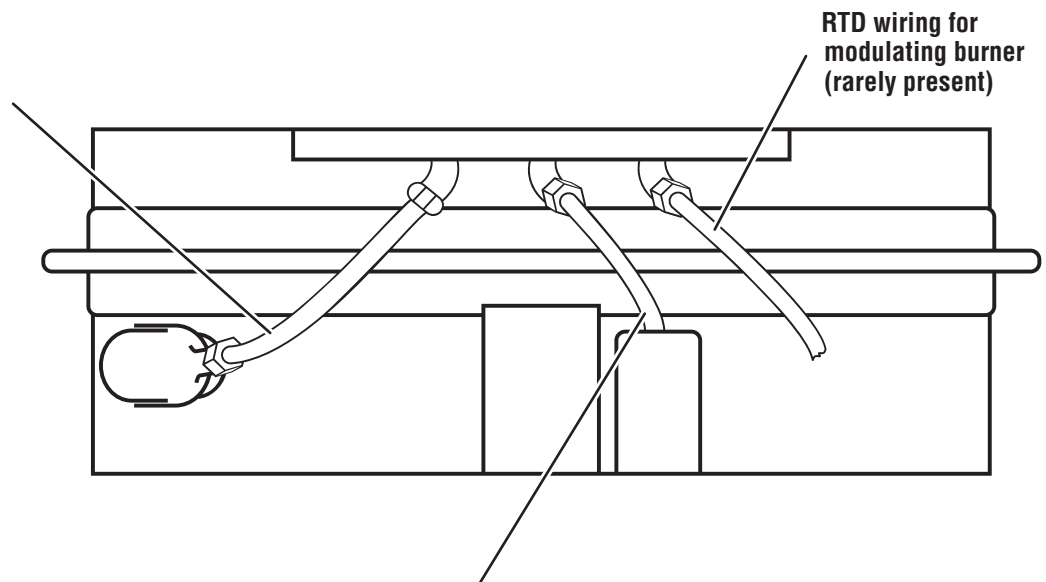

- 4** Repeat for float switch wiring from standpipe.



# Transfer Pump

- 1** Thread wires into control box and reattach conduit.
- 2** Connect motor wires to overload terminal below motor starter with wire colors opposite same color on input side.  
  
**Note:** Confirm location by looking for wire #83A connected to coil of starter.
- 3** Connect numbered wires to corresponding terminals on terminal strip.
- 4** If modulating burner, connect second wire for RTD to control panel.

# Storage Tank

- 1** Install float switches from Armstrong in tank oriented as shown.

- 2** Using additional wire and conduit as necessary, thread wires into control panel on heater.

- 3** Connect numbered wires to corresponding terminals on terminal block.

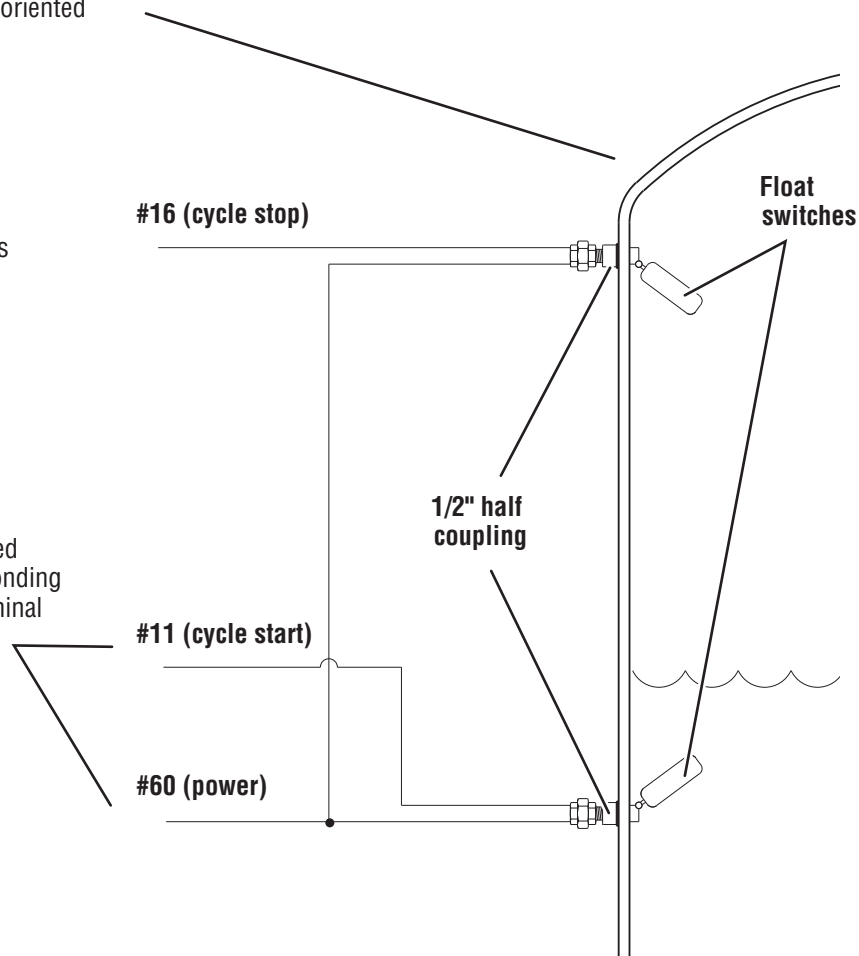

# Main Power Connection

**Note:** If facility does not have surge and lightning protection, Armstrong recommends both for heater.

**1** Connect supply voltage to top terminals of main fuse disconnect inside disconnect panel.

**2** Manually test each starter ("bump the starter") to check for correct motor rotation, as indicated on motor housing.

**Note:** If rotation is incorrect, change any two phases on input side of applicable starter and recheck.

**3** Connect supply ground to grounding lug at top right of disconnect panel.

**4** Tighten all conduit connections.

# Operation

## Description of Operation

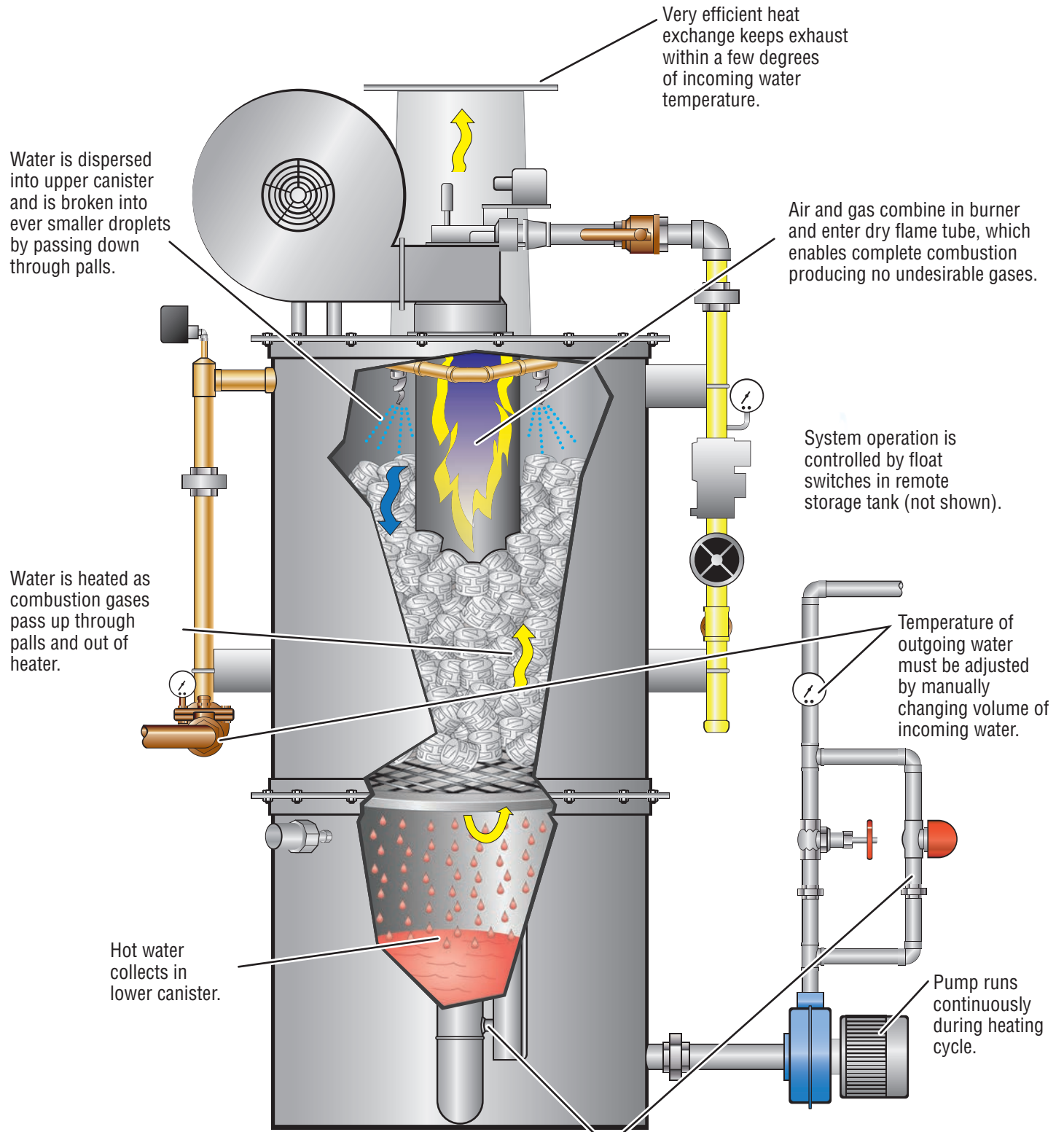

# Sequence of Operation

**Note:** The description in this section assumes that the heater is in automatic mode — "MANUAL/OFF/AUTO" switch set to "AUTO." If heater is equipped with modulating burner, modulation control must display red "MANUAL" when heater is not running or it may not start. **Do not press "MANUAL" on the Powers controller thinking it must match heater's mode!** Once heater starts, Powers controller will switch to auto mode automatically. *Text in italics below is more specific information intended to aid in troubleshooting.*

**1** When low level float switch in remote storage tank calls for water (*Wire #11; PLC input 0 energized*), PLC will confirm that top float switch in lower canister (*wire #20; PLC input 8*) is not in a fault condition and burner is in low fire position (*wire #13; PLC input 2*), then energize control relay A (*PLC output 0 energizes wire #81; control relay contacts close*).

**!** **Note:** PLC is preset. Re-programming it without written permission will void the warranty and absolve Armstrong of all service commitments.

**2** If low gas pressure, high gas pressure, and high temperature switches are all closed (no fault conditions), power will be supplied to Veri-Flame controller (*wire #47; terminal 7 on Veri-Flame—"Interlocks closed" light will come on*). (Any fault condition will cause Veri-Flame control to shut down heater.).

**3** If air pressure switch is open and fuel valve is closed, blower will start ("BLOWER ON" lights; *wire #48; terminal 8 on Veri-Flame*).

**4** Within a few seconds, air pressure switch must indicate adequate pressure ("AIR FLOW" lights), then blower will initiate a 30-second purge (*time is adjustable using DIP settings on Veri-Flame*).

**5** Veri-Flame control allows fuel into burner ("FUEL ON" lights; *Veri-Flame terminals 3 and 4 energize*) and the spark rod to ignite it ("IGNITION ON" lights). Simultaneously water valve opens ("WATER ON" lights).

**6** When UV scanner confirms flame, Veri-Flame control (*wire #45; terminal 5 on Veri-Flame*) energizes actuator:

- Non-modulating burner opens air and fuel dampers, and burner enters high-fire setting.
- Modulating burner control changes from manual to auto mode allowing control to track set point.

**7** Veri-Flame control de-energizes spark rod ("IGNITION ON" off; *wire #44; terminal 4 on Veri-Flame*).

**8** Pump will start ("PUMP ON" lights; *wire #18; PLC input 6*) when water in lower canister reaches second float switch.

**9** During operation when correctly set, transfer pump bypass will cycle on (increasing water flow; "BYPASS ON") and off keeping water level in lower canister between middle float switches.

**10** Once upper level switch in remote storage tank closes (*wire #16; PLC input 4*), PLC will de-energize CR-A causing Veri-Flame control will turn off fuel valves. Blower will run for several seconds to purge any remaining fuel.

**11** If POC switch senses that fuel valve did not close completely, lockout valve will close and blower will come on to purge any fuel.

# Pre-Start-Up Checklist

**Note:** This section to be performed by installer. Consult other information, such as schematics, as necessary.

- Heater in permanent location on level surface sufficient for load and anchored
- Heater assembled
- Transfer pump (if used) in place with flexible water pipe connected
- Wiring reconnected
  - Water pressure switch
  - Blower motor
  - UV scanner
  - Spark rod
  - Burner modulation, if used
  - Lower canister float switches
  - High temperature switch
  - Transfer pump
  - Remote storage tank switches or field-supplied relay coil in control panel
- Fuel line connected
  - Adequately sized
  - Adequately supported
  - Pressure checked if required
  - Purged
- Water piping connected
  - Sufficient inlet flow and pressure
  - Adequately supported
  - PRV if large pressure swings
- Exhaust piping connected
  - CPVC or stainless steel
  - No unsealed joints
  - No bends sharper than 45°
  - Properly sized (no back pressure)
  - Adequately supported
  - Properly terminated
- Intake air piping connected or filters installed if necessary
  - CPVC, stainless steel, or galvanized
  - Adequately sized
  - Adequately supported
  - Proper termination
- Storage tank
  - Properly piped
  - Float switches installed correctly
  - Float switches correctly wired to heater
- Main power supply properly connected
  - Three phase
  - Voltage as specified on nameplate and connections



# Commissioning

---

## Inspecting Installation

- 1 Confirm all checks in start-up checklist above.
- 2 Check all field connections in control panels.
- 3 Identify any additional wiring in panels.
- 4 Confirm rotation of blower and pump motors.
- 5 Confirm what fuel is supplied and note label on fuel train.

## Inspecting Water System

**Note:** Run cold water first to prevent damage in lower canister.

- 1 Jump valve to bypass automatic control.
- 2 Turn "MANUAL/OFF/AUTO" switch on control panel to "MANUAL," but do not press "MANUAL START."
- 3 Set water inlet pressure to about 20 psi.
- 4 Set outlet pressure at pump to 40 psi, with bypass off.
- 5 Visually confirm proper flow.
- 6 Check for leaks.
- 7 Confirm adequate pressure.
- 8 Confirm pump operation.
- 9 Close water valve.
- 10 Set main water valve to normal operation.

## Commissioning

- 1 Turn on fuel.
  - Check for leaks in piping
  - Verify that gas pressure is between 2 and 7 psi

**Note:** Start-up process requires running heater in "MANUAL" mode, which overrides all automation and produces hot water continuously until heater is manually turned off.



Never leave heater unattended in "MANUAL" mode.

- 2 Press "MANUAL START." Verify input zero on PLC lights.

**Note:** During initial start-up, low gas pressure fault light may come on. Once pressure is established, reset pressure switch. Several attempts to start may be required until fuel enters burner.

- 3 Verify that output zero on PLC and relay A light.

- 4 Confirm that Veri-Flame controller has a solid green light.

- 5 Verify that burner goes to high fire after flame is established and Veri-Flame indicates flame.

- 6 Check temperature on gauge above transfer pump. Adjust incoming water pressure to obtain target output temperature if necessary.

- 7 Adjust throttling valve above transfer pump to cycle solenoid (bypass) and maintain water level in heater.

**Note:** Level should fluctuate slowly between second and third float switches without seeing a tank-full fault or pump turning off.

- 8 Check exhaust piping for leaks.

- 9 Insert combustion analyzer in port in exhaust stack and tune heater.
  - Oxygen reading must be 3.5–6%
  - Adjust for minimum carbon monoxide (CO)

**Note:** Low efficiency may be due to back pressure in exhaust piping if opening at cap is too small.

- 10 Record regulator pressure on fuel train label.

- 11 Confirm operation of all safety features:
  - Low gas pressure switch
  - High gas pressure switch
  - Proof of closure switch
  - Low water pressure
  - High temperature
  - Flame failure (UV scanner)
  - False flame

- 12 Perform at least ten start cycles in "MANUAL" mode, allowing heater to reach high fire condition each time, to ensure reliable starting and operation.

- 13 Run heater in "AUTOMATIC" mode to confirm proper operation in that mode.

- 14 Allow heater to sit and cool for several hours, then check for cold start.

# Periodic Maintenance

## Maintenance Schedule

**Note:** Periodic maintenance for blower and burner is **not** shown below. See those IOMs for required maintenance. The Flo-Direct heater is designed to require very little maintenance. The list below is recommended, but only safety items (\*) are required.

Frequency	Task
Daily	Check output temperature (non-modulated). (To change, adjust water flow valve <i>slowly</i> and in small increments allowing time for change to take effect. Increase water flow to decrease temperature and vice versa).
Weekly	Check air filters if present. Clean or replace as necessary (see manufacturer's information).
	Check for water leaks.
Monthly	Check fuel train for leaks.
	Remove and wipe off quartz lens below flame sensor.
	*Check water pressure switch: <ul style="list-style-type: none"> <li>• Turn off water supply while heater is in operation</li> <li>• Confirm that heater shuts down within 10 seconds and "WATER PRESSURE FAULT" light comes on</li> </ul>
	*Check low gas pressure switch: <ul style="list-style-type: none"> <li>• Turn off the fuel supply while heater is in operation</li> <li>• Confirm that heater shuts down and "LOW GAS PRESSURE" fault light comes on</li> </ul>
	*Check high temperature switch (see instructions below).
	Inspect burner's air damper linkage (use a borescope through burner's window).
	Check spark rod connection and wire.
	*Check the Veri-Flame controller: With heater running, close ball valve in fuel train just upstream of burner. <ul style="list-style-type: none"> <li>• Burner should go out</li> <li>• Veri-Flame control should show no indication of flame</li> <li>• Control should de-energize safety shut-off valves (there will be a "clunk" sound as valves close; some models also have indicator lights)</li> </ul>  If results are not as described, a hazard condition exists. Shut down heater and contact Armstrong.
Annually	Check all electrical connections.
	Check all nuts and bolts.
	Check float switches for proper operation.
	Check all fuel train connections and fittings.
	Check all water train connections and fittings.
As Needed (Typically done not less than when warmer is cleaned)	If in a bottling warming application - Perform a Unit Clean In Place (CIP) <ul style="list-style-type: none"> <li>• Dump all bad/dirty water (including in the AFD basin)</li> <li>• Heat up and run Clean in Place               <ul style="list-style-type: none"> <li>◦ Up to facility on chemical additives and duration</li> </ul> </li> <li>• Dump all water again (including in the AFD basin)</li> <li>• Fill with fresh clean water</li> <li>• Run unit</li> </ul>



# High Temperature Switch Check

- 1 With heater on but not running, unscrew cover on switch (shown removed below).



**Caution:** Wiring is live! Avoid touching connections!

- 2 Compress spring to trip switch.

- 3 Confirm that heater shuts down and high temperature fault light comes on. If not, contact Armstrong.

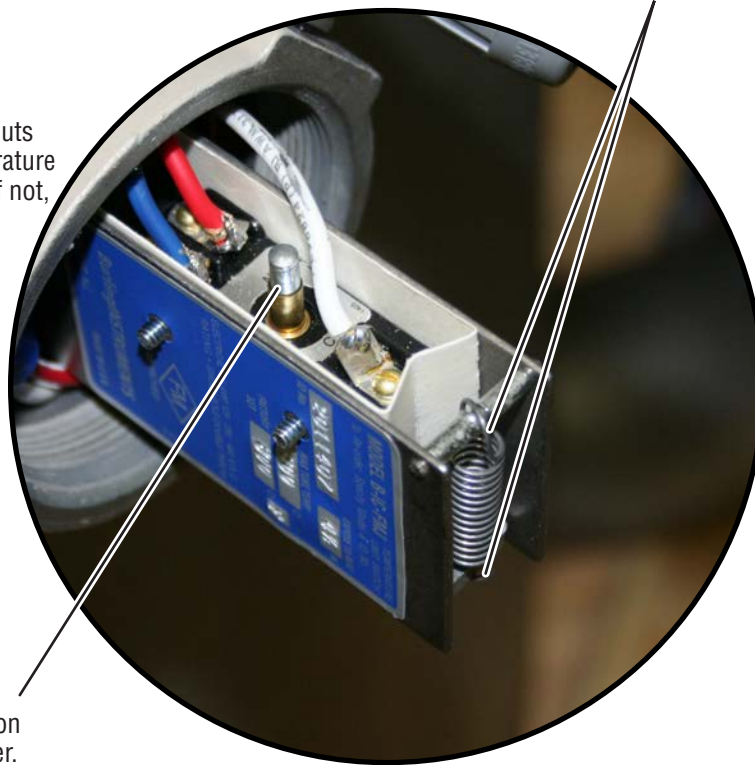

- 4 Press reset button and replace cover.



**Caution:** Wiring is live! Avoid touching connections!

# Troubleshooting

## Troubleshooting Table



**Note:** Turn off power to heater prior to beginning. During troubleshooting, turn it on only when and only for as long as required for specific steps below.

Troubleshooting		
Problem	Probable Cause	Correction
Actuator Fault	Transitory alarm or to confirm fault	Turn "AUTO/OFF/MANUAL" switch to "OFF" then to "AUTO" (or "MANUAL" if using that mode).
	Start attempt without actuator in low fire position	Confirm that switch on burner arm is in contact and closed.
	Heater with modulating burner not in "MANUAL" state at start-up attempt	Press "ACTUATOR RESET" on control panel if it exists. OR Unplug and replug "d-out" relay in control panel.
Flame Safety Fault	Transitory alarm or to confirm fault	Press reset button twice on Veri-Flame controller inside control panel (button must be out). If fault recurs, continue.
	Flame failure	Check spark rod wiring and connection for breaks, arcing, or carbon fouling. Check UV scanner for dirt and reaction to flame.
	Air failure	Check air flow switch: <ul style="list-style-type: none"> <li>• Disconnection</li> <li>• Plugged sensor tube</li> <li>• Defective</li> </ul> Check blower overloads: <ul style="list-style-type: none"> <li>• Electric current setting. Adjust or reset.</li> <li>• If fault recurs, check 3-phase wiring.</li> <li>• If fault persists, check blower motor coil impedance.</li> </ul>
	System error	Check adjustment of POC switch. Check gas valve for proper operation.
Low Gas Pressure	Transitory alarm or to confirm fault	Press red reset button on low gas pressure switch on fuel train.
	Upstream fuel valve closed	Open all upstream valves.
	Defective pressure regulator spring	Replace spring.
	Defective pressure regulator	Replace regulator.
High Gas Pressure	Transitory alarm or to confirm fault	Press red reset button on high gas pressure switch on fuel train.
	Regulator pressure set too high	Turn regulator adjustment screw CCW to reduce pressure.
	Defective pressure regulator spring	Replace spring.
	Defective pressure regulator	Replace regulator.

Troubleshooting		
Problem	Probable Cause	Correction
High Temperature Fault  Contact Armstrong! Do not operate heater!	Water pressure switch failed and "dry fire" start-up attempted	Check water pressure. If correct, replace pressure switch. If not, continue.
	Nozzles clogged	Remove top plate and clean nozzles.
Tank Full Fault: Pump not keeping up with water production	Transfer pump throttling valve out of adjustment	Readjust valve.
	Transfer pump and/or bypass inoperable	Check and repair or replace.
	Downstream valves closed or restricted	Confirm that all downstream valves are fully open.
Water Pressure Fault	Flow control valve restricted	Open flow control valve.
	Shut-off valve defective	Repair or replace valve.
	Restriction in inlet line	Check filters and piping for obstructions.
	Low system pressure	Correct system pressure.
Modulating burner does not enter automatic mode and track set-point ("MANUAL" stays lit after flame is established)	Reset button on Veri-Flame control is pressed in	Press reset button on Veri-Flame control (button must be in up position).

## PLC I/Os

The following PLC inputs and outputs are shown to facilitate more advanced troubleshooting.

Inputs		Outputs	
0	Momentary start (auto or manual)	0	CR-A on; permission to start heater
1	Spark ignition on	1	Water supply on
2	Actuator in low fire position	2	Transfer pump on
3	Water pressure switch	3	Transfer bypass on
4	Storage tank full (auto stop)	4	Water pressure switch fault
5	Lower canister bottom float switch (transfer pump off)	5	Lower canister full fault
6	Lower canister second float switch (transfer pump on, bypass off)	6	Actuator switch fault
7	Lower canister third float switch (bypass on)	7	General alarm
8	Lower canister float top float switch (tank full fault)		
9	Flame detected (main fuel supply on)		

# Parts Lists

## Top Plate

**Note:** Some wiring in this drawing has been removed for clarity.

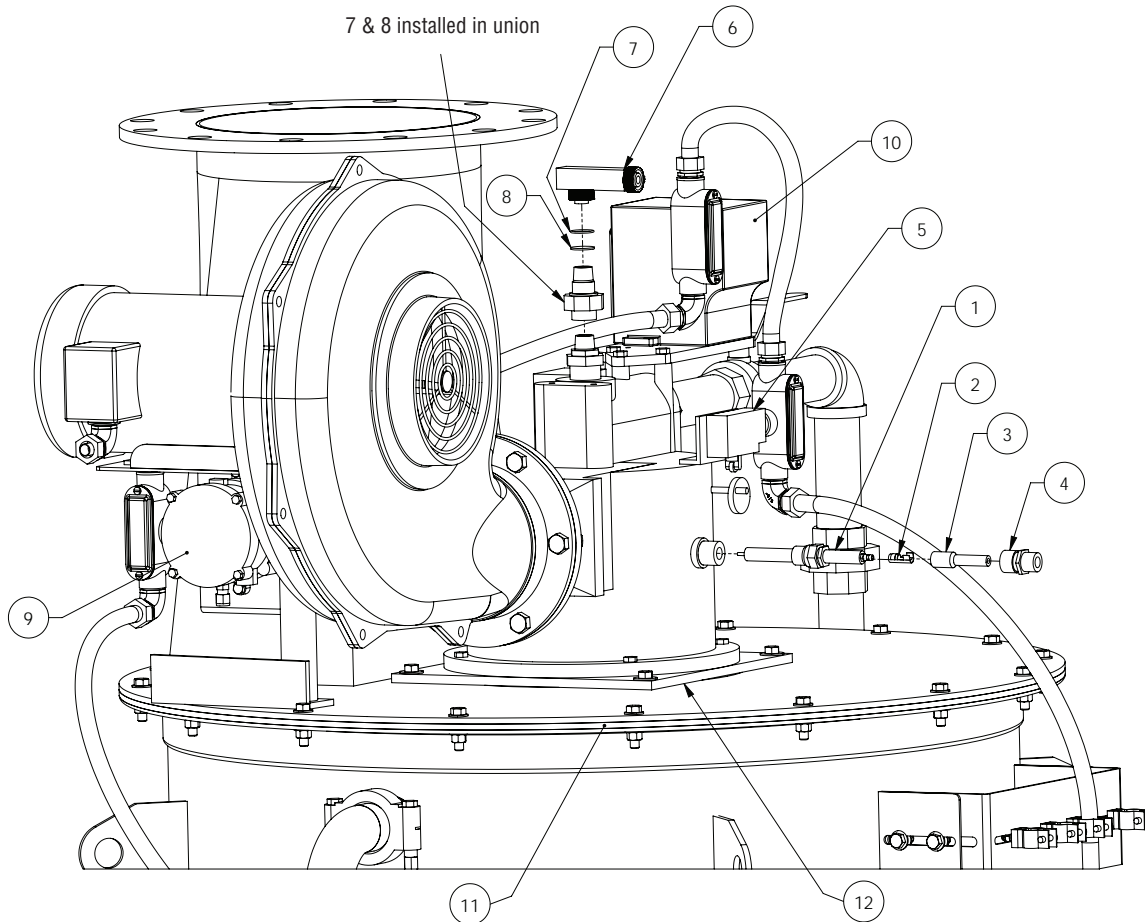

Ref No.	Description	Part No.	Ref No.	Description	Part No.
—	Spark Plug Wire, 7 mm, SCS7-100	D17513	11	Flange Gasket – WARCO White	
1	Spark Rod, #47232	D19194		AFD-1000	D7564
2	Plug End Connector, Strt, ST113	D17386		AFD-1500	D7565
3	Spark Plug Boot, Belden	D27110		AFD-2000	D7566
4	Cord grip, ½", Appleton CG1850	D16992		AFD-3000	D7567
5	Low Fire Limit Switch	D19195		AFD-4000	D7568
6	Veri-Flame, UV Scanner, 90	D16915		AFD-5000	D7569
7	O-Ring, Viton, 7/8" x 1"	D17086		AFD-6000	D7570
8	Quartz lens, 1" Dia x 1/16"	D17085		AFD-7000, 8000	D7571
9	Air Pressure Switch, 1950-5-2F	D16919		AFD-9000 to 12000	D7576
Burner Actuator				AFD-13000 to 16000	D7579
10	Actuator, EMA-405-1, Standard	D16978		Flame Shield	
	Actuator, EMP-424-1, Modulating	D17141		12	AFD-1000 & 1500
			AFD-2000		D27183
			AFD-3000 & 4000		D27184
			AFD-5000 to AFD-16000		D26712

For burner parts, contact MAXON Corp., 765-284-3304 (fax: 765-286-8394)

For blower assembly parts, contact Cincinnati Corp., 513-573-0600 (fax: 513-573-0640)

# Water Train

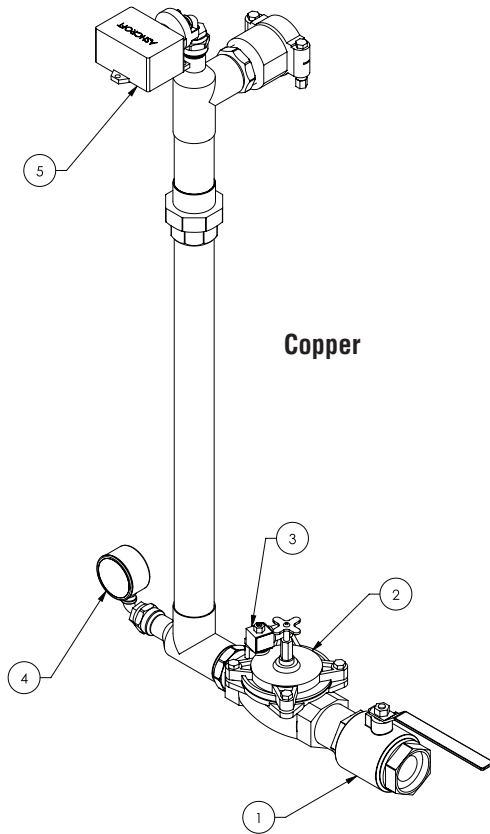

**Copper**

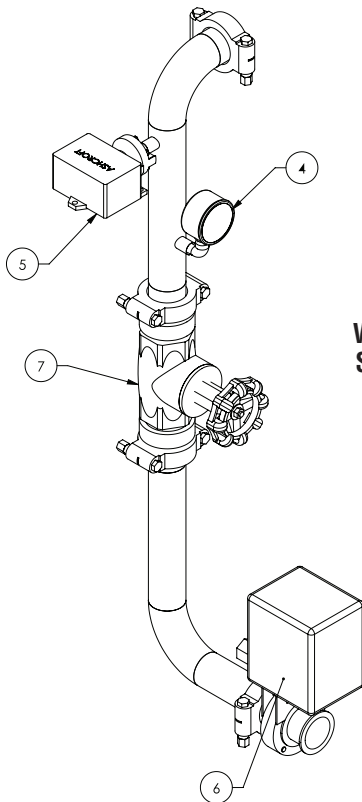

**Welded  
Stainless Steel**

Ref No.	Description	Part No.
Ball Valve - Bronze		
1	1"	D10182
	1-1/2"	D9341
	2"	D10275
	2-1/2"	D18754
	3"	D10184
	4" (Actuated Cast Iron/Carbon Steel Butterfly Valve)	D27041
Weathermatic Valve		
2	1"	D19190
	1-1/2"	D19191
	2"	D18331
	2-1/2"	D18722
	3"	D19192
	4" (Cast Iron/Carbon Steel Globe Valve)	D19193
Weathermatic Valve Diaphragm Assembly		
—	1"	D8655
	1-1/2"	D8656
	2"	D8657
	2-1/2"	D8658
	3"	D8659
3	Solenoid, SOL-7, 110V	D18330
4	Pressure Gauge, 0-110 psi	D11554
5	Water Pressure Switch	D16905
Actuated Butterfly Valve Assembly – Clamp Ends		
6	1"	D14602
	1-1/2"	D14623
	2"	D14624
	2-1/2"	D14625
	3"	D14626
	4"	D14627
	Electric Actuator for Stainless Butterfly Globe Valve, Stainless Steel	D27044
Globe Valve, Stainless Steel		
7	1"	D14596
	1-1/2"	D14597
	2"	D14598
	2-1/2" (flanged)	D14599
	3" (flanged)	D14600
	4" (flanged)	D14601

**Note:** Weathermatic valve may be used on stainless steel train.



# Control Box

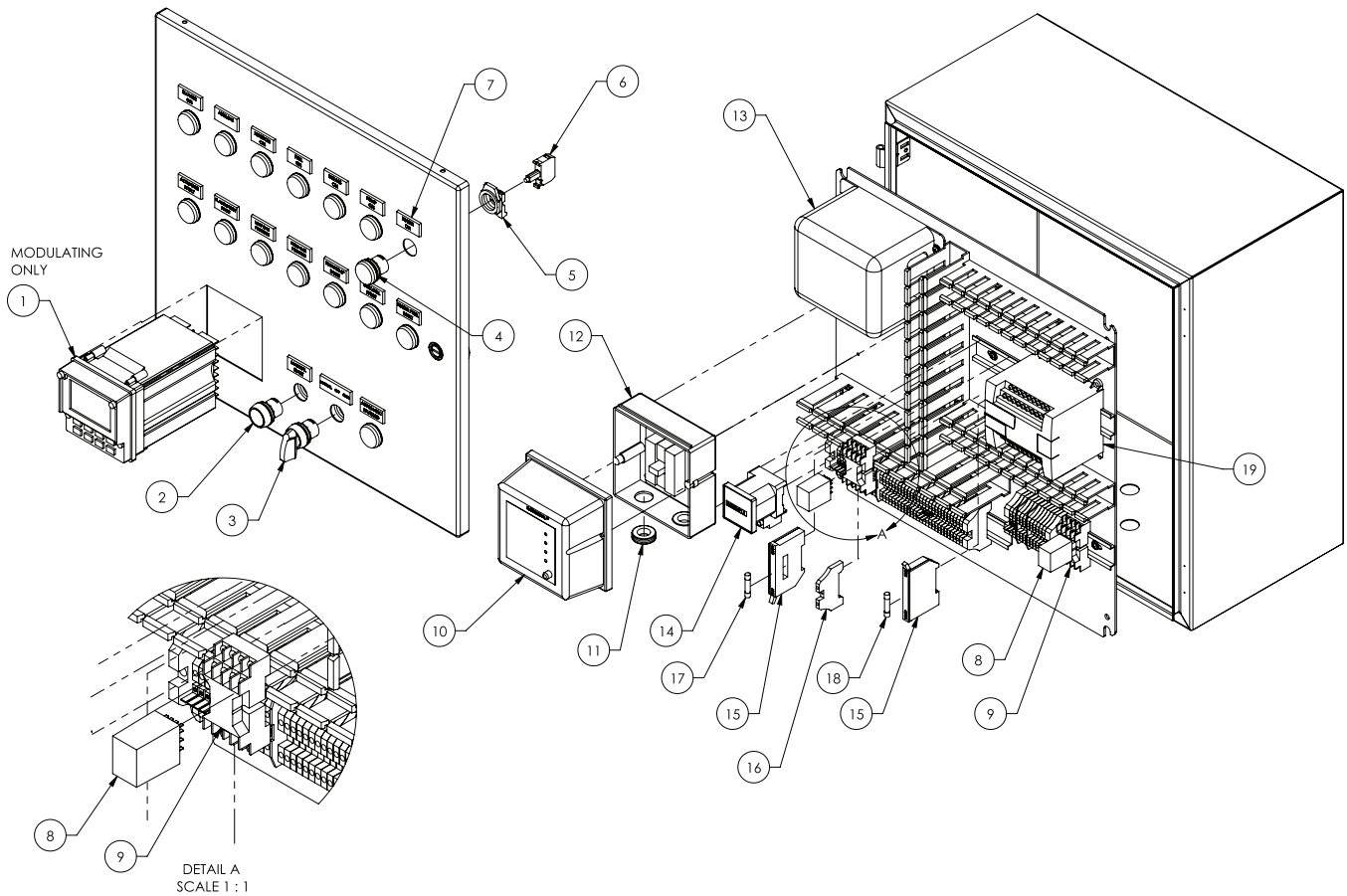

Ref No.	Description	Part No.
1	Powers Controller, 5351112ABD0	D19408
2	Contact, Push Button Operator	D15647
3	Switch, Operator 3-Position	D19152
4	Panel Lens Set (7 Red, 4 Green, 4 Amber)	D8647
5	Latch, Metal, 800FALM AB 800F	D19153
6	LED White for Pilot Light	D47372
7	Control Label set (For All Indicator Lights And Switches)	D19188
8	Relay, 4 Pole, Double Throw	D16903
9	Base Socket, Mini, 14 Blade	D16886
<b>Flame Safety Module</b>		
10	Eclipse Veri-Flame 5605-22 (US)	D19186
	Eclipse Veri-Flame CSA 5605-22AA (Canada)	D19187
11	Grommet, 7/8" ID	D19554
12	Base Terminal Veri-Flame	D19332
13	Ignition Transformer 120/6000	D19185
14	Hour Meter UWZ 48V	D19184
15	Fuse Block	D10787
<b>Circuit Block, IEC, Single Feed</b>		
16	Gray	D10789
	Blue	D6058
17	Fuse, AGC 5A	D19587
18	Fuse, AGC 3A	D19586
<b>Programmable Logic Controller (PLC) AFD Program Loaded</b>		
19	Allen Bradley Micrologix 1200	D19106
	Allen Bradley Micrologix 1100 (Requires Output Module 1762-OW8)	D22729
	Allen Bradley PLC, Output Module, 1762-OW8	D22730



# Disconnect Box

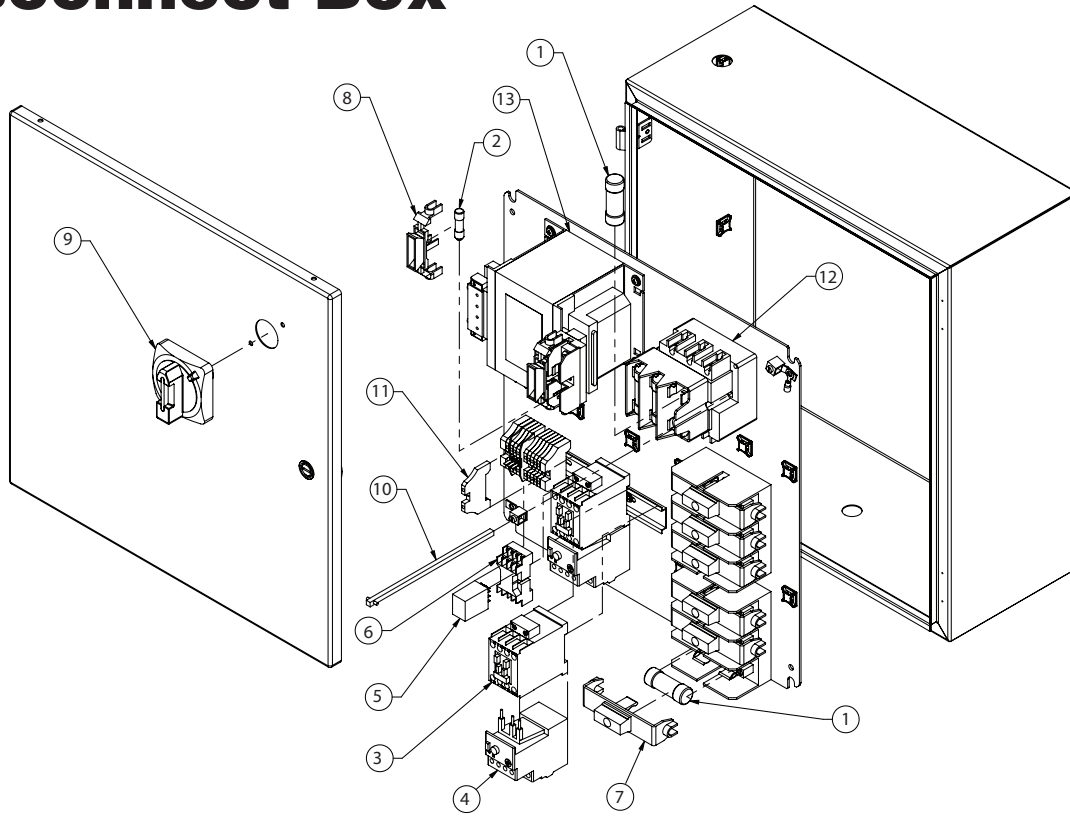

Ref No.	Description	Part No.	Ref No.	Description	Part No.
Fuse, Low Peak, Class J			Motor Overload		
1	3A	D19610	4	1.6-5A	D17910
	5A	D17885		3.2-16A	D7663
	7A	D19611		5.4-27A	D7664
	10A	D19612		9-45A	D7665
	12A	D19613	5	Relay, 4 Pole, Double Throw	D16903
	15A	D19614	6	Base Socket, Mini, 14 Blade	D16886
	17 1/2A	D19615	Fuse Cover, Bus, Indicating		
	20A	D19616	7	30A	D19762
	25A	D19617		60A	D22629
	30A	D19618		100A	D21900
	35A	D19619	8	Fuse Cover, Bus, Non-Indicating	D17413
	40A	D19620	Disconnect Handle		
	50A	D19621	9	30A & 60A	D15638
	60A	D19622		100A	D21901
	70A	D19623	Connecting Rod, Disconnect		
	80A	D19624	10	30A & 60A	D17218
100A	D19625	100A		D21902	
Fuse, Class CC, FNQ-R			11	Circuit Block, IEC, Single Feed	D10789
2	6A	D21849	Fused Disconnect		
	8A	D19763	12	30A	D17179
	15A	D18692		60A	D19671
Motor Starter				100A	D21903
3	5 HP	D7655	Control Voltage Transformer		
	7 1/2 HP	D7656	13	750VA 480 x 240 - 120	D17409
	10 HP	D7657		750VA 575/380 - 115	D13662
	15 HP	D7658			
	20 HP	D7659			
	25 HP	D7660			
30 HP	D7661				

# Fuel Train

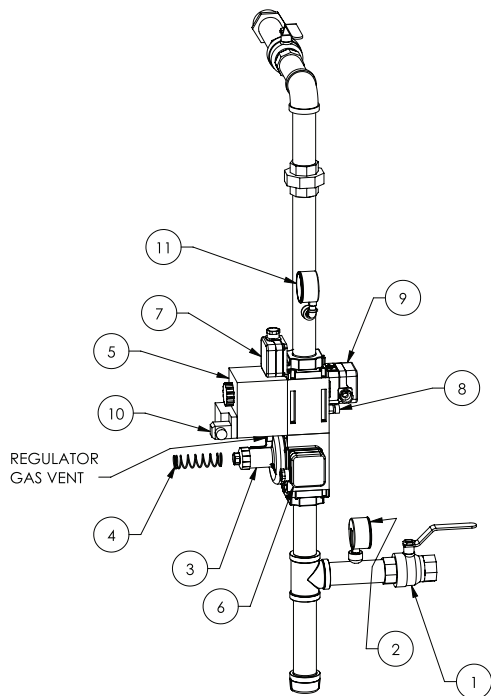
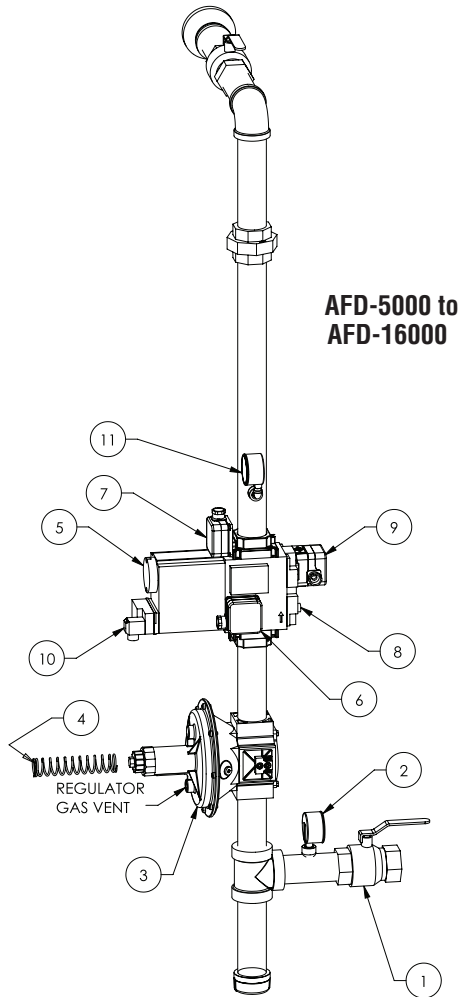

Ref No.	Description	Part No.
<b>Gas Rated Ball Valve</b>		
1	AFD-1000 and AFD-1500 (1" NPT)	D15432
	AFD-2000 and AFD-3000 (1-1/2" NPT)	D15433
	AFD-4000 to AFD-10000 (2" NPT)	D15434
	AFD-11000 to AFD-16000 (3" NPT)	D15435
2	Pressure Gauge, 0-15 psi	D14800
<b>Gas Pressure Regulator</b>		
3	AFD-1000 to AFD-4000 (FRI 710/6)	D14806
	AFD-5000 to AFD-10000 (FRS 720/6)	D14807
	AFD-11000 to AFD-16000 (FRS 730/6)	D14808
<b>Gas Regulator Spring</b>		
4	AFD-1000 to AFD-4000 Yellow 12"-28" w.c.	D11555
	AFD-1000 to AFD-4000 Black 24"-44" w.c.	D14809
	AFD-5000 to AFD-10000 Yellow 12"-28" w.c.	D19189
	AFD-5000 to AFD-10000 Black 24"-44" w.c.	D14810
	AFD-5000 to AFD-10000 Pink 40"-60" w.c.	D12543
	AFD-11000 to AFD-16000 Yellow 12"-28" w.c.	D11559
	AFD-11000 to AFD-16000 Black 24"-44" w.c.	D14811
	AFD-11000 to AFD-16000 Pink 40"-60" w.c.	D12336
AFD-11000 to AFD-16000 Gray 56"-80" w.c.	D12142	
<b>Dual Blocking Valve Assembly</b>		
5	AFD-1000 to AFD-4000 (DMV-D 703/11)	D14823
	AFD-5000 to AFD-10000 (DMV-D 525/11)	D14824
	AFD-11000 to AFD-16000 (DMV-D 5080/11)	D14825
6	Low Gas Pressure Switch 12"-60" w.c. (GMH-A2-4-6)	D11538
<b>High Gas Pressure Switch</b>		
7	AFD-1000 to AFD-14000 12"-60" w.c. (GMH-A2-4-6)	D14829
	AFD-15000 to AFD-16000 40"-200" w.c. (GMH-A2-4-8)	D12335
8	Visual Proof of Closure Indicator	D11573
9	Electrical Proof of Closure Indicator (CPI-400)	D14826
10	DIN Connector (D210319)	D14827
11	Pressure Gauge, 1"-100" w.c.	D14828





# Lower Canister

**Note:** This drawing is a composite.  
Not all parts are present in every  
heater configuration.

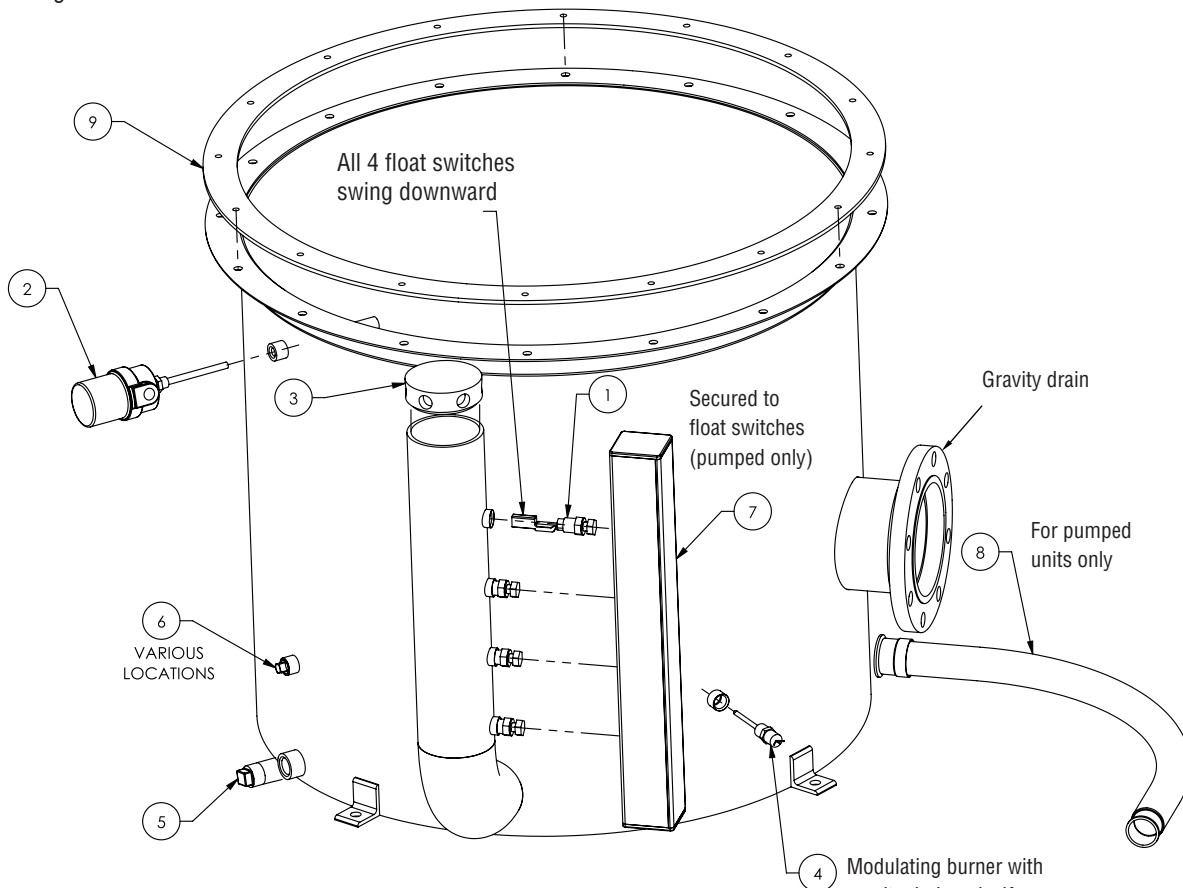

4 Modulating burner with gravity drain only. If pumped, RTD is installed in transfer pump package.

Ref No.	Description	Part No.
1	Float Switch, Polypropylene	D16907
2	High Temp Shutoff Switch, 600 °F	D16916
3	Standpipe Cap	D18110
RTD Temp Sensor		
4	1-1/2", 100Ω	D13273
	2", 100Ω	D10210
	3", 100Ω	D17584
	5", 100Ω	D27358
5	Drain Plug, 1" NPT, 304 SS	D16918
6	Plug, 1/2" NPT, 304 SS	D11018
7	Wiring Trough Drilled for Standpipe	D17265
SS Braided Flex Hose, Clamp Ends		
8	1-1/2" Dia x 36" long	D15722
	2" Dia x 36" long	D15723
	3" Dia x 36" long	D15724
	4" Dia x 36" long	D15725
Flange Gasket – WARCO White		
9	AFD-1000	D7564
	AFD-1500	D7565
	AFD-2000	D7566
	AFD-3000	D7567
	AFD-4000	D7568
	AFD-5000	D7569
	AFD-6000	D7570
	AFD-7000 & 8000	D7571
	AFD-9000 to AFD-12000	D7576
AFD-13000 to AFD-16000	D7579	



# Storage Tank

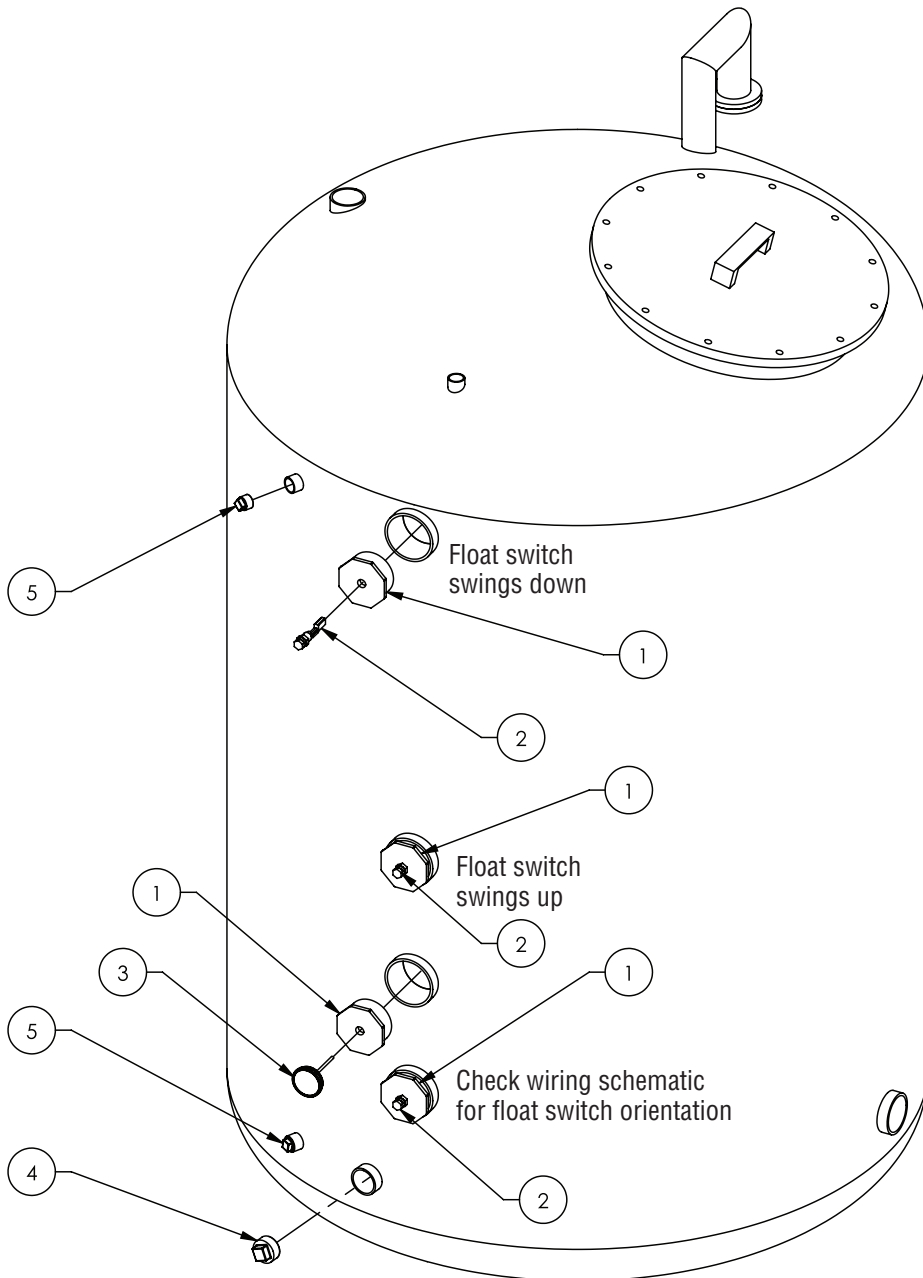

Ref No.	Description	Part No.
1	Bushing, CPVC 4" x 1/2" NPT	D18785
2	Float Switch, Polypropylene	D16907
3	Thermometer, Back Mount, 4" Stem	D8969
4	Plug, 2" NPT, 304 SS	D18789
5	Plug, 1" NPT, 304 SS	D16918

# Appendix: Modulating Burner

**Note:** information on this page is intended for technical personnel.

The standard Flo-Direct uses a powered open, spring-closed actuator. The burner will light on low fire and then go to fully open or the high fire position. The heater's output is only the full rated BTUs of the Flo-Direct. Sometimes it is necessary to vary this output. To accomplish this task, the burner's output can be modulated. The modulating option consists of a 90-degree movement actuator, a programmable controller, and an RTD temperature sensor. The burner's firing rate is changed by the actuator moving a control arm on the burner that is mechanically linked to both an air and a fuel butterfly damper. The burner will still light on low fire, but after the flame is established, the controller will open and close the burner's damper so as to track the set point. If the output is less than the set point, the controller will open the actuator until the output matches the desired set point. When the Flo-Direct's flame is shut off, the controller will go into manual mode and 0% output, ready to start again.

## Descriptions of Major Modulation Components

**RTD:** The temperature sensor is a Resistance Temperature Detector. This is a 100-ohm, DIN curve, three-wire device. The sensor is usually mounted in the outgoing water, either in the transfer pump's piping or the lower canister assembly.



**Actuator:** The actuator is a bidirectional motor that has 90 degrees of arm movement. The motor will drive the arm either clockwise or counter clockwise depending on the position desired by the controller. A "dry" contact in the controller will close to drive the actuator one way, another "dry" contact will drive the controller the opposite direction. The position of the actuator is sent back to the controller via a slidewire. This slidewire is a 100-ohm potentiometer with a wiper arm that will vary from 2-3 ohms to slightly over 100 ohms. If, for example, the controller desires a 50% open actuator, a contact will close to drive the motor one way until the resistance is equal between the wiper arm and the fully open and fully closed resistance. Once the resistance is even, the "dry" contacts will open, leaving the actuator in the 50% position.



Controller: The controller is a Powers 535-1112ABD000 model. This is a fully programmable controller that must be programmed in order to work with the Flo-Direct. These are all pre-programmed and tested before leaving the factory, however, if a replacement controller is installed, the new will have to be programmed as specified in the documentation sent with the Flo-Direct.

This controller has three “dry” contacts and a 4-20 mA DC output, two of the “dry” contacts are to drive the actuator one way or the other, a spare “dry” contact is available for use as an alarm, etc. A 4-20 mA DC output is available to transmit various analog values such as set point, process variable, etc.

The input is set via internal jumpers for an RTD. In addition, there are five special contacts that can cause the controller to perform various functions. The designated output (“d-out”) function is always used. When this “dry” contact is closed, the controller will go to manual mode and 0% output. The controller must be in this mode and output in order for the Flo-Direct to start. Other special functions are possibly as a second set-point and possibly the ability to accept a remote set-point. Please refer to the specific program listing, electrical schematic, and the Powers manual for more detail.

## Operation:

The operator should not have to do anything during normal operation of a modulating Flo-Direct except change the set-point.

NOTE 1: The operating modes of the heater and Powers controller (modulation) are independent. When the heater is in "AUTO" mode, the Powers controller must be in manual mode when the heater is not running; once flame is established, it will switch to auto mode. When the heater turns off, it will switch back to manual mode. **Do not adjust the "MANUAL" button on the Powers controller.**

*Heater in "AUTO" mode  
not running*

*Heater in "AUTO" mode  
running*



Powers controller must be in "MANUAL" mode.



Heater in "AUTO" mode

If the button is pushed, then the controller will try to open the burner to track the set point, but since there is no flame, the controller will drive the burner to the fully open position. Then the unit will not light because the burner is not in the starting (low fire) position. To restore the controller to normal, the circuit for the d-out must be opened and reclosed. On some Flo-Directs there is a button on the panel for actuator reset; on others the relay in the control box must be unplugged and re-plugged (opening and reclosing) the d-out circuit. All of the above can be avoided if the controller is not taken out of "MANUAL" and not switched to "AUTO" when the flame is off. Leave the "MANUAL" button alone.

**NOTE 2:** If the heater is running and the controller does not switch from manual to auto mode and begin tracking the set point (red "MANUAL" light is lit long after the flame is on), then the Veri-Flame controller (green flame safety inside of control panel) has been improperly reset. The reset button must be in the "out" position. If this button is pushed once and not twice, then the Powers Controller will not be released to go to high fire.

For additional information please see the Powers Controller program listing, the electrical schematic, and the Powers Controller manual.



# Limited Warranty and Remedy

---

Armstrong Hot Water, Inc. ("Armstrong") warrants to the original user of those products supplied by it and used in the service and in the manner for which they are intended, that such products shall be free from defects in material and workmanship for a period of one (1) year from the date of installation, but not longer than 15 months from the date of shipment from the factory [unless a special warranty period applies, as listed below]. This warranty does not extend to any product that has been subject to misuse, neglect, or alteration after shipment from the Armstrong factory. Except as may be expressly provided in a written agreement between Armstrong and the user, which is signed by both parties, Armstrong DOES NOT MAKE ANY OTHER REPRESENTATIONS OR WARRANTIES, EXPRESS OR IMPLIED, INCLUDING, BUT NOT LIMITED TO, ANY IMPLIED WARRANTY OF MERCHANTABILITY OR ANY IMPLIED WARRANTY OF FITNESS FOR A PARTICULAR PURPOSE. The sole and exclusive remedy with respect to the above limited warranty or with respect to any other claim relating to the products or to defects or any condition or use of the products supplied by Armstrong, however caused, and whether such claim is based upon warranty, contract, negligence, strict liability, or any other basis or theory, is limited to Armstrong's repair or replacement of the part or product, excluding any labor or any other cost to remove or install said part or product, or, at Armstrong's option, to repayment of the purchase price. As a condition of enforcing any rights or remedies relating to Armstrong products, notice of any warranty or other claim relating to the products must be given in writing to Armstrong: (i) within 30 days of last day of the applicable warranty period, or (ii) within 30 days of the date of the manifestation of the condition or occurrence giving rise to the claim, whichever is earlier. IN NO EVENT SHALL ARMSTRONG BE LIABLE FOR SPECIAL, DIRECT, INDIRECT, INCIDENTAL OR CONSEQUENTIAL DAMAGES, INCLUDING, BUT NOT LIMITED TO, LOSS OF USE OR PROFITS OR INTERRUPTION OF BUSINESS. The Limited Warranty and Remedy terms herein apply notwithstanding any contrary terms in any purchase order or form submitted or issued by any user, purchaser, or third party and all such contrary terms shall be deemed rejected by Armstrong.

Special Warranty Periods are as follows:

- The stainless steel structure and stainless steel internals (flame tube, pall rings, supports, etc.): Seven (7) years from the date of installation, but not longer than eighty seven (87) months from the date of shipment, provided only clean potable water is heated and commercially available fuel is used as well as clean air.
- In applications such as bottle or can warming, special consideration must be placed on routine and preventative maintenance to ensure clean water is used throughout the operation of the unit. Any failures as a result of dirty water will void the warranty.
- The other components on the Flo-Direct, such as valves, combustion equipment, electrical controls, and the burner: Two (2) years from the date of installation, but not longer than twenty-six (26) months from the date of shipment.



# Notes

---

