

DIMENSIONS & DATA CERTIFIED FOR:

Representative:

Order:

Customer:

Order:

Project:

Requirements:

By:

Date:

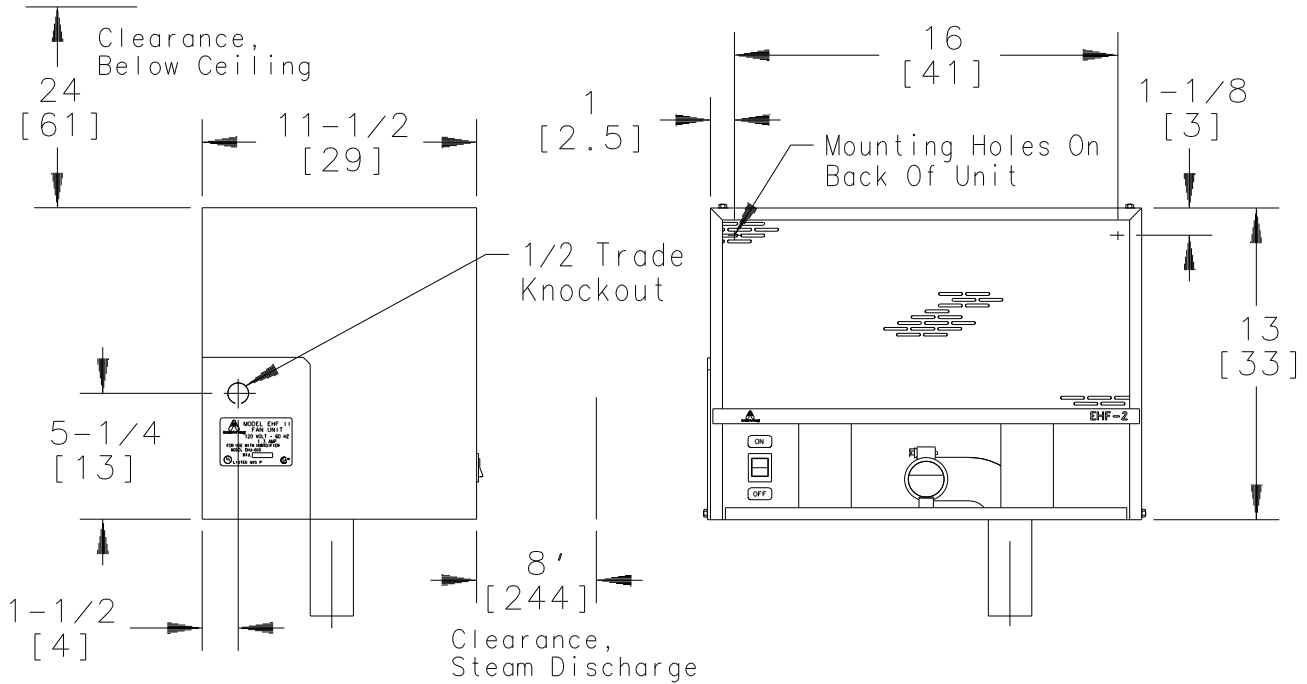

Dimensions in inches [cm] unless otherwise shown.

DESCRIPTION	MODEL EHF-2
Integral Mount	On EHU-701
Capacity, Maximum	30 lbs[14kg]/hr
Hose, Inlet Conn.	1-1/2" ID
Fan CFM	280 CFM
Voltage, Fan 1 ϕ	120 vac *
Amperage, Fan	1.3 amp
Switch	Integral
Weight, lbs[kg]	33[15]

MATERIAL LIST	
Part Name	Material
Cabinet	18 Ga. Steel (Epoxy Enamel Coating)
Tube, Steam Dispersion	T304 Stainless Steel
Hose, Inlet Steam	EPDM

* EHF-2 Fan Package Requires Separate 120 vac Power Supply.



Armstrong International, Inc.
Three Rivers Division
Three Rivers, MI 49093

Armstrong (269) 273-1415 Fax(269) 273-9500
Posted on Armstrong's homepage www.armstrong-intl.com

Product	CD No.	Date
HUMIDIFIER, FAN PACKAGE EHF-2	1084	11/25/03
		Rev. B