

# DIMENSIONS & DATA CERTIFIED FOR:

Representative:

Order:

Customer:

Order:

Project:

Requirements:

By:

Date:

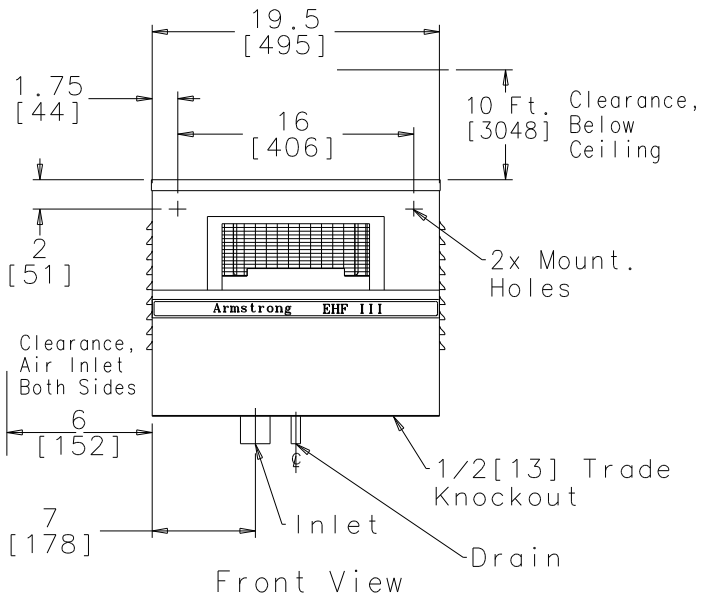

Front View

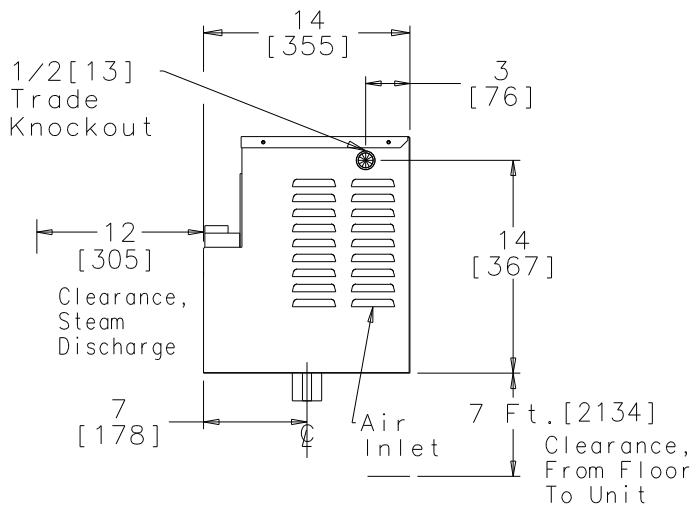

Side View

Dimensions In Inches [mm]  
Unless Otherwise Shown.

## LIST OF MATERIALS:

NAME OF PART	MATERIAL
Cabinet	18 Ga. Stl.(Epoxy Enamel Coating)
Tube, Steam Dispersion	T304 Stainless Steel

## TECHNICAL INFORMATION

DESCRIPTION	MODEL EHF III
Integral Mount	On EHU-703
Inlet Conn.	2 [51] OD
Drain Conn.	5/8 [16] OD

## DESIGN INFORMATION

Capacity, Maximum	120 lbs[55 kg]/hr
Fan CFM	460 CFM
Voltages, Fan 1 $\phi$ vac	120, 208, 240, 480 & 600 *
Amperage, Fan at 120 vac	2.9 amp
Switch, Cutoff(Optional)	Integral
Weight, lbs[kg]	33[15]

\* Step Down Transformer (Optional)  
Needed For Units Using Voltages  
Other Than 120 vac.



Product  
HUMIDIFIER  
FAN PACKAGE  
EHF III

CD No.

1083

Rev; D

Date

3/21/07

By; Paul G.