

EHF Fan Package for Area Type Distribution



Armstrong EHF fan package provides humidity distribution when an air handling duct system is not available. The attractive EHF units are designed to be used with Armstrong atmospheric steam units to include:

Versatility – The EHF-2 unit may be installed directly on top of the EHU-701 humidifier while the EHF-3 unit will mount directly onto the EHU-703. The fan packages also may be hung on a wall – permitting the introduction of humidity with any atmospheric humidifier mounted in another area.

Steel Construction – Cabinet is constructed of 18-gauge steel and finished with tough epoxy enamel. Color matched to companion EHU family.

Long Fan Life – “Air-Over” design cools the blower motor for long operating life.

Capacity and Electrical Information

The maximum humidity dispersion capacity of each EHF-2 area fan package is 30 lb/hr (13.6 kg/hr).

The maximum humidity dispersion capacity of each EHF-3 area fan package is 120 lb/hr (54.4 kg/hr).

Note: The EHF fan packages require a separate 120 volt power supply.

Installation Information

For detailed installation information, please refer to Armstrong Installation Bulletin IB-96 for EHF-2, or IB-95 for EHF-3.

Table 151-1. EHF List of Materials and Weights				
Area Fan Unit Model EHF-2 and 3				
Cabinet	Steel - 18 ga. with Epoxy Enamel Coating			
Blower Fan EHF-2	120 VAC, 60 Hz., 1.3 amp 280 CFM @ 1,380 RPM			
Blower Fan EHF-3	120 VAC, 50/60 Hz., 2.9 amp 465 CFM @ 1,530 RPM*			
Weights				
Model No.	Approximate Shipping Weight		Maximum Operating Weight	
EHF-2 Package	33 lb	15 kg	32 lb	15 kg
EHF-3 Package	34 lb	15 kg	33 lb	15 kg

*208, 240, 480 and 600 VAC available



Designs, materials, weights and performance ratings are approximate and subject to change without notice. Visit armstronginternational.com for up-to-date information.

Table 152-1. Dimensions		EHF-2		EHF-3	
Item	Description	in	mm	in	mm
A	Width	18	457	19-1/2	495
B	Height	13	330	16	406
C	Depth	11-1/2	292	14	356
D	C Mounting Holes	16	406	16	406
E	Height C Electrical Knockout	5-1/4	133	14-1/2	367
F	Depth \odot Electrical Knockout	1-1/2	40	3	76
G	Depth \odot Hose Connection	5-1/2	140	7	178
H	Width \odot Hose Connection	6-1/2	165	7	178
I	Bottom of Cabinet	4-1/8	104	—	—
J	Width Top of Cabinet to Mounting Holes	1-1/8	28	2	51
K	Side \odot Mounting Holes	1	25	1-3/4	44

Figure 152-1. EHF-2

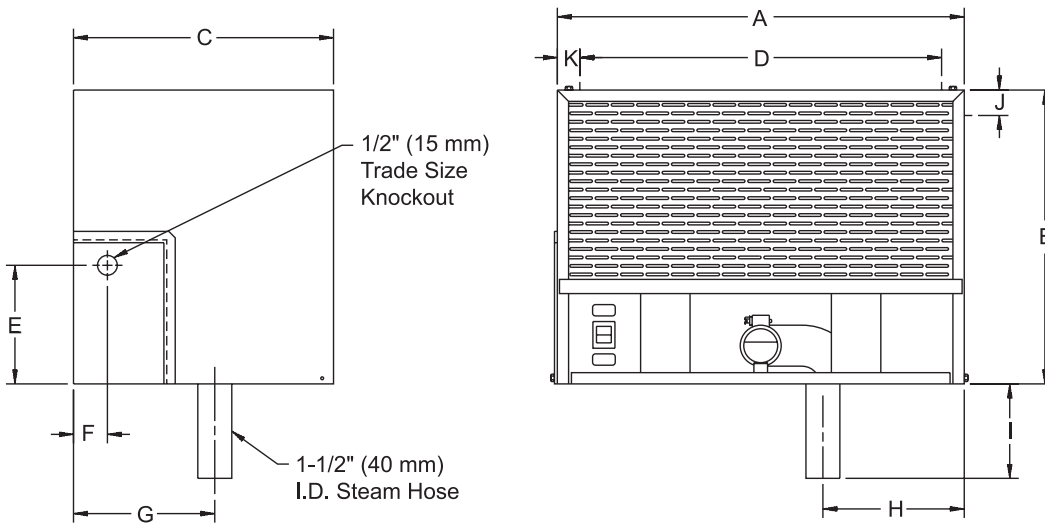
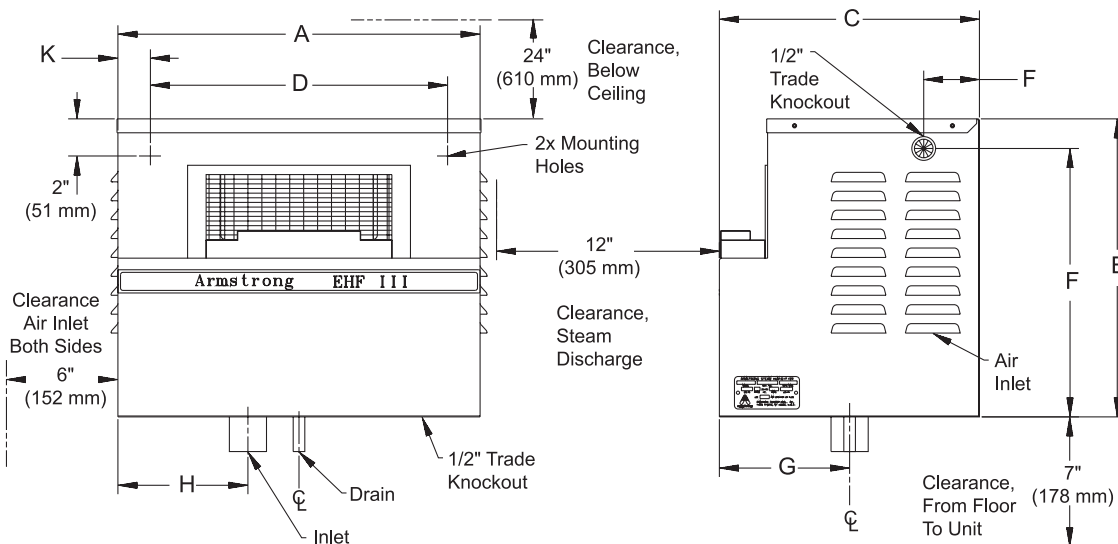

Figure 152-2. EHF-3



Designs, materials, weights and performance ratings are approximate and subject to change without notice. Visit armstronginternational.com for up-to-date information.