



Armstrong

Series GFH Gas Fired HumidiClean (GFH-150, GFH-300 and GFH-450) Category I / III Gas Fired Appliance Installation and Maintenance Manual

WARNING: If the information in this manual is not followed exactly, a fire or explosion may result causing property damage, personal injury or loss of life.

- Do not store or use gasoline or other flammable vapors and liquids in the vicinity of this or any other appliance.
- **WHAT TO DO IF YOU SMELL GAS**
 - Do not try to light any appliance.
 - Do not touch any electrical switch; so do not use any phone in your building.
 - Immediately call your gas supplier from a neighbor's phone. Follow the gas supplier's instructions.
 - If you cannot reach your gas supplier, call the fire department.
- Installation and service must be performed by a qualified installer, service agency or the gas supplier.

Please read and save these instructions. This guide is to be left with the equipment owner.



For Customer Support Call:
(269) 273-1415

Armstrong International, Inc.
816 Maple Street
Three Rivers, MI 49093



Table of Contents

Safety Precautions	4
Installation	5
Site Selecton	5
Mounting Unit	6
Water Fill Supply	8
Electrical Service.....	8
Drainage.....	8
Gas Piping	8
Gas Leak Testing.....	9
Combustion Air	10
Venting (General)	12
Horizontally Vented	13
Vertically Vented.....	13
Steam Distribution	14
Control Wiring.....	15
Control Humidistat.....	15
High Limit Humidistat	15
Air Flow Pressure Switch	16
Alarm Circuit.....	16
Outdoor Enclosure Option.....	16
Start-Up Procedure.....	22

Table of Contents

Principal of Operation	23
Completing a Service Life Cycle	23
End of Season Drain	23
Maintenance	24
Recommended Inspection Schedule.....	24
Replacing Ionic Beds.....	24
Cleaning Level Control Electrodes	25
Burner Assembly	26
Removing / Replacing Heat Exchanger	27
Troubleshooting	28
Diagnostics	28
Clearing Error Codes.....	29
Dip Switch Settings	29
Wiring Schematics.....	30
Parts List	38

Safety Precautions

Warning:

Improper installation, adjustment, alteration, service, maintenance, or use can cause carbon monoxide poisoning, an explosion, fire, electrical shock, or other conditions that may cause personal injury or property damage. Consult a qualified installer, service agency, local gas supplier, or your distributor or branch for information or assistance. The qualified installer or agency must use only factory authorized and listed kits or accessories when modifying this product. A failure to follow this warning can cause electrical shock, fire, personal injury, or death.

- Special attention should be given to the application of this humidifier. It is very important the proper vent pipe is used in regard to material and size. Accurate information should also be given with respect to gas input rate, and unit sizing. Improper installation or misapplication of the humidifier can result in excessive required maintenance, or can cause permanent component failure.
- When working on equipment, observe precautions in this literature, tags, and labels attached to or shipped with the unit and other safety precautions that may apply. Wear safety glasses and work gloves. Have fire extinguisher available during start-up, adjustment procedures, and service calls.
- Do not use this appliance if any part has been under water. Immediately call a qualified service technician to inspect the appliance and replace any part of the control system and any gas control that has been under water.
- Do not lift humidifier by gas controls, gas manifold, firebox, or control panel. This unit should only be lifted by cross beams between the support legs.
- Should overheating occur, or the gas supply fails to shut off, shut off the manual gas valve to the appliance before shutting off the electrical supply.

Precautions:

- The installation must conform to the requirements of the authority having jurisdiction or, in the absence of such requirements, to the National Fuel Gas Code, ANSI Z223.1 (latest edition). In Canada, the installation of this unit must comply with local plumbing or waste water codes and other applicable codes and with the current code CAN/CGA-B149.1, "Installation Code for Natural Gas Burning Appliances and Equipment" or CAN/CGA-B149.2, "Installation Code for Propane Burning Applications and Equipment."
- Do not install in potentially explosive or flammable atmospheres laden with grain dust, sawdust, or similar airborne materials.
- Installation of humidifier in high humidity or salt-water atmospheres will cause accelerated corrosion, resulting in a reduction of the normal life-span of the unit.
- To prevent premature heat exchanger failure, do **NOT** locate **ANY** gas-fired units in areas where chlorinated, halogenated or acid vapors are present in the atmosphere.
- Locate the humidifier in an area clear of combustible materials, gasoline, and other flammable vapors and liquids.
- Do not locate units in tightly sealed rooms or small compartments without provision for adequate combustion air and venting. Combustion air must be supplied to the confined space through a minimum of two permanent openings in the enclosure, at least one near the bottom. They should provide a free area of one square inch per 1000 BTU per hour rating of the unit with a minimum of 100 square inches for each opening, whichever is greater. See information on page 10 for additional details

Installation

Check Shipment. A claim should be filed with the transportation company, and reported to Armstrong International, Inc. if any items are missing or damaged.

Important: Remove all shipping materials before installing the humidifier

- Humidifier flue gasses must be vented to the outside atmosphere.
- Power supply disconnect switch must be in the immediate vicinity of the unit and must be in the off position while making wiring connections to prevent electrical shock and equipment damage. Wiring of this unit must comply with all manuals, wiring labels included and all local codes.
- Turn off all gas while installing the run-out and manual shut-off valve for the humidifier.

Site Selection. The humidifier should be installed in an easily accessible location. Do not install the unit where malfunction of the humidifier might cause damage to non-repairable, irreplaceable, or priceless property. Locating the Humidifier

- Provide a level, solid foundation for the humidifier. Locate the humidifier as near as possible to chimney or outside wall so that the flue pipe from the humidifier is short and direct. The location should also be as such that the gas ignition system components are protected from water during humidifier operation and service.
- The humidifier should be installed in a location away from drafts and properly protected. If installed in a separate room, follow the instructions concerning combustion and ventilation air.
- The humidifier should be located in an area where leakage from the tank or its connections will not result in damage to the adjacent structure or to lower floors of the structure. When such locations cannot be avoided, it is recommended that a suitable drain pan, adequately drained, be installed under the humidifier. The pan must not restrict combustion airflow.
- The humidifier shall not be installed directly on carpeting, tile or other combustible material other than wood flooring.
- Install humidifier so electrical components are protected from water.
- This appliance must be installed in a location free of insulation materials. Some insulating materials may be combustible. Appliance area must be inspected during installation, or when insulation is added.
- Minimum horizontal clearance of 4 feet from electric meters, gas meter regulator, and relief equipment.

Figure 5-1

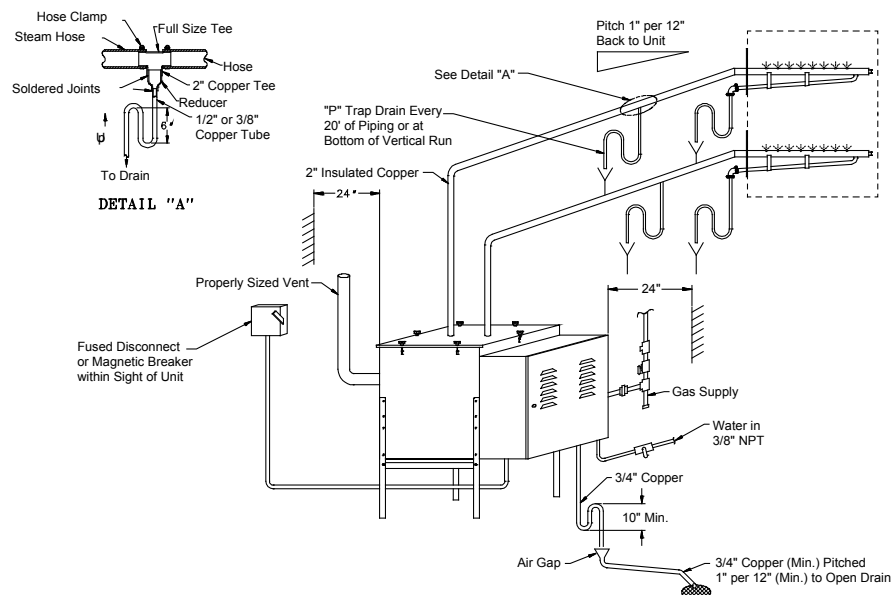

Mounting Unit.

The Series GFH is designed to be floor mounted on a level surface.

Required Clearance

For recommended service and maintenance purposes, the following clearances should be maintained:

- Front: 40"
- Left Side: 1"
- Right Side: 1"
- Rear: 1"
- Top: 36"

**Figure 6-1.
Model 150**

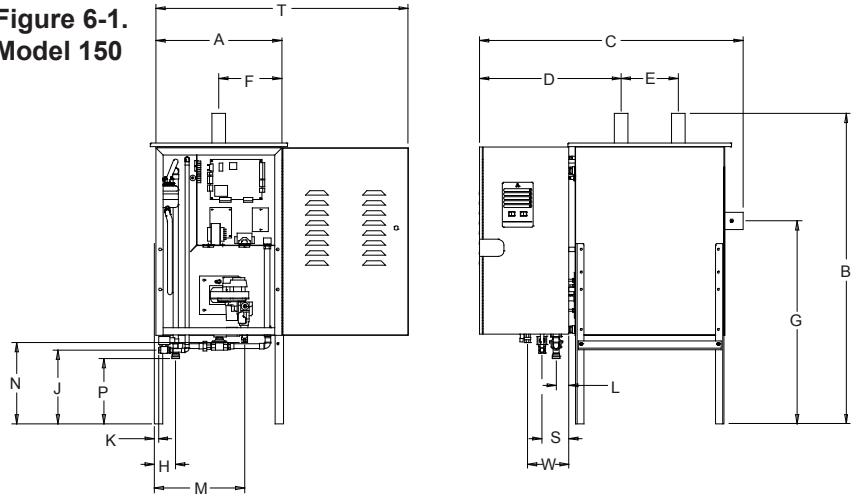

**Figure 6-2.
Model 300**

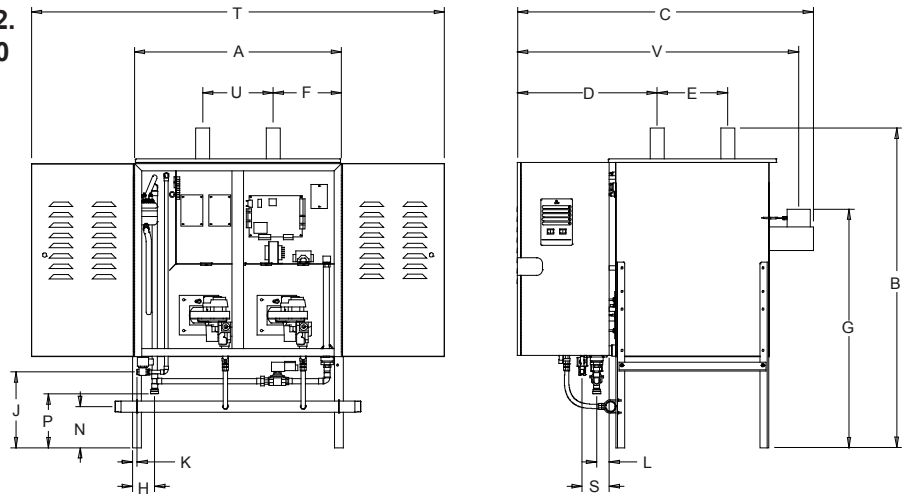

**Figure 6-3.
Model 450**

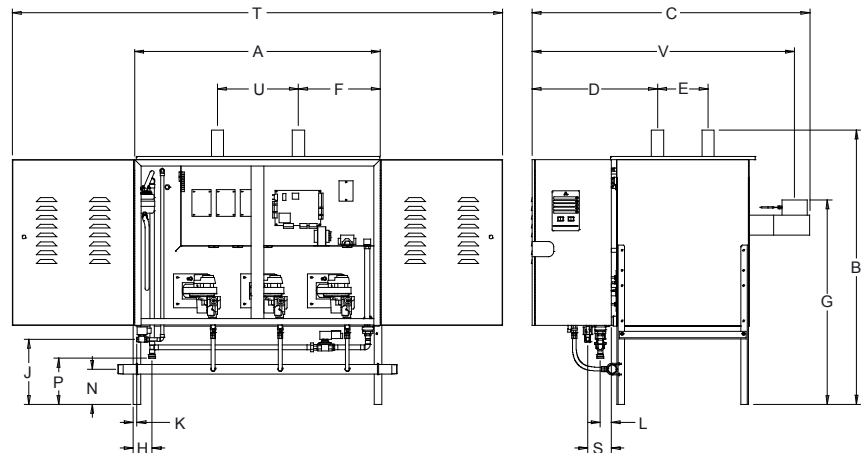

Table 7-1. GFH Gas Fired HumidiClean Physical Data

	GFH-150		GFH-300		GFH-450	
	in	mm	in	mm	in	mm
A - Tank Width	22	559	35-1/4	895	48-1/2	1232
B - Overall Height	54-3/16	1378	54-3/16	1376	54-3/16	1376
C - Overall Width	46-1/8	1172	50-3/8	1280	54-7/8	1394
D - Steam Outlet to End of Cabinet	24-13/16	630	23-13/16	605	24-13/16	630
E - Steam Outlet Spacing	10	254	12	305	10	254
F - Steam Outlet to Edge of Tank	11	279	11-5/8	295	16-1/8	410
G - Vent Outlet to Floor	35-1/2	902	40-1/2	1029	40-1/2	1029
H - Drain Outlet to Edge of Tank	3-3/4	95	3-3/4	95	3-3/4	95
J - Water Inlet to Floor	12-7/8	327	12-7/8	327	12-7/8	327
K - Water Inlet to Edge of Tank	3/4	20	3/4	20	3/4	20
L - Drain Outlet to Edge of Tank	2-1/4	57	2-1/8	54	2-1/8	54
M - Gas Inlet to Edge of Tank	15-13/16	402	15-1/2	402	-	-
N - Gas to Floor	14-1/4	362	7	178	7	178
P - Drain Outlet to Floor	11-7/16	291	9	232	9-1/8	232
S - Water Inlet to Edge of Tank	4-3/4	121	4-5/8	117	4-5/8	117
T - Cabinet Opening Clearance	44-1/8	1121	70-5/16	1786	96-13/16	2459
U - Steam Outlet Spacing	-	-	12	305	16	406
V - Vent Outlet to Front of Cabinet	-	-	47-7/8	1216	51-7/8	1317
W - Gas Inlet to Edge of Tank	7-1/4	84	-	-	-	-
Water Inlet	3/8" NPT	10	3/8" NPT	10	3/8" NPT	10
Drain Connection	3/4"	20	3/4"	20	3/4"	20
Gas Inlet	1/2" NPT	15	1-1/2" NPT	40	1-1/2" NPT	40
Vent Size - Category I (Vertical)*	5"	127	7"	178	8"	203
Vent Size - Category II (Horizontal)**	3"	75	4"	100	5"	127
Steam Outlets	2-3/8" OD / 4" Flg.					
Dry Weight - Lbs (Kg)	295 (134)		415 (188)		540 (245)	
Wet Weight - Lbs (Kg)	700 (318)		1110 (503)		1670 (758)	
Shipping Weight - Lbs (Kg)	425 (193)		550 (249)		700 (318)	

* - "B" -Vent can be used in vertical vent piping orientation only.

** - Category III vent piping is required for horizontal vent pipe orientation.

Maximum vent pipe distance will be 100' equivalent piping distance in either case.

Table 7.2. GFH Gas Fired Humidifier Capacities (Natural Gas)

Model Number	Steam Capacity		Max. Input btu/hr
	lb/hr	kg/hr	
GFH-150/GFH-150DI	155	70	210,000
GFH-300/GFH-300DI	315	143	420,000
GFH-450/GFH-450DI	475	215	630,000

Note: For high altitudes above 2000 ft, a de-rating factor will need to be applied. The standard de-rating factor will be 4% per 1000 ft above 2000 ft.

Table 7.3. GFH Gas Fired Humidifier Capacities (Propane Gas)

Model Number	Steam Capacity		Max. Input btu/hr
	lb/hr	kg/hr	
GFH-150/GFH-150DI	150	68	200,000
GFH-300/GFH-300DI	308	140	400,000
GFH-450/GFH-450DI	465	211	600,000

Note: For high altitudes above 2000 ft, a de-rating factor will need to be applied. The standard de-rating factor will be 4% per 1000 ft above 2000 ft.

Water Fill Supply

The humidifier can use any potable or purified water supply. Water pressure must be 25 – 125 psi (1.7 – 8.6 bar). Water temperature must be less than 140°F (60°C). Average fill rates for all models is 3gpm (0.19 l/sec).

1. Install a shut-off valve near the unit.
2. Connect the water supply to the 3/8" NPT fitting on the fill water solenoid valve.

Electrical Service Wiring

1. The control cabinet will require 120V 1ph supply to the terminals L1 and L2 in the cabinet.
2. A standard 120V 15A service is required.
3. The Series GFH must be electrically grounded in accordance with local codes, or in the absence of local codes, with the National Electrical Code, ANSI / NFPA 70, and / or the CSA C22.1 Electrical Code.

Drainage

A 3/4" connection is available to connect a 10" P trap to facilitate proper draining. Please see Figure 5-1 for information. Average drain rates for all models is 3gpm (0.19 l/sec).

Gas Piping Selection

Caution:

Gas pressure to humidifier controls must never exceed 14" WC (1/2 psi). A 1/8" NPT plugged tapping, accessible for test gauge connection, must be installed immediately upstream of the gas supply connection to the appliance.

Installation of piping must be in accordance with local codes, and ANSI Z223.1, "National Fuel Gas Code," or CAN / CGA-B149 in Canada. Do not use flexible connectors.

Piping to unit should conform with local and national requirements for type and volume and gas handled, and pressure drop allowed in line. Refer to Table 9-1 and 9-2 to determine the cubic feet per hour (cfh) for the type of gas and size of unit to be installed. Using this value and the length of pipe necessary, determine the pipe diameter. Where the same main serves several units, the total capacity, gas flow (cfh), and length of main must be considered. Avoid pipe sizes smaller than 1/2". Table 9-1 allows for the usual number of fittings with a 0.3" WC pressure drop.

- After threading and reaming the ends, inspect piping and remove loose dirt and chips.
- Support piping so that no strains are imposed on unit or controls.
- Use two wrenches when connecting piping to unit controls.
- Provide a drip pocket before each unit and in the line where low spots cannot be avoided.
- Take-off to unit should come up from top or side of main to avoid trapping condensate.
- Piping subject to wide temperature variations should be insulated.
- Pitch piping up toward unit at least 1/4" per 15 feet of horizontal run.
- Compounds used on threaded joints of gas piping must be resistant to action of liquefied petroleum gasses.
- Purge air before lighting unit by disconnecting piping at gas control. **In no case should line be purged into heat exchanger.**
- After installation, check field piping and humidifier gas train for gas leaks. Do not use soap solution on humidifier gas train.
- Install a ground joint union and a manual shut-off valve immediately upstream of the unit including a 1/8" NPT plugged tapping accessible for test gauge connection. Plugged tappings for test gauges are located on all gas valves.

- Allow at least 5 feet of piping between any high pressure regulator and unit pipe connection.
- The physical location of the manual main shut-off valve external to the jacket when local codes require the installation of such a valve.

Figure 9-1

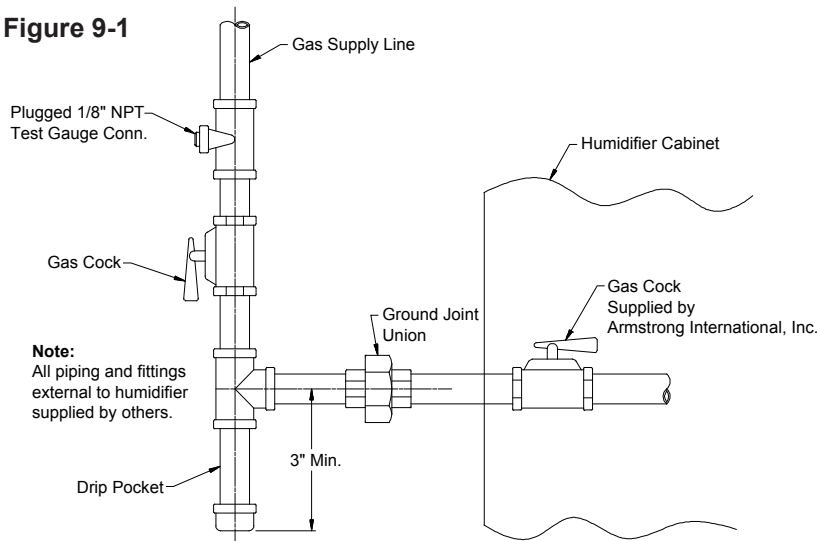

Gas Line Connection Sizes	
GFH-150	1/2" NPT (15 mm)
GFH-300	2" NPT (50 mm)
GFH-450	

Table 9-1. Gas Pipe Capacities

Length of Pipe (Feet)	Gas Flow in Piping (Cu. Ft. per Hour)				
	Iron Pipe Size (NPT) Inches				
	1/2	3/4	1	1-1/4	1-1/2
10	132	278	520	1050	1600
20	92	190	350	730	1100
30	73	152	285	590	890
40	63	130	245	500	760
50	56	115	215	440	670
60	50	105	195	400	610
70	46	96	180	370	560
80	43	90	170	350	530
90	40	84	160	320	490
100	38	79	150	305	460

Table 9-2. Specific Gravity Conversion Factors

Natural Gas		Propane Gas	
Specific Gravity	Factor	Specific Gravity	Factor
0.55	1.04	1.50	0.633
0.60	1.00	1.53	0.626
0.65	0.962	1.60	0.612

Gas Leak Testing

- When leak testing the gas supply piping system, the humidifier and its gas shut-off valve must be disconnected during any pressure testing in excess of 14" WC (1/2 psi). The humidifier must be isolated from the gas supply piping system by closing the field-installed manual shut-off valve during any pressure testing equal to or less than 14" WC (1/2 psi).
- Verify the gas supply pressure upstream of gas control unit is 7" WC on natural gas, or 11" WC on LP Gas. Purging of gas should be performed as described in ANSI Z223.1 (latest edition) or, in Canada, CAN/CGA-B149 codes.
- Minimum Supply Pressure: 5" WC for Natural Gas and 10" WC for LP

Combustion Air

Caution:

Air for combustion must not be contaminated by halogenated hydrocarbons, which include fluoride, chloride, bromides and iodide. These elements are found in aerosol sprays, detergents, bleaches, cleaning solvents, salts, air fresheners, and other household products. Humidifier warranty is voided when failure of gas equipment is due to operation in a corrosive atmosphere.

Caution:

If the humidifier is installed in an unconfined space within a building of conventional frame, masonry or metal construction, infiltration air is normally adequate for proper combustion and ventilation. If the humidifier is installed in a confined space provisions for combustion air must be made. Any ventilation equipment located in immediate proximity of the humidifier could cause a negative pressure condition at the humidifier. Appropriate make-up air must be supplied to compensate for all other ventilation equipment in addition to that required by the humidifier.

Proper operation of the Series GFH requires air for combustion and ventilation. Provisions for combustion and ventilation air must comply with Section 5.3, Air for Combustion and Ventilation, of the National Fuel Gas Code, ANSI Z223.1-1988, or acceptable provisions for the local building codes. Canadian installations must be installed in accordance with sections 7.2, 7.3 and 7.4 of the CAN/CGA.B149 Installation Codes, and all authorities having jurisdiction.

Do not block or obstruct any openings on the appliance, spaces around the appliance, or air openings adjacent to the appliance area.

Do not block the flow of combustion or ventilation air. Openings must be provided for necessary combustion air to enter the area where the humidifier is located from an outside source. Any enclosed space, such as mechanical rooms, must be ventilated to provide the proper supply of fresh air for burner combustion. The size of the opening is dependent upon the rating of the burner.

- A confined space is one having a volume of less than 50 cubic feet per 1000 BTU/hr of the aggregate input of all appliances within that space.
- The air is to be supplied by two equal size openings, one within 12" below the ceiling, and one within 12" above the floor.
- An opening must be provided not less than one square inch per 1000 BTU/hr of the total input rating of all the appliances sharing the enclosure. The minimum opening is to be 100 square inches.
- Buildings of unusually tight construction must have the combustion and ventilation air supplied from outdoors, or a freely ventilated attic or crawl space.
- If air is supplied from outdoors, directly or through vertical ducts, there must be two openings sized at not less than 1 square inch per 4000 BTU/hr of total input rating of all appliances sharing the enclosure.
- If horizontal ducts are to be used, each opening must be sized at not less than 1 square inch per 2000 BTU/hr of the total input rating of all the appliances sharing the enclosure.
- If the duct openings are to be covered with a protective screen or grill, the mesh will not be smaller than ¼" to prevent clogging by lint or other debris.

Sealed Combustion Air

All models in the GFH family will be capable of sealed combustion with the installation of the sealed combustion kit. This kit will facilitate combustion air being drawn thru 4" PVC pipe for a distance up to 40 feet equivalent piping from an outdoor air source.

The outdoor air source can be a connection outside the building or a connection to an outdoor air plenum inside the building. If the inlet combustion air is to be drawn in from a connection outside the building, special precautions must be made, such as proper termination outside the wall, and a screen on the air inlet to prevent any debris from entering the air inlet pipe.

The GFH-150 will require a 4" x 2" Tee to be installed on the supplied 2" section of PVC pipe, then 4" PVC / CPVC for the inlet air pipe.

The GFH-300 and GFH-450 will come shipped with a 4" PVC connection for the supply air pipe to be connected.

See Figure 11-1 and 11-2 below for further detail.

Figure 11-1

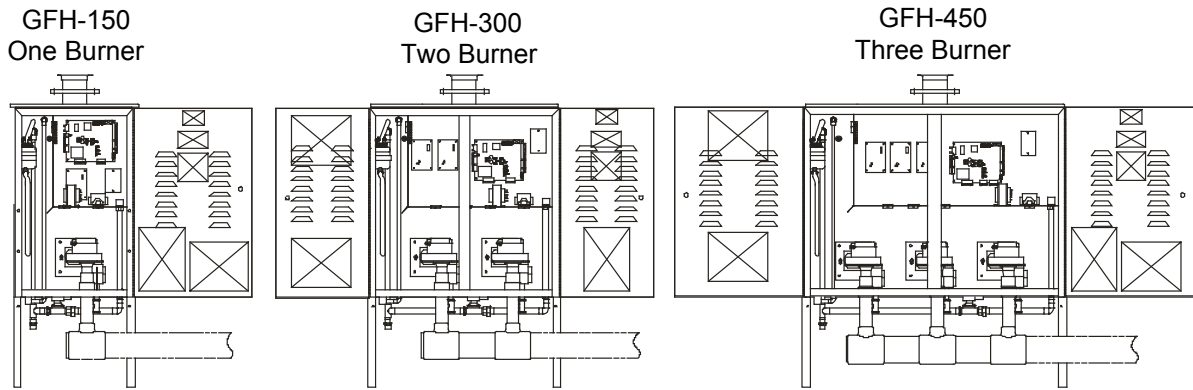

* Refer to special Sealed Combustion Package Venting Requirements on Page 14.

Figure 11-2

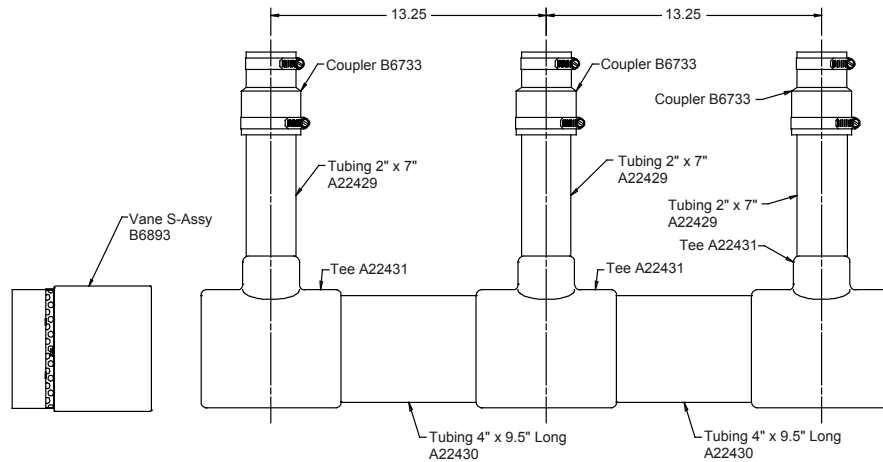

Venting

Overview - This humidifier is a Category I / III appliance, which means it produces a positive pressure in the vent system when it is exhausting the appliance flue products to the outdoors. It may be vented vertical or horizontal but special flue pipe must be used which is listed for Category I / III appliances for horizontal piping. In the case of vertical flue piping arrangement, type B double wall vent pipe is acceptable. Verify proper flue piping sizes from Table 7-1 as the vent pipe sizes may differ based on orientation of vent piping. Category I / III appliances also produce flue gas temperatures which are above 250°F, therefore, plastic PVC or CPVC vent piping is not acceptable. This humidifier may not be common vented with any other gas, wood, or oil fired products.

- The Series GFH is a Category I / III fan assisted appliance.
- The maximum vent length is 100 equivalent feet (40 ft. if Sealed Combustion Package is used) of appropriate vent pipe with each elbow considered the equivalent of 5 feet of straight pipe. The minimum vent length is 10 feet. No more than 6 elbows should be used in the system.
- By properly venting the humidifier, proper removal of combustion gases can be assured. Proper venting also assures all the by-products of the combustion gases are removed.
- Connecting the humidifier to the gas vent or chimney should be in accordance with Part 7, Venting of Equipment, of the National Fuel Gas Code, ANSI Z223.1, or Section 7, Venting systems and Air Supply Appliances, of the CAN/CGA B149 Installation Codes, the local building codes, and the vent manufacturer's instructions.
- The stack size to be used with the Series GFH should be in accordance with Table 7-1. Reduced size vent piping should not be used. The connection provided with the GFH is considered to be a MALE connection.
- The maximum flue gas temperature at the humidifier vent connector will not exceed 460°F (238°C). Use only special gas vents listed for use with Category I / III gas burning appliances. The vent pipe systems shall be listed to UL Standard 1738 in the USA and ULC-S636 in Canada. Some of the approved manufacturers to be used with the series GFH Gas Fired Humidifiers are Duravent (Category I) and Flexmaster Z-Flex or Metal Bestos (Category III).
- Each manufacturer has special UL listed wind caps for vertical venting with their brand of vent pipe. The vent material manufacturer's instructions for vertical venting must be followed.
- If vent pipe is being installed in an existing chimney, have chimney inspected for blockages, and cleaned if necessary.
- Inspect vent pipe for proper and tight construction. Verify there are no restrictions or blockages in the vent pipe.
- Chimney or vent pipe must extend at least 3 feet above its highest passage through the roof and at least 2 feet above any ridge within 10 feet of the chimney. (Local codes apply.)
- Clearances must be observed for any combustible material from the vent connector. This clearance should be a 6" minimum, unless the combustible materials are protected in accordance with applicable codes.
- **VENTING INTO AN UNLINED MASONRY OR CONCRETE CHIMNEY IS PROHIBITED BY CODE.**
- This humidifier cannot share a chimney flue servicing a separate appliance designed to burn solid fuel. Never connect this humidifier to a chimney being used by a fireplace unless the fireplace has been permanently sealed off.
- This appliance may not be common vented with any other natural draft gas appliances or power or forced exhausted appliance.

- Any vent connectors exposed to ambient temperatures less than 30°F (-1°C) should be insulated.
- If this humidifier is vented to a lined masonry chimney, the chimney must be sized and installed in accordance with the provisions of the National Fuel Gas Code, or Canadian CAN/CGA.B149 requirements. Vent connectors from the humidifier to the chimney should be made with a vent pipe rated for Category I/III appliance rating. See Table 12-1 for recommended manufacturers.
- A minimum of turns and elbows should be used, and the vent pipe should be run as directly as possible.
- Even though the vent system to be used is stainless steel, care must be taken that no condensate from combustion be allowed to sit in the vent pipe. Therefore, it is important to always provide the proper pitch for condensate draining purposes.
- Care must be taken whenever the vent system is run through a cold area of the building as this will increase the likelihood of flue gases condensing in the flue pipe. To reduce the risk, the flue pipe should be insulated when it passes through a cold area or an area where there is a great amount of circulating air passing over the flue pipe.
- To ensure there will be no movement after installation, the vent pipe must be rigidly supported every 5 feet or less with hangars or straps. The humidifier should not be supporting the weight of the vent pipe. The vent pipe should at no time pass through or extend into any circulation air duct or plenum.
- If the vent pipe should need to run thru floors, ceilings, or walls, proper clearances from combustible materials must be observed. The vent pipe will also require fire stopping according to the National Fuel Gas Code requirements, ANSI Z223.1 and Canadian Standards CAN / CGA.B149.

In installations where an existing vent system may be used, the existing vent system must be inspected for condition, size, type of vent material, and height to meet the requirements in these instructions. Condensation and corrosion could occur if the existing vent system is too large and should be changed to meet the requirements in this instruction manual. When connecting the humidifier to a gas vent or chimney, the installations shall be in accordance with Part 7, Venting of Equipment, of the National Fuel Gas Code, ANSI Z223.1, or Section 7, Venting Systems and Air Supply Appliances, of the CAN/CGA.B149 Installation Codes, the local building codes, and the vent manufacturer's instructions.

Horizontally Vented Humidifier

- Maintain an upward slope of 1/4" per foot on all horizontal vent pipe runs.
- To ensure there will be no movement after installation, the vent pipe should be rigidly supported every 5 feet or less with hangars or straps. The humidifier should not be supporting the weight of the vent pipe. The vent pipe should at no time pass through or extend into any circulation air duct or plenum.
- Distances from the vent terminal adjacent to public walkways, buildings, and operable windows and building openings should be in accordance with the National Fuel Gas Code, ANSI Z223.1 and/or CAN/CGA.B149 Installation Codes
- The vent terminal location must be at a sufficient height above ground level to prevent blocking by expected snowfall
- Building materials should be protected from corrosion by flue gases
- At the exit point outside the building a proper vent termination "cap" must be used as shown in Fig. 13-1. The dimensions shown must be followed in order for the humidifier to work properly under high wind conditions.

Figure 13-1

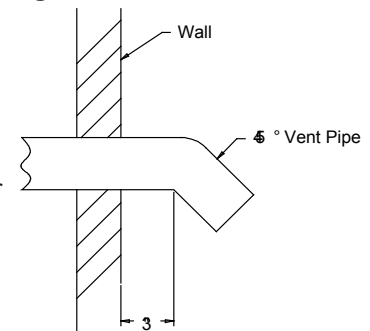

Vertically Vented Humidifier

- The humidifier may be vented vertical but it should be done with as straight and short of a run as possible and in all cases must be within the stated minimum and maximum vent lengths of 10' to 100'.

- When vented vertical it may vent into a chimney when the above rules are followed concerning lining; or it may use a listed Category III vent with a UL listed wind cap at the termination above the roof.

Figure 14-1
Sealed Combustion Package Venting Requirements

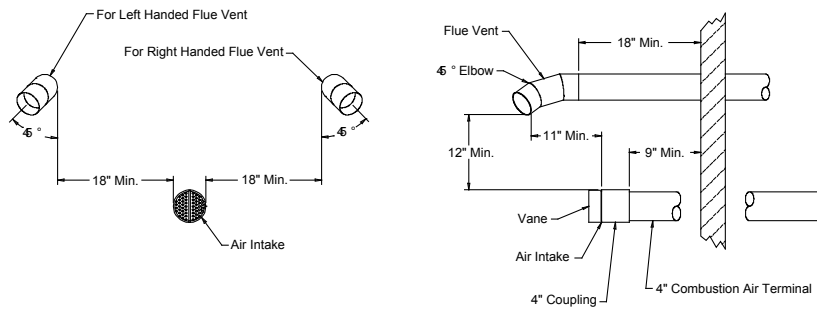

- Sealed combustion can be used with horizontal or vertical venting, but the intake and exhaust must be located in the same pressure zone. See Figure 14-1 for mounting configuration.

Steam Distribution

1. The dispersion tube should be proper length. Verify correct size from Table 14-1.
2. Install dispersion tube horizontally in duct so holes face upward. Air flow must be vertical up or horizontal. Do not restrict duct with a height of 8" (20 cm) or less. Installations over 2000 FPM (10 m/s) air velocity are not recommended. Consult factory if air flow is vertical down or air velocity is over 2000 FPM (10 m/s). Do not install in ducted systems with static pressure exceeding 6" WC (15 cm).
3. The dispersion tube should be located upstream of a straight duct run, without obstructions, 10 feet (3 m) or more in length. Consult the factory if this distance is not available.
4. Use the template provided to cut dispersion tube installation holes. Fasten the mounting plate to duct with sheet metal screws. If the dispersion tube is 36" (91 cm) or longer, support the far end with threaded rod or similar means.
5. The dispersion tubes should be connected to the GFH tank using copper pipe (stainless steel for DI units). The pipe size of the steam run should correspond with the nominal pipe size of the steam outlet on the generator. Hose cuffs are provided with the unit to connect to the steam supply piping. Pitch pipe back to unit 1" (2.5 cm) per foot. The steam pipe must be free of kinks and sags to allow for gravity drainage of condensate. Maximum pipe run distance from tank to dispersion tube is 40 feet (12 m) equivalent piping length. Avoid excessive use of elbows or 45° changes in direction. A "P" trap drain should be installed every 20 feet (6 m) of piping run or at the bottom of vertical runs that cannot drain back to the tank. See Fig. 5-1 for "P" trap detail.

Alternative for shortened non-wettable vapor trail

For applications with particularly limited downstream absorption distance, Armstrong HumidiPack may be considered. HumidiPack is a prefabricated separator/header and multiple dispersion tube assembly. It provides uniform distribution and shortened non-wetting vapor trail. Consult Armstrong Installation Bulletin No. 560 for more information.

Table 14-1

Series GFH and GFH-DI	Series GFH and GFH-DI "DL" Dia.	Steam Dispersion Tube Length (mm)	Duct Width	
			Min. (mm)	Max. (mm)
DL-1	2-3/8" (60 mm)	12" (305")	11" (279)	16" (406)
DL-1.5		18" (457)	17" (432)	22" (558)
DL-2		24" (610)	23" (584)	34" (863)
DL-3		36" (914)	35" (889)	46" (1168)
DL-4		48" (1220)	47" (1194)	58" (1473)
DL-5		60" (1524)	59" (1499)	70" (1778)
DL-6		72" (1829)	71" (7803)	82" (2082)
DL-7		84" (2134)	83" (2108)	94" (2387)
DL-8		96" (2438)	95" (2413)	106" (2692)
DL-9		108" (2743)	107" (2718)	118" (2997)
DL-10	120" (3048)	119" (3022)	130" (3302)	

*Minimum of two tubes must be used.

Control Wiring

Wiring for low voltage controls should not run in same conduit as the power supply. Use of shielded wire or a separate dedicated metal conduit is recommended. Refer to Figure 15-1.

Control Humidistat

1. Locate control humidistat where it will sense the average air condition of the space to be humidified. Avoid areas of restricted circulation or locations where the sensor will be subjected to drafts, localized heat or moisture sources.
2. Optional duct mounted humidistats are available to sense return or exhaust air, if preferred.
3. The Series GFH is capable of operating with control signals of 0-10 Vdc, 4-20 mA, 0-5VDC or 1.9-3.9 Vdc. See Fig. 15-1 for location of switches and Table 21-1 for correct switch setting. Refer to Figures 15-1 and 15-2 for appropriate wiring.
4. Wire standard Armstrong 0-10 Vdc humidistat as shown in Figure 15-1.

Figure 15-1

Note: All Switches Are Open on Fault Type.
Set Voltage Source Jumper to 24 VAC. Set Jumper to 0-10 VDC

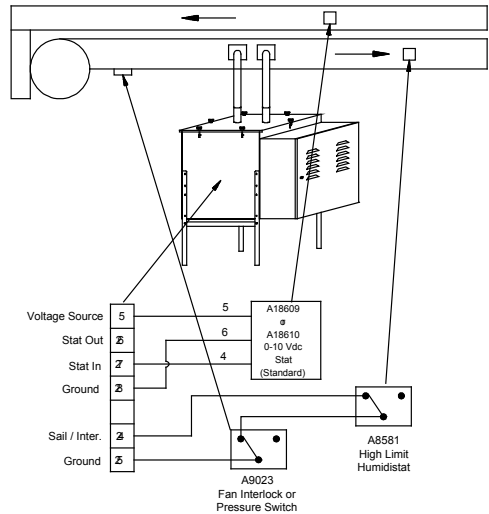
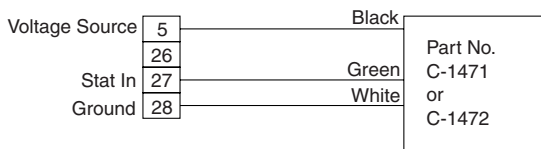

Figure 15-2

Armstrong C-1471 & C-1472
1.9 - 3.9 Vdc



Set Stat Input Jumper to 1.9 - 3.9 Vdc (J5)
Set Stat Voltage Jumper (J6) to 12 VAC

4 - 20 mA Signal

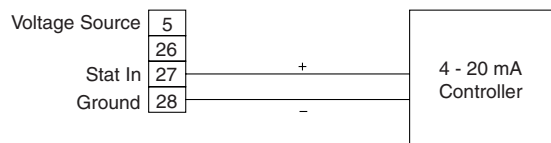

Set Stat Input Jumper to 4 - 20 mA (J4)

0 - 10 VDC other than
Armstrong Standard Stat



Set Stat Input Jumper to 0 - 10 Vdc (J2)

0 - 5 Vdc Signal

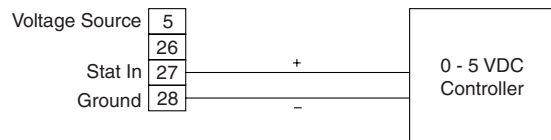

Set Stat Input Jumper to 0 - 5 Vdc (J3)

High Limit Humidistat

A duct mounted High Limit Stat (Armstrong Part A8581) is recommended as a precaution against localized saturation in the duct. It is an on-off controller that opens the contact on a rise in humidity (opens on fault). See Figure 15-1 for wiring terminals and overall wiring diagrams.

It should be mounted 6 to 10 feet downstream from the steam dispersion tube (see Fig. 15-1). The high limit stat must be upstream of filters, silencers, takeoffs, etc. since these devices can reduce duct humidity and prevent the high limit stat from doing its job. Complete mounting instructions are contained in the High Limit Stat package.

Fan Interlock Switch

A fan interlock switch is recommended to deactivate the humidifier when there is insufficient air flow in a duct system. A duct pressure switch is preferred as a fan interlock device. The pressure switch should open on insufficient air flow (opens on fault). See Figure 15-1 for wiring terminals and overall wiring diagrams.

Complete

installation and wiring instructions are contained in the duct pressure switch package. Armstrong Pressure Switch: (Armstrong Part A9023) All Pressure and electrical connections and set point adjustments are on side for each installation. Temperature limit: 32°F. to 180°F. Maximum surge pressure: 10 psig Rated pressure: 45" H₂O Pressure connections: 1/8" NPT Operating range: 0.07 to 0.15" H₂O

Installation

- Select a location that is free from excessive vibration, corrosive atmosphere and within temperature limitations.
- Connect switch from pressure source with tubing (1/4" O.D. is recommended) to high pressure port. The low pressure port is left open to atmosphere.

Note: Above procedure is for downstream side of fan installation. For fan suction side installation, see instructions accompanying switch.

- Electrical connections to the switch are provided by means of screw terminals marked common and normally open. The normally open contacts close when pressure increases beyond the set point.
- Complete instructions are contained in the pressure switch package.

Note: Limit switches (high limit and fan interlock switches) open on fault.

Figure 16-1

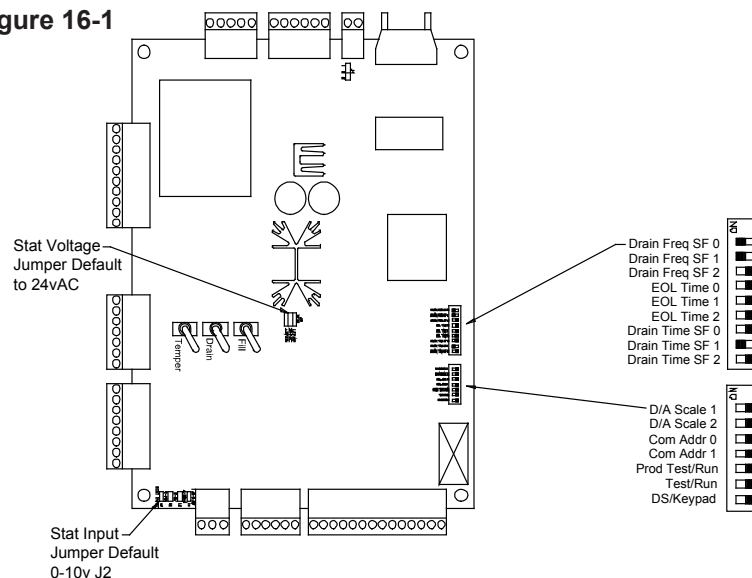

Alarm Circuit

The connections labeled REM ALM on the TB6 connector on PC board, are connections for a class II NEC alarm circuit (switch closure only, 1 amp. maximum 24 Vdc or 0.5 amp. @ 125 Vac). The switch will close when the error or service LEDs are energized.

Gas Fired Outdoor Enclosure Option

The Series GFHE unit is intended to be used where the gas fired unit will need to be mounted outdoors.

Site Selection:

- Provide a level, solid foundation for the humidifier. In the case where the unit will be mounted on a curb, verify a gasket will be used between the curb and the GFHE unit to protect against moisture entering the building. If the unit will be mounted on poured concrete pad, verify the pad will properly support the unit and all support point dimensions are accurate.
- The GFHE was intended to only be moved either by a forklift using the skid the unit was shipped on, or by lifting the hooks provided.
- If being moved by a forklift, with skid in place, make sure the forks extend the entire width of the unit. Forks that do not extend the entire width could cause the unit to tip, which could create an unsafe moving situation or could cause the unit to be dropped, causing permanent damage to the unit.
- If the unit is to be lifted using the lifting hooks, a load spreader must be used. The load spreader shall be wide enough to ensure the lifting cables clear the sides of the units. The load on the cables should be distributed for even lifting, preventing the unit from tipping.
- Verify all frame and support bolts have not loosened during shipping.
- The humidier should be mounted in a location where all panels can be easily accessible and removed if required for servicing.
- The humidifier should be located in an area where the fresh air inlets are not close to any other exhaust systems, or in any location where potentially flammable vapors or liquids could be taken in to the combustion chamber.
- Remove unit from shipping skid prior to locating final position of unit.
- Please check drawings below for particular model numbers to locate all utility knockout locations in outdoor enclosure for all utilities and flue piping. Use the appropriate plugs or knockouts for each utility required. In the event any utility piping needs to be run thru the bottom of the unit, all holes will have to be sealed around the piping. The bottom of the unit is also used as the drain pan.
- All water lines should be run to eliminate the possibility of freezing, and should be insulated.
- Combustion air intakes are located on the access panels. In the instance a sealed combustion package is used, verify all connections are secure and filter is in palce in the inlet filter box. Air intakes should be positioned to avoid having natural air flow blowing directly into the air intakes.
- Verify filter is in place for electronics cabinet air intake.
- If the unit was provided with optional factory installed sealed combustion kit, verify all clamps and connections are secure.
- In environments where the GFHE unit will be exposed to extreme cold conditions, an optional heater package can be provided. If the heater package is installed, there will be two non-adjustable thermo stats factory pre-set to energize the heaters if the ambient temperature in the cabinet fall below 60F. The heaters will stay energized until the internal cabinet temperatures reach 75F.
- External flue piping will be filed installed, and supplied by installing contractor. Flue piping can be installed on either side of the unit (see drawings on pages 18-21). Consult local codes for exact flue height requirements. B-Vent type piping will be acceptable for all the outdoor enclosure units.
- An optional curb package can be provided with the unit. Please consult factory, or your local Armstrong Sales Representative for more information.

Gas Fired Roof Installation

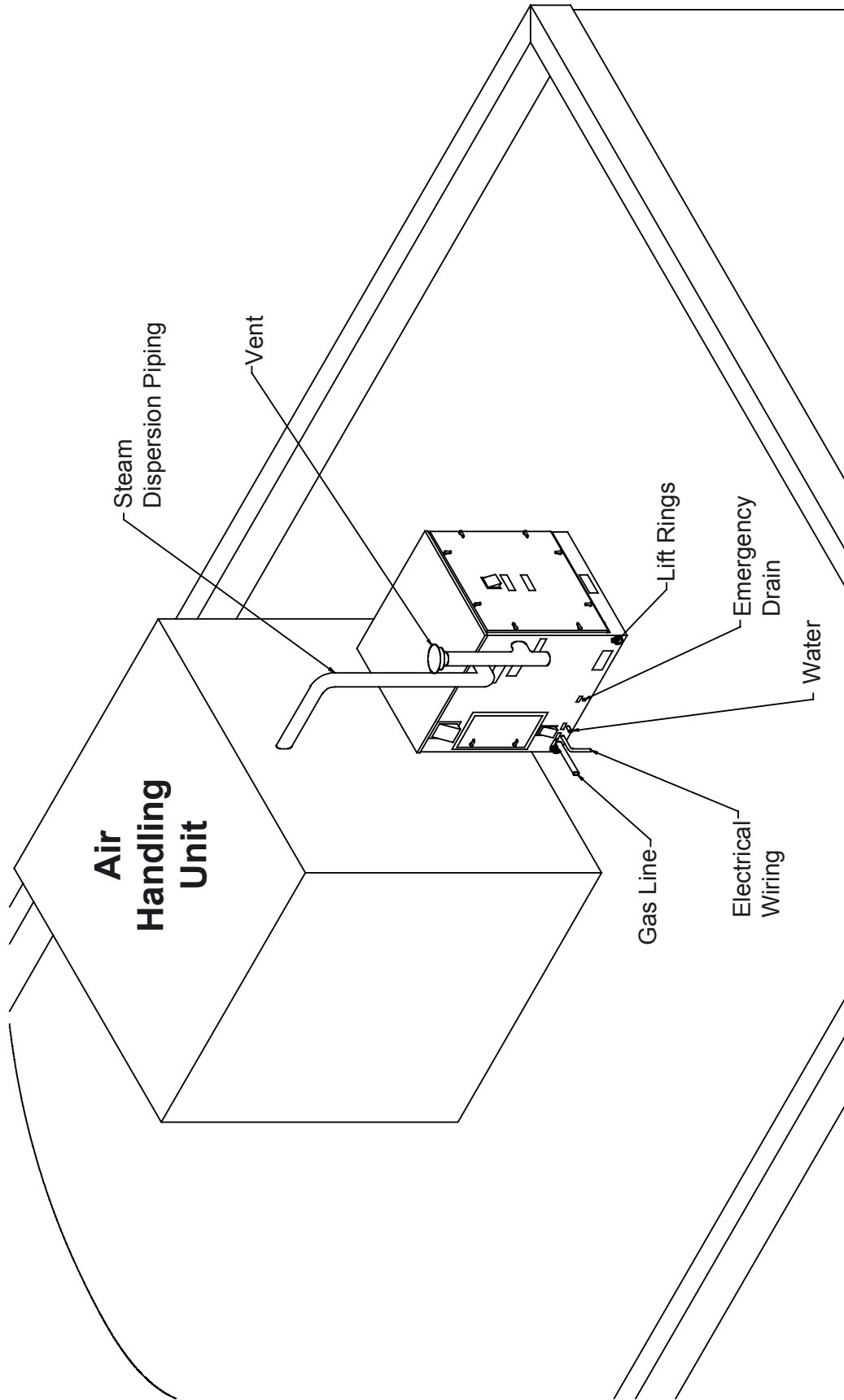

GFHE 150 Outdoor Enclosure

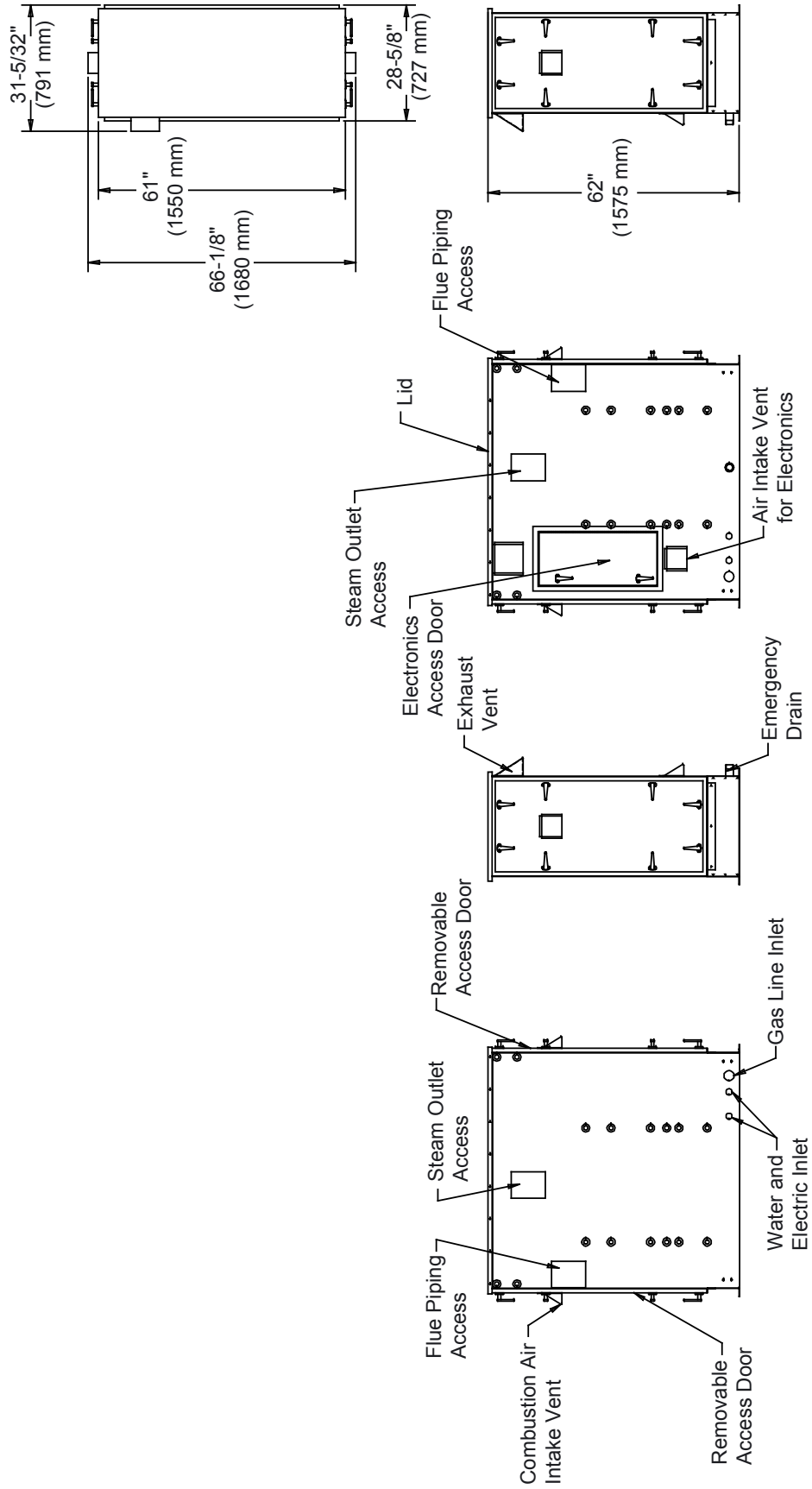

GFHE 300 Outdoor Enclosure

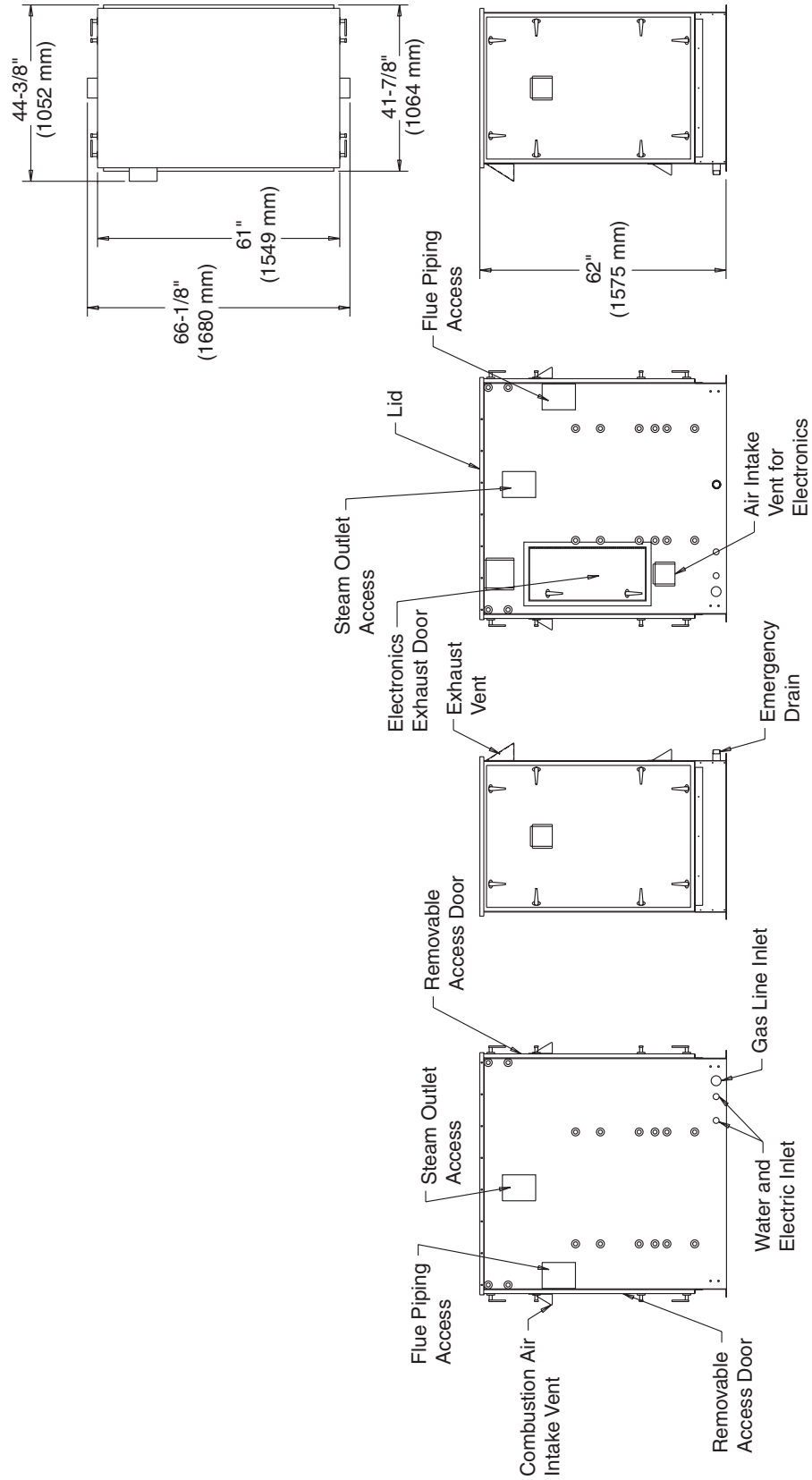

GFHE 450 Outdoor Enclosure

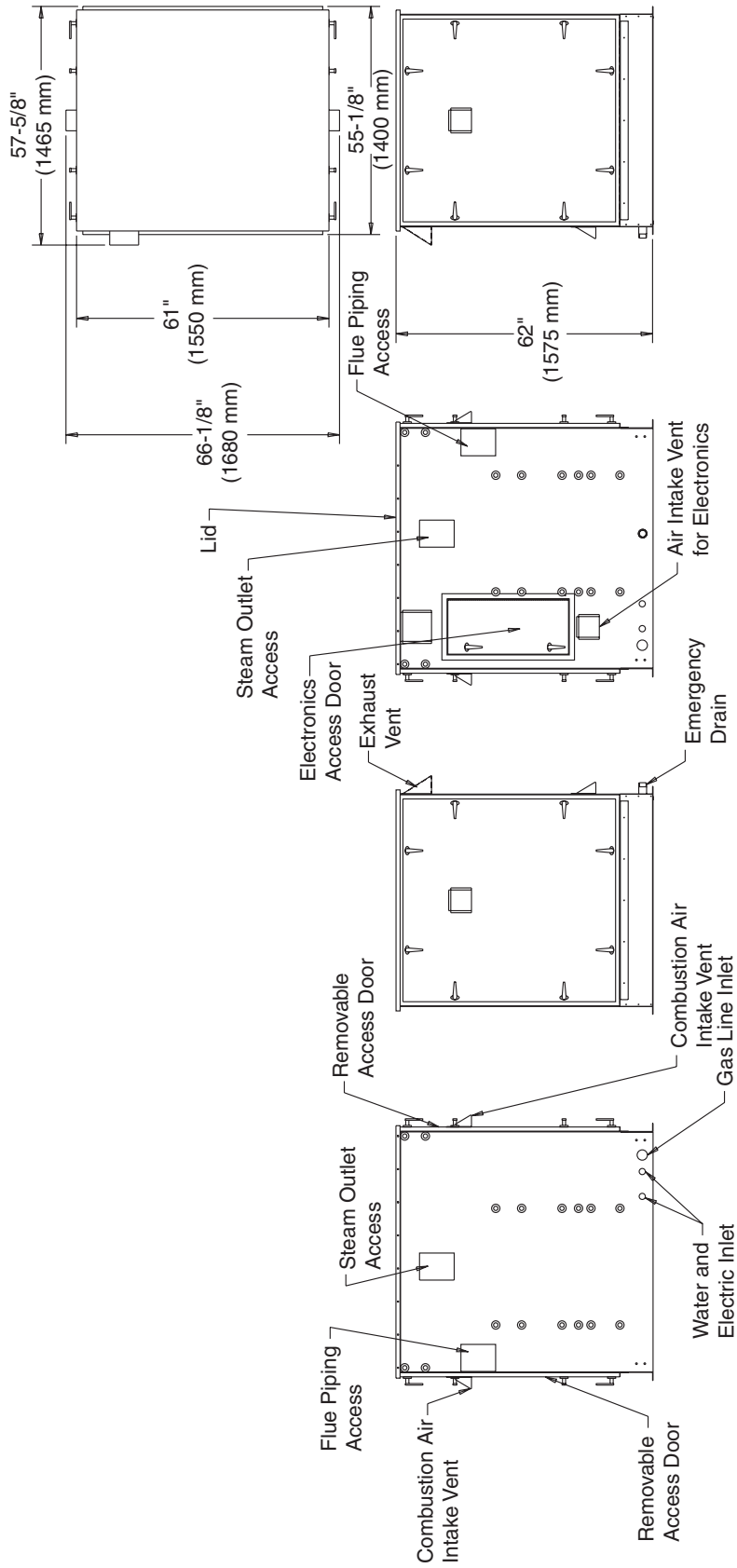

Start Up Procedure

Only qualified personnel should perform start up procedure.

1. Examine the electrical compartment for any loose or disconnected component wiring. Check to make sure all of the control wiring has been completed and been done correctly.
2. Remove the top cover of the unit by unscrewing the screws holding the lid in place. Make sure all of the Ionic Beds are fastened securely to mounting pins. Make sure gasket is in proper position then replace top cover.
3. Check and re-check incoming voltage source and control wiring for proper connections and tightness of connections. Verify the wiring has been done in accordance with local codes and the enclosed wiring diagram.
4. Turn on water and check for leaks.
5. Turn on gas supply and verify that all gas piping has been checked for leaks. (Soapy water is not recommended for use inside the control cabinet.)
6. Make sure access doors and panels are secure.
7. Power up unit at breaker. Verify Steam Generation switch is in "ON" position See Figure 22-1.
8. The unit will begin to fill. When the water level reaches the low level control electrode the unit will perform its precombustion checks.
9. After the precombustion checks are done, the unit will run at 100% for a period of 5 minutes.
10. During this 5 minute period, the burner must be adjusted for proper operation. (100% Burner Output)
11. If the unit is not properly adjusted, the unit may not operate properly.
12. A combustion analyzer capable of detecting the CO2 level of the combustion gasses will be required. Combustion checks will be done at the outlet of the vent pipe of the GFH-150 or the 1/8" NPT plugs on the top of the collection box of the GFH-300 or GFH-450. See Figure 22-3.
13. The target for the CO2 level will be dependent on the type of gas used. If Natural gas is being used, the proper CO2 level will be between 8.5 - 9.5%. For LP operation, the CO2 level will need to be adjusted between 10 - 11%.
14. Turning the adjustment screw in the clockwise direction will decrease the level of CO2, and turning the adjustment screw counter-clockwise will increase the CO2 level.
15. After the unit has been properly adjusted, and the 5 minute warm-up period expires, the unit will go into normal operation.

Figure 22-1

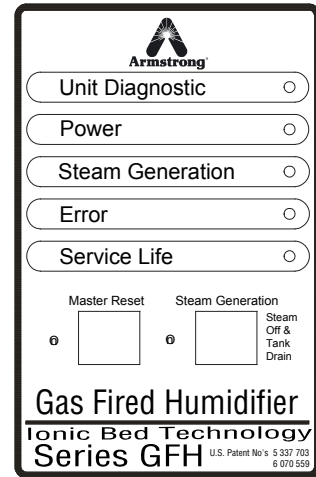

Figure 22-2

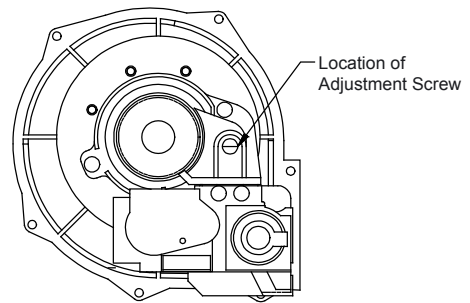
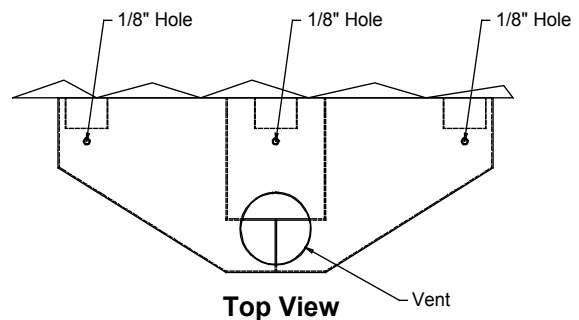

Figure 22-3



Principal of Operation

The Gas Fired HumidiClean humidifier converts ordinary tap water or purified water to steam for distribution to raise the relative humidity level. The demand for humidity is sensed by a humidistat, which sends a control signal to the Gas Fired HumidiClean.

When power is initially supplied to the unit from the circuit breaker, all LEDs will illuminate for 5 seconds. The "POWER" LED will remain on and the unit's fill valve solenoid is energized to allow water to enter the tank at a rate of 3 gal/min. Note: If the water level in the tank is above the low water level when power is applied, the drain valve will be energized to drain the water below the low water level.

Once the water level in the tank has reached the low water switch, the unit will make sure all of its safety circuits are satisfied. The "STEAM GENERATION" LED will then energize, and the unit will initialize its precombustion checks and ignite.

The water fill solenoid continues to be activated until the water level in the tank has energized the high water switch. Note: If fill or drain valves are not energized when power is first applied check display LEDs for diagnostic code. See DIAGNOSTICS section.

The radiant burner will remain on for 5 minutes to preheat the water inside the tank.

After the 5 minute heat-up time, the Gas Fired HumidiClean will continue to produce steam based on the demand signal from the humidistat. If the demand signal drops below 2% or the high limit/sail switch circuit opens, the burner will disengage and the "STEAM GENERATION" LED will turn off. Note: If the humidifier shuts off due to low humidistat demand, a demand signal of 20% or greater is needed to re-light and turn on the "STEAM GENERATION" LED.

The Gas Fired HumidiClean will produce steam continuously and refill the tank with water when the low water level is reached. These fill intervals will be started as defined in the software of the printed circuit board and be shut off by the high water switch.

The PC Board generates a Pulse Width Modulated (PWM) signal and sends this signal to the burner package to achieve a modulating output based on the signal demand from the humidistat.

As the Gas Fired HumidiClean continues to produce steam, the unit will accumulate and memorize the steam generation time for the purpose of defining a drain cycle and service life (this memory is not affected by power outages). When the Gas Fired HumidiClean burner has accumulated the steam generation time set by the drain frequency DIP switch setting, the unit activates the drain solenoid and begins draining the tank. When the water level drops below the low water electrode, the burner will disengage. The printed circuit board controls the drain cycle and can be field modified. See DIP Switch Settings Section. Once the unit has timed out of the drain cycle and all of the switches are still in position to generate steam, the water fill solenoid switch is activated to fill the tank and the cycle starts over again.

Completing a Service Life Cycle

When the 90% of the selected service time has accumulated, the "SERVICE LIFE" LED on the control panel will start to flash (blink on and off). See DIP Switch Settings Section. It will continue to produce steam on demand for the remaining Service Life. During these hours of operation, the Gas Fired HumidiClean will display a flashing "SERVICE LIFE" LED. After 100% of the selected Service Life has accumulated, in hours of steam generation, the unit will shut down by draining the tank as described above and not respond to any call for humidity.

End of Season Drain

If at any time during normal operation there is not a demand for humidity for a continuous 72 hour period, the Gas Fired HumidiClean drains the tank and the PC Board initiates a drying cycle by cycling the heat exchanger for short intervals in order to dry the ionic beds.

If the unit is to be manually shut down for end of season service, the service technician should manually drain the unit by removing the 2" NPT plug from the drip leg of the tank, remove the beds, and physically dry the tank.

Maintenance

Caution: Label all wires prior to disconnection when servicing controls. Wiring errors can cause improper and dangerous operation. Proper operation must be verified after servicing.

When servicing or replacing components, use only Armstrong approved replacement parts. Please contact Armstrong directly, or your local Armstrong Representative for a complete parts list. Any substitution of parts or controls not approved by Armstrong International, Inc. is at the owner's risk.

Recommended Inspection Schedule

The unit should be visually inspected every 30 days of operation for visible problems. A qualified service person should inspect all aspects of the installation at least once a year. The inspection should cover:

1. Vent connector and chimney should be inspected for no blockages.
2. The vent pipe should be inspected for proper pitch and support. All joints of the vent pipe should be inspected to verify there are no leaks.
3. Burner flame should be inspected for visual combustion. The burner will burn blue and orange on the surface of the burner. If the flame is visually inspected and is not in order, please check combustion with a combustion analyzer and adjust burner package as described in the Start-Up Section.

Burner should be checked at least annually when used in areas where high quantities of air borne particles may plug the air passages through the surface matrix. To check for proper field operation of the burner, measure the Carbon Monoxide (CO) level of the flue gasses. If the CO level measured (Insert acceptable level here) in the flue gasses is above acceptable levels the burner system should be serviced. Please refer to Maintenance Section for proper service of Burner Assembly.

4. Verify there are no signs of visual degradation.

Replacing the Ionic Beds

The Gas Fired HumidiClean is designed to be virtually maintenance free. As stated in the PRINCIPLE OF OPERATION section, after the Gas Fired HumidiClean has accumulated 90% of the selected Service Life, in hours of heater on time, the "SERVICE LIFE" LED will flash (blink). At this time the ionic beds in the tank should be replaced. If service is not performed, the unit will continue to operate for the remaining hours before shutting down completely. **Note:** Service Life can be adjusted based on water quality. If Ionic Beds are relatively free of scale deposits or scale is forming on tank walls and heat exchanger because beds are saturated with scale, Please consult the factory for Service Life adjustment procedures.

1. Turn off steam generation switch and allow unit to complete a deep drain.
2. Shut off electrical power at circuit breaker, then close the gas shut-off valve.
3. Caution: Tank will still be quite warm and should be allowed to cool.
4. Disconnect steam distribution piping, unlatch and remove lid.
5. Unsnap ionic beds from support pins and lift them out.
6. Inspect tank drain screen and heat exchanger inside the tank. If the drain screen appears to be building deposits in the screen holes it should be removed and cleaned. Remove any flakes that appear in the bottom of the tank.
7. The heat exchanger should be descaled. This can be accomplished by scraping the scale from the exchanger, or by chemically removing the scale. Muriatic acid can be used, follow manufacturer's instructions on the label of the acid.

8. Armstrong also offers a non-caustic cleaning solution called Rite-Quick. Please contact Armstrong, or your local Armstrong Representative for more information.
9. Install new ionic beds, snapping them into place on the support pins.
10. Be sure lid gasket is lapped over all edges of tank access opening. Replace and secure lid.
11. Turn on power at circuit breaker, then open gas valve.
12. Depress and hold in the reset button for 20 seconds. All the LED's will blink together indicating the accumulated hours memory has been reset to zero. The unit should start to fill. **NOTE:** The accumulated time memory can only be reset to zero when the service LED is blinking or on solid.

Modify the Bed Life Setting

1. Complete the steps for servicing the unit as outlined above.
2. The unit must run for at least an hour.
3. Power the unit down.
4. Set the dip switches to the desired EOL settings. See Page 29 for table of dip switch settings.
5. Power the unit up. The new Bed Life Settings will be set.

Note: If the dip switches are reset prior to the completion of step two, the unit could lock up. The power of LED will be lit, but the unit will not respond to any input. If this is the case, the following steps must be taken to restore the unit to proper operation.

- a. Power the unit down.
- b. Reset the dip switches to the previous settings as recorded (**Factory Defaults** are GFH-150, GFH-300 + GFH-450 = 500 hours).
- c. Power the unit up at breaker.
- d. Press and hold the "RESET" button to reset the EOL time. This must be held for at least 20 seconds.
- e. Allow the unit to run for at least an hour.
- f. Power the unit down at breaker.
- g. Set the dip switches to the desired settings. See Page 29 for the dip switch settings.
- h. Power the unit at breaker.

Cleaning the Water Level Electrodes

1. If there is water in the steam generating tank, turn the Steam Generation switch to off, and completely drain the tank.
2. After the tank has drained, turn off the main power at the disconnect and close the main gas shut-off.

3. Unclamp and remove the 5/8" ID Silicone tubing from the top outlet of the level canister.

4. Disconnect wires from the probes, noting the probe and wire locations. Note: Level control float switches are used for DI, RO, or very pure water. Cleaning should not be required.

5. Unscrew the probes from the level canister using the hex nut fitting on the probe (Note: Level canister bushings may be removed with the probes, if necessary).

6. Use a wire brush, wire wheel, or similar means to clean scale deposits off the stainless steel tip of the probe. Cleaning of the Teflon insulating jacket (white portion) should not be needed.

7. Inspect the interior of the level canister. If large amounts of scale or debris are present, remove the canister from the cabinet by removing the two clamping bracket screws and disconnecting the 5/8" ID Silicone hose at the bottom of the canister. Flush the canister with water to remove debris and reinstall.

Figure 25-1

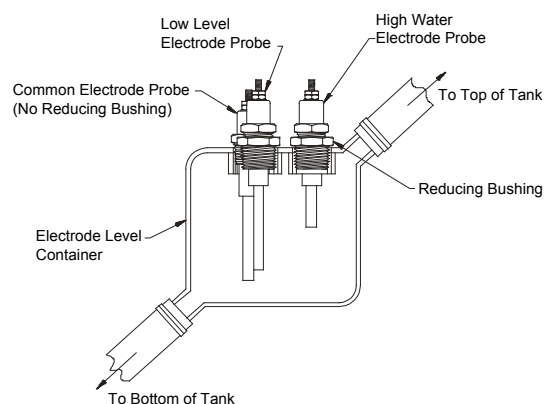

8. Reinstall the probes and probe wires in their proper locations. The high water probe (shortest) goes in the right hole of the canister. The low water probe (medium length) goes in the left front hole of the canister. The common probe (longest) goes in the left, rear hole of the canister.
9. Reconnect the 5/8" ID Silicone hose(s).

Burner / Heat Exchanger Assembly

To check for proper field operation of the ceramic radiant burner, measure the carbon monoxide (CO) of the flue gasses at 100% demand. If the CO level measured in the flue gasses is above acceptable levels (greater than 60 ppm) refer to Figure 22-3 for proper check points, the burner system should be serviced.

1. The blower motor has no lubrication points, therefore motor lubrication is not recommended.
2. Turn the Steam Generation switch to the off position to drain the tank completely.
3. Turn off gas, electricity, and water supply to the unit.
4. Using a vacuum, remove all dust from the control cabinet area, and blower assembly.
5. Disconnect the gas piping going to the gas valve.
6. Disconnect wiring harness to the blower assembly.
7. Unplug wires to blower and pressure switch.
8. Unplug flame detection rod and igniter wires from module.
9. Remove the 4 bolts holding the blower assembly to the heat exchanger and remove the burner assembly.
10. Use a 6" flue brush with a 28" extension and a reversible drill. Work brush in and out of the fire tube. Using a vacuum with an extension, remove deposits from fire tube.
11. To service the burner system, clean both the blower and burner. Remove the blower(s) from the system and clean dust from the fan wheel.
12. Remove the burner for cleaning. Dislodge particulate matter from the burner surface matrix by using compressed air. Keep the air nozzle about 2" from the burner surface blowing straight down on the surface while moving the nozzle back and forth length wise above the surface. This dislodges particles trapped in the matrix by pushing them back inside the burner.
- 13. Avoid blowing air tangentially across the surface since this tends to have a destructive effect to burner surface.**
- 14. WARNING: personnel performing this maintenance should wear appropriate respiratory protection to avoid inhaling loose refractory ceramic fibers.**
15. Allow particulate matter to fall from burner through the air / gas inlet to assist in removing the particulate matter.
16. A vacuum may be used at the air / gas inlet to assist in removing the particulate matter.
17. Re-assemble the burner – blower system.
18. Re-install gasket, and burner assembly into heat exchanger. Inspection of the gasket will be required to determine if old gasket can be used, or should be replaced.
19. Re-connect gas supply line, turn gas on and check for leaks.
20. Re-connect all control wiring
21. Apply power and turn Steam Generation switch to ON position.
22. Verify normal operation outlined in Start-Up Section.

Removing / Replacing Heat Exchanger

1. Turn the Steam Generation switch to the off position to drain the tank completely.
2. Turn off gas, electricity and water supply to the unit.
3. Using a vacuum, remove all dust from the control cabinet area, and blower assembly.
4. Disconnect the gas piping going to the gas valve.
5. Disconnect wiring harness to the blower assembly.
6. Unplug wires to blower and pressure switch.
7. Unplug flame detection rod and igniter wires from module.
8. Remove the 4 bolts holding the blower assembly to the heat exchanger and remove the burner assembly.
9. Disconnect steam distribution piping from lid of unit, and remove lid from unit.
10. Disconnect Vent piping from exhaust nipple, or exhaust collection box.
11. Remove either exhaust nipple or exhaust collection box by removing all the bolts holding it in place. Care should be taken not to damage the gasket.
12. Remove the 12 bolts holding the front of the heat exchanger in place, and remove any additional bolts holding the exhaust end of the heat exchanger in place.
13. Carefully lift the heat exchanger from the steam generation chamber.
14. The new heat exchanger will ship in two gaskets (shipped loose) for the inlet and exhaust connections of the heat exchanger. Remove adhesive strips, and install gaskets on appropriate surfaces of the heat exchanger.
15. Carefully lower the heat exchanger into position in the steam chamber.
16. Install all required bolts into position in both the inlet and exhaust sides of the heat exchanger. In the case of the GFH-150, the exhaust nipple must be installed prior to bolting the exhaust end of the heat exchanger in place.
17. Snug all 12 bolts on the inlet side of the heat exchanger, and all 8 bolts on the exhaust end of the heat exchanger.
18. Using Figure 27-1 torque all bolts to 50 in-lb in the order shown. Using the same torque pattern, continue to torque all the bolts to the final 70 in-lb torque rating.
19. **VERIFY ALL BOLTS GET TORQUED PROPERLY ON BOTH THE INTAKE AND EXHAUST ENDS OF THE HEAT EXCHANGER.**
20. Replace the exhaust collection box. The gasket used between the tank and the exhaust collection box does not have adhesive gasket, so care will have to be taken to make sure the gasket is in proper place.
21. Re-connect the exhaust vent piping to exhaust collection box, or exhaust nipple.
22. Re-install steam chamber lid, and re-connect steam distribution piping.
23. Re-install gasket, and burner assembly into heat exchanger. Inspection of the gasket will be required if old gasket can be used, or should be replaced.
24. Re-connect gas supply line, turn gas on and check for leaks.
25. Re-connect all control wiring.
26. Apply power and turn Steam Generation switch to ON position.
27. Verify normal operation outlined in Start-Up Section.

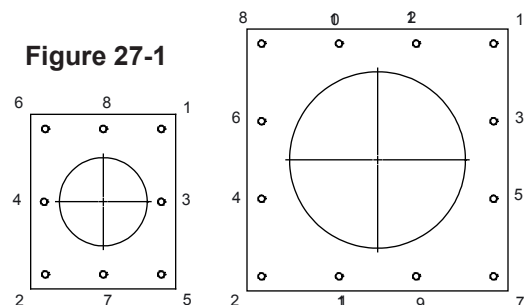

Troubleshooting

Diagnostics

There are some diagnostic routines programmed into the PC board. If these routines detect a problem the unit will shut down and flash the "ERROR" LED a certain number of times, followed by a long pause.

Power	Steam Generator	Error	Service Life	LED #5	Definition
S					Unit operational and is filling, draining or has no call for demand.
S					Unit is operating and the gas is on.
S		B	S		High humidity/sail switch is open, will not operate until closed.
S			B		Unit has run for over 90% of bed life, will operate until 100%.
S			S		Unit has accumulated 100% of bed life, will not operate until reset.
S		1B			Fill timeout to low level during initial fall.
S		2B			Water level drop below low level during basic operation.
S		3B			Fill timeout from low to high level.
S		4B			Water level above high level timeout.
S		5B			Illegal switch state.
S		6B / 7B / 8B			Ignition burner #1 error / ignition burner #2 error / ignition burner #3 error.
S		9B			Low level not dropped below during empty drain.
S		10B / 11B / 12B			Blower/burner #1 error / blower/burner #2 error / blower/burner #3 error.
S		13B			Safety low probe open.
		14B			Pressure switch error.
		15B			E ² Error Corrupted Software
		16B			Aqua Stat Error
					Power dropped out.*

S - Solid On

B - Blinking On (Flashing)

1 Blink - The low level switch did not close in set fill time.

Check - Defective fill valve, debris in fill valve inlet screen or line to level container, water leakage from tank or tubing, low or no water pressure, drain valve stuck open or leaking, defective low water level switch (electrodes need cleaning).

2 Blinks - The low level switch has not closed in 3 minutes of fill cycle time.

Check - Debris in fill valve, no water flow or low water pressure, drain valve leaking or stuck open, defective low water switch (electrodes need cleaning).

3 Blinks - The high level switch did not close by completion of initial fill.

Check - Defective fill valve, debris in fill valve inlet screen or line to level container, water leakage from tank or tubing, low or no water pressure, drain valve stuck open or leaking, defective low water level switch (electrodes need cleaning).

4 Blinks - The high water switch is still closed 5 minutes after hitting high level.

Check - Fill valve stuck open, defective high level switch, debris in level container.

5 Blinks - The high level switch is closed and the low level switch is open.

Check - Defective level switch(es), loose wire to level switches, scale on electrodes.

6 Blinks / 7 Blinks / 8 Blinks - Ignition burner #1 error / Ignition burner #2 error / Ignition burner #3 error

Check - Gas may be turned off to the unit, defective igniter, loose wire from ignition module to igniter or flame sensing rod. (Only applies to units with software GFH150.HEX, GFH300.HEX, GFH450.HEX)

9 Blinks - The low level switch has not opened after a set drain.

Check - Defective low level switch, defective drain valve, debris in level container tubing or drain valve.

10 Blink / 11 Blink / 12 Blink - The blower/burner #1/#2/#3 is not operating.

Check - No power to blower, loose wire to blower, or loss of tach signal.

13 Blinks - The safety low probe is open.

Check - Defective low water level switch, electrodes need cleaning, loose wire to probe, debris in level container.

14 Blinks - The exhaust pressure switch is open.

Check - Blocked exhaust flue, loose wire to pressure switch

15 Blinks - E² Error - corrupted software data.

Check - Reset unit, regenerate power. Reset E²

16 Blinks - Aquastat error, stuck open.

Check - For loose or disconnected wire to aquastat setting is too high.

***Power loss to unit due to stack over temperature situation -** The over temperature module cuts out.

Check - For low water situation, level control electrodes for scale buildup, loose or disconnected wire from probe to module.

Clearing Error Codes

After troubleshooting, the error state must be cleared by depressing the reset button for 10 seconds. All the LED's will then flash. Release the reset button and the unit should resume normal operation (it will fill or drain to get to the low level switch then fill to the high and begin boiling). Turning the unit on and off will not clear most of the error states.

White-Rogers Gas Control Board Diagnostics

When the unit experiences a burner error the White Rogers board will show blink code in the bottom left hand corner of the board in the form of a red LED. The blink code will only show for 2 minutes after the unit has gone into error. Each flash will last 0.25 seconds and each pause will last approximately 2 seconds.

- 1 Flash, then pauseSystem lockout
 - 2 Flashes, then pausePressure switch stuck closed
 - 3 Flashes, then pausePressure switch stuck open
 - 6 Flashes, then pause 115 Volt AC power reversed
 - 7 Flashes, then pauseLow flame sense signal
 - 8 Flashes, then pauseCheck igniter or improper grounding
 - Continuous flashing, (no pause).....Flame has been sensed when no flame should be present (no call for heat)
- The LED will also flash once at power-up.

Dip Switch Settings / Jumpers / Toggle Switches

There is a bank of DIP switches on the top edge of the PC board. The drain frequency and duration (drain time) and the Service Life time setting can be modified. Several other parameters are also adjustable. The main power must be turned off before the DIP switches are changed. See chart below for a complete listing of DIP switch settings. Please consult factory if unsure regarding any DIP switch setting. See Fig. 16-1 on page 16 for locations.

Table 29-1. Circuit Board Dip Switch Settings					
Dip Switch 1		Parameter			
Drain On Time		2 Min.	5 Mins.	10 Mins.	15 Mins.
SB1-1 (2)	Drain Time	Not Used			
SB1-2 (1)		Off	Off	On	On
SB1-3 (0)		Off	On	Off	On
End Of Life		500 Hrs.	1000 Hrs.	2000 Hrs.	3000 Hrs.
SB1-4 (2)	End of Life	Not Used			
SB1-5 (1)		Off	Off	On	On
SB1-6 (0)		Off	On	Off	On
Drain Frequency		1 Hr.	4 Hrs.	12 Hrs.	24 Hrs.
SB1-7 (2)	Drain Frequency	Not Used			
SB1-8 (1)		Off	Off	On	On
SB1-9 (0)		Off	On	Off	On
Dip Switch 2		Parameter			
DS / Keypad					
SB2-1	Keypad	Not Used			
Production Test					
SB2-2	Test / Run	Off = Run	On = Test		
SB2-3	Prod Test / Run	Off = Run	On = Test		
Comm. Address					
SB2-4 (1)	Comm Address	Not Used			
SB2-5 (0)		Not Used			
D/A Scale					
SB2-6 (2)	D/A Scale 2	Not Used			
SB2-7 (1)	D/A Scale 1	Not Used			
Voltage Source (J2)					
5 Vdc	Supplies 5 Vdc to Voltage Source terminal on low voltage term. strip				
24 VAC	Supplies 24 VAC to Voltage Source terminal on low voltage term. strip				
12 VAC	Supplies 12 VAC to Voltage Source terminal on low voltage term. strip				
Stat Input		Set Jumper According to Stat Input			
J3	1.9 - 3.9 Vdc Stat Input				
J4	4 - 20 mA Stat Input				
J5	0 - 5 Vdc Stat Input				
J6	0 - 10 Vdc Stat Input				
Manual Switches		Manual Switch Actuates: (Normal position is Up, Down to Activate)			
SW-1	Fill Valve				
SW-2	Drain Valve				
SW-3	Temper Valve (Not Used)				

115V System Ladder Schematic

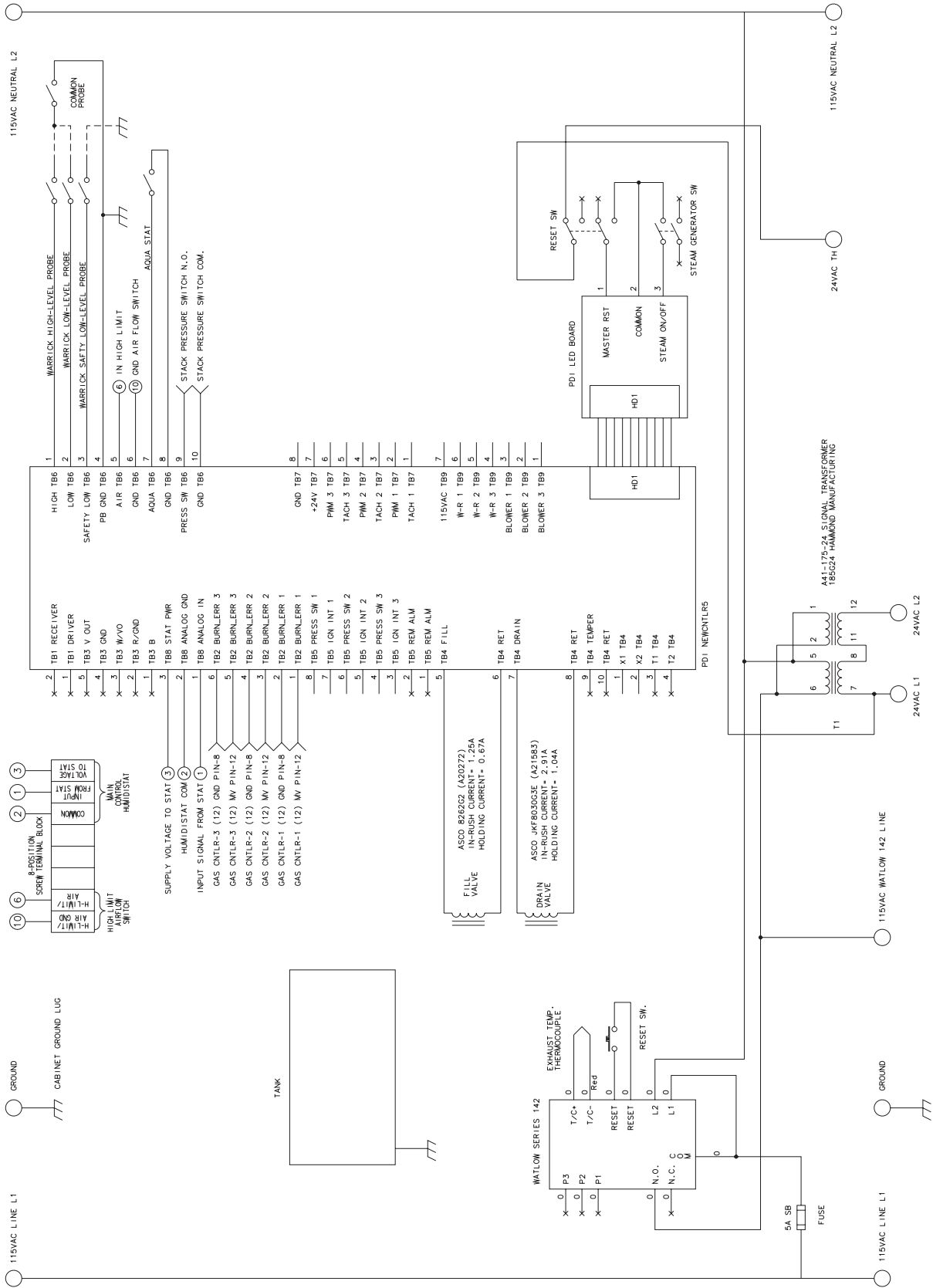

Outdoor Enclosure Units System Wiring Schematic

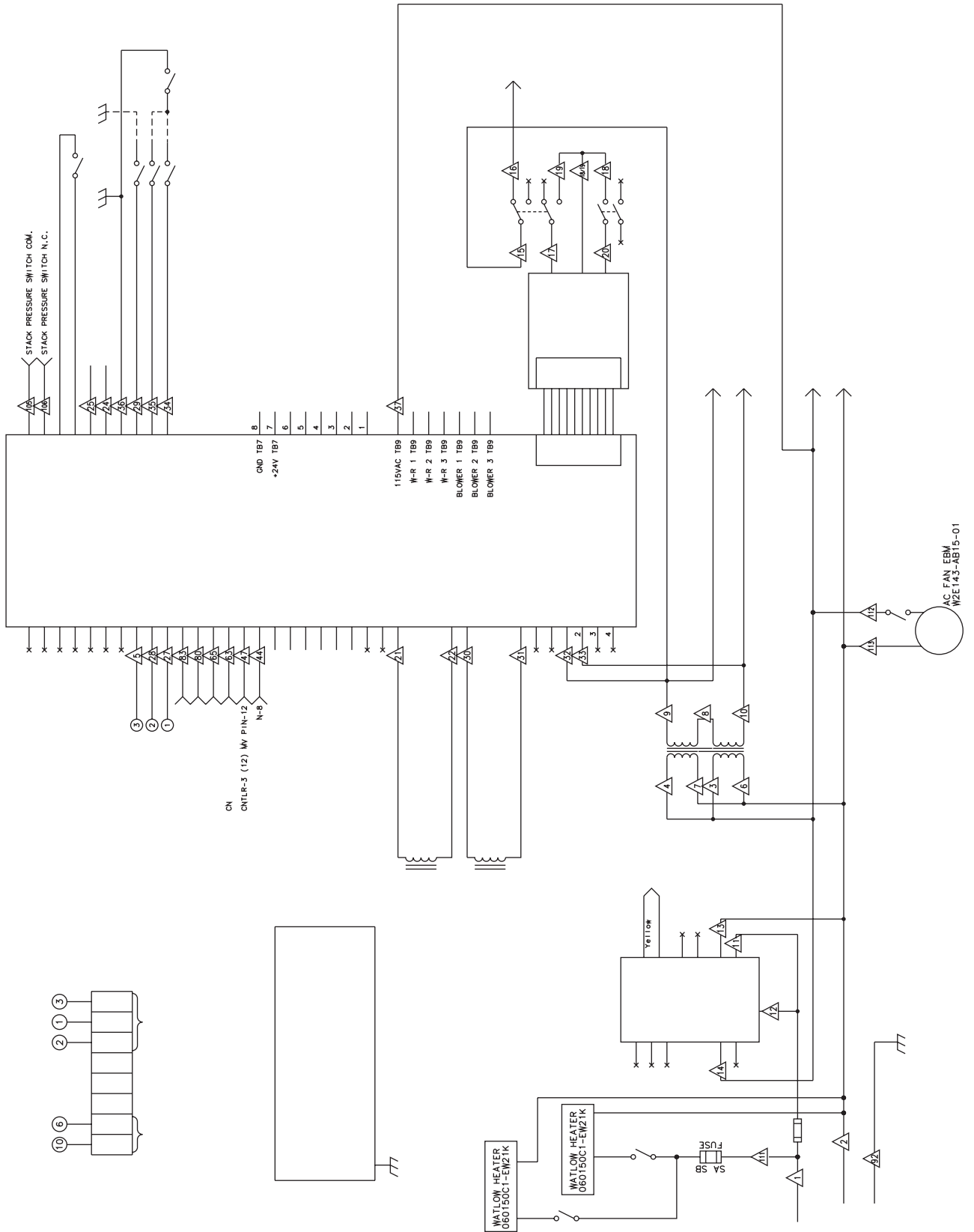

System Wiring Schematic

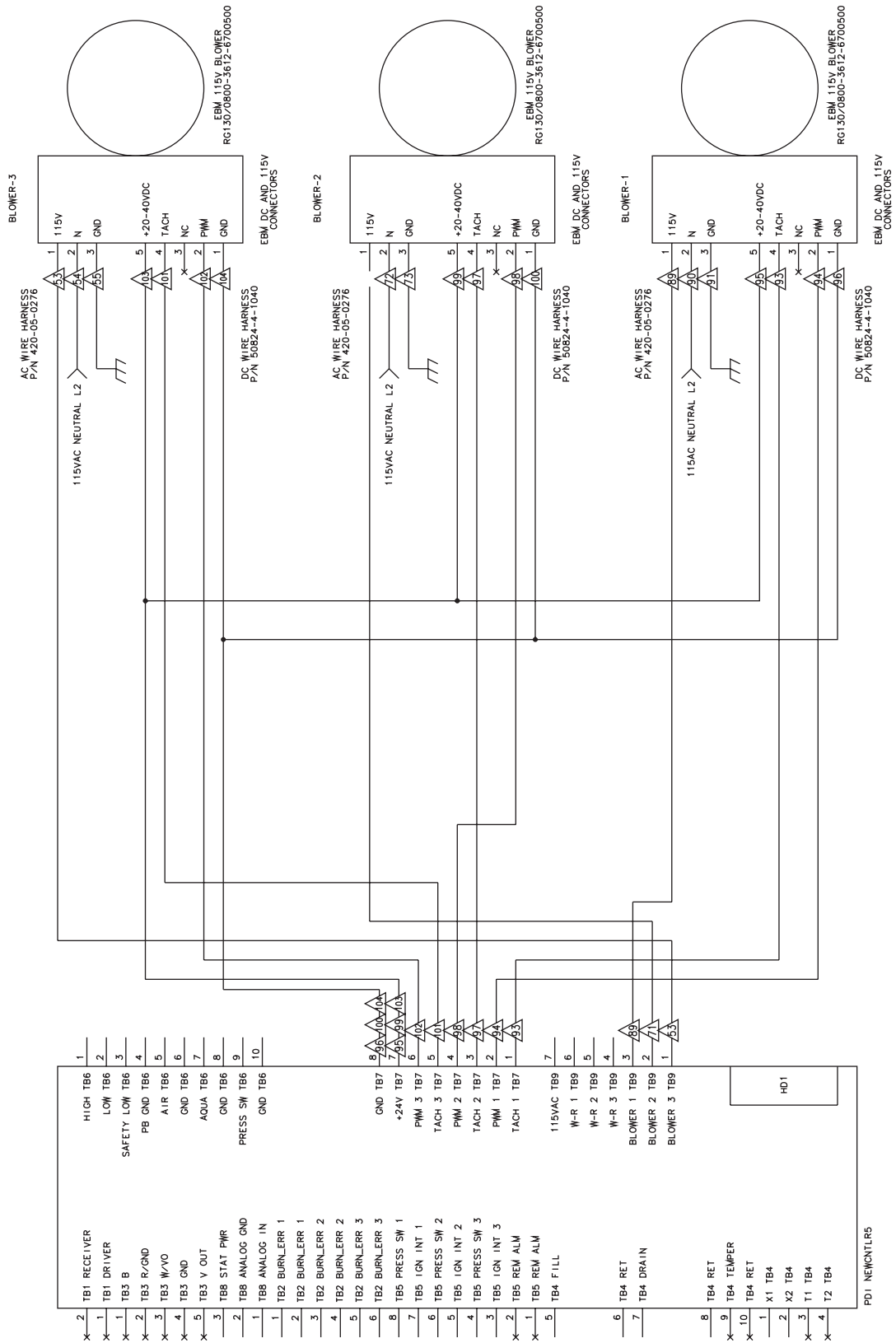

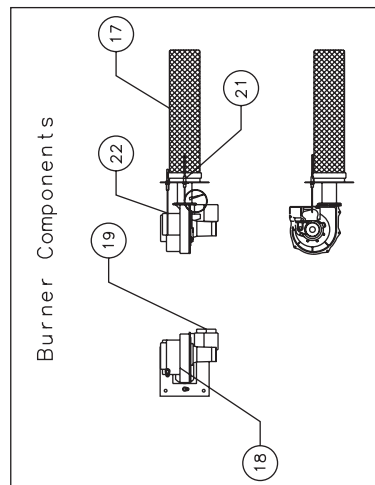
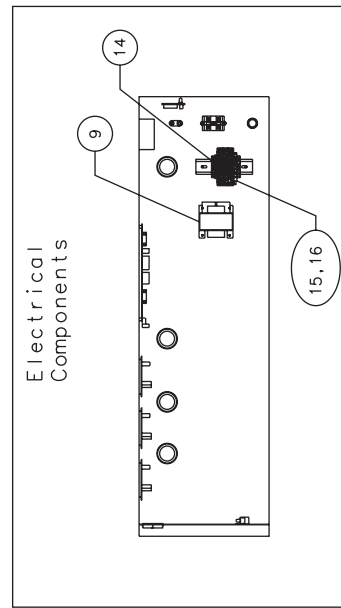
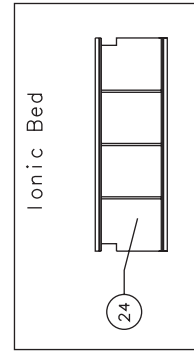
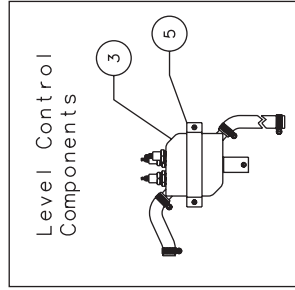
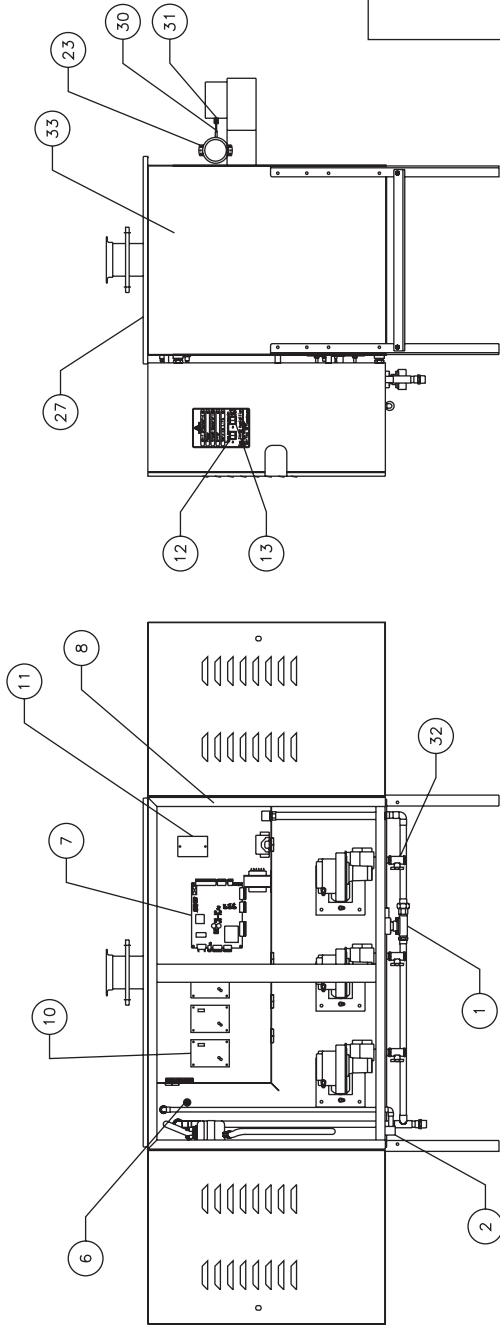

GFH Series Gas Fired HumidiClean Parts List

Item Number	Part Number	Description
1	A21583	Drain Valve
2	A21582	Fill Valve
3	C4559	Liquid Level Canister
4	B5139	Float Switch - DI
5	B5135	Bracket, Liquid Level
6	B2960	Low Level Safety Probe
7	C5389	PC Board w/Stand-Offs
8	B5140	LED Board
9	B6624	Transformer 120/240v
10	C5379	Ignition Control Module
11	A22908	Over Temperature Board
12	A9012	Reset Rocker Switch
13	A9104	On/Off Rocker Switch
14	B2414-3	Terminal Block
15	A8649	Fuse Block
16	A10718	3 AMP Fuse
17	A22460	Burner Assembly Repair Kit
18	A22459	Blower Repair Kit
19a	A22457	Gas Valve Assy w/ Gasket (Natural)
19b	A22458	Gas Valve Assy w/ Gasket (Propane)
20	C5379	Ignition Control Module
21	A22449	Flame Detection Rod Repair Kit
22	A22450	Surface Igniter Repair Kit
23	A22053	Blower Pressure Switch
24	C5120	Ionic Bed
25	D3824	Lid Gasket - Front - GFH-150
	D3825	Lid Gasket - Front - GFH-300
	D3826	Lid Gasket - Front - GFH-450
26	D3827	Lid Gasket Side - All Units
27	A21998	Exhaust Gas Thermocouple
28	A22027	Gasket Thermocouple
29	A22055	1/2" NPT Manual Gas Valve
30	C5437	Sealed Combustion Kit for GFH-150
	C5432	Sealed Combustion Kit for GFH-300
	C5433	Sealed Combustion Kit for GFH-450
31	D4463	Heat Exchanger for GFH units (Need C5803 and C5804 Gaskets)

Armstrong International, Inc. Limited Warranty and Remedy

Armstrong International, Inc. (Armstrong) warrants to the original user of those products supplied by it and used in the service and in the manner for which they are intended, that such products shall be free from defects in material and workmanship for a period of one (1) year from the date of installation, but not longer than 15 months from the date of shipment from the factory, [unless a Special Warranty Period applies, as listed below]. This warranty does not extend to any product that has been subject to misuse, neglect or alteration after shipment from the Armstrong factory. Except as may be expressly provided in a written agreement between Armstrong and the user, which is signed by both parties, Armstrong **DOES NOT MAKE ANY OTHER REPRESENTATIONS OR WARRANTIES, EXPRESS OR IMPLIED, INCLUDING, BUT NOT LIMITED TO, ANY IMPLIED WARRANTY OF MERCHANTABILITY OR ANY IMPLIED WARRANTY OF FITNESS FOR A PARTICULAR PURPOSE.**

The sole and exclusive remedy with respect to the above limited warranty or with respect to any other claim relating to the products or to defects or any condition or use of the products supplied by Armstrong, however caused, and whether such claim is based upon warranty, contract, negligence, strict liability, or any other basis or theory, is limited to Armstrong s repair or replacement of the part or product, excluding any labor or any other cost to remove or install said part or product, or at Armstrong s option, to repayment of the purchase price. As a condition of enforcing any rights or remedies relating to Armstrong products, notice of any warranty or other claim relating to the products must be given in writing to Armstrong: (i) within 30 days of last day of the applicable warranty period, or (ii) within 30 days of the date of the manifestation of the condition or occurrence giving rise to the claim, whichever is earlier. **IN NO EVENT SHALL ARMSTRONG BE LIABLE FOR SPECIAL, DIRECT, INDIRECT, INCIDENTAL OR CONSEQUENTIAL DAMAGES, INCLUDING, BUT NOT LIMITED TO, LOSS OF USE OR PROFITS OR INTERRUPTION OF BUSINESS.** The Limited Warranty and Remedy terms herein apply notwithstanding any contrary terms in any purchase order or form submitted or issued by any user, purchaser, or third party and all such contrary terms shall be deemed rejected by Armstrong.

Special Warranty Periods are as follows:

Series EHU-700 Electric Steam Humidifier, Series HC-4000 HumidiClean Humidifier and GFH Gas Fired Humidifier with Ionic Beds:

Two (2) years after installation, but not longer than 27 months after shipment from Armstrong s factory.



Armstrong Humidification Group

816 Maple Street, P.O. Box 408, Three Rivers, Michigan 49093 - USA Ph: (269) 273-1415 Fax: (269) 273-9500

Steam Traps \ Humidifiers \ Steam Coils \ Valves \ Air Vents \ Pumping Traps \ Water Heaters
armstronginternational.com