

# DIMENSIONS & DATA CERTIFIED FOR:

Representative:

Order:

Customer:

Order:

Project:

Requirements:

By:

Date:

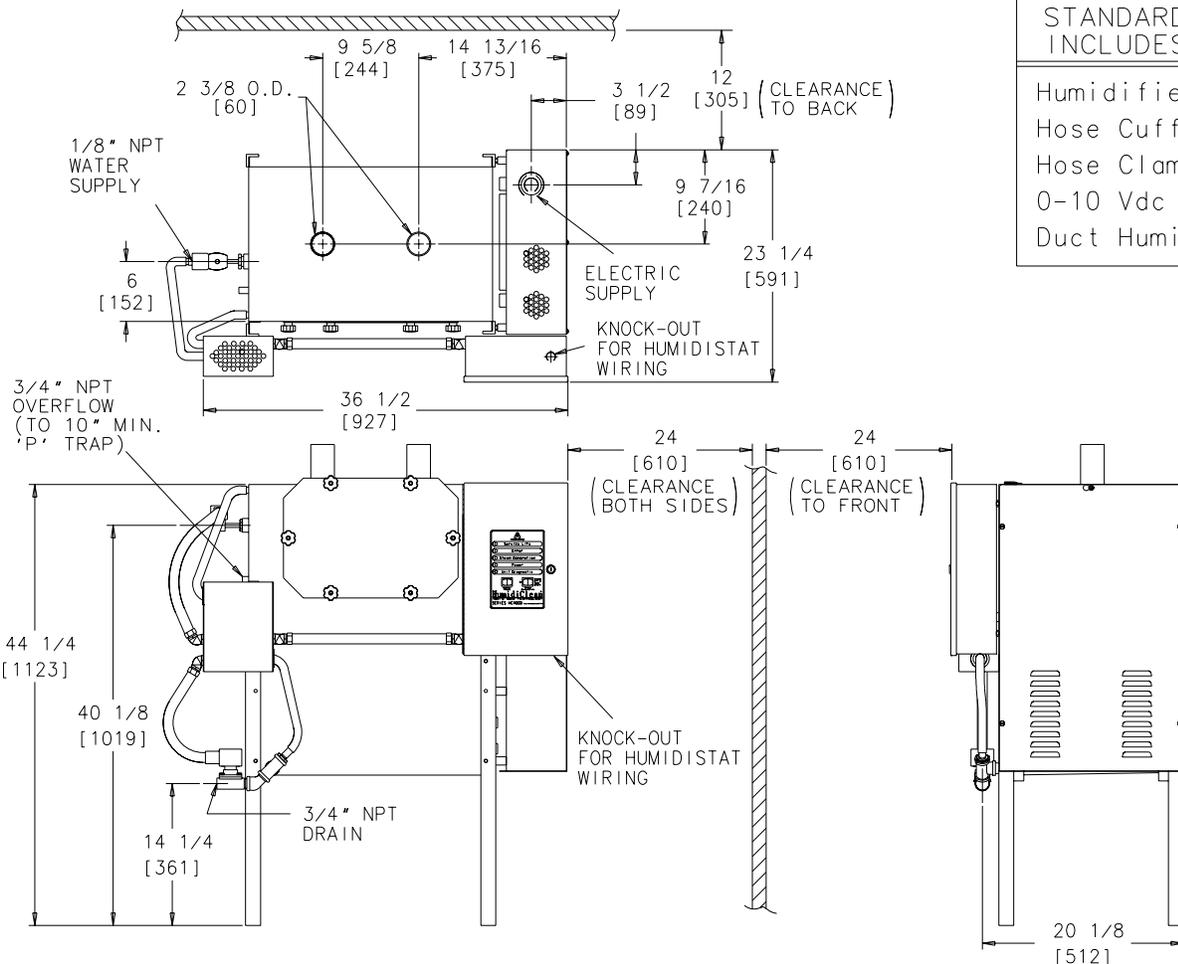

STANDARD PACKAGE INCLUDES:

Humidifier W/ Legs  
Hose Cuffs  
Hose Clamps  
0-10 Vdc Room or Duct Humidistat

## LIST OF MATERIALS

## OPTIONS AVAILABLE:

Generator Tank	T304 Stainless Steel
Cabinet	16 Ga. Steel
Cabinet Finish	Powder Coated Epoxy Enamel
Elements	Incoloy Sheathed, Std. or for DI/RO, T316 S.S.
Ionic Bed Module	Inert Fiber *
Ionic Bed Frame	T304 Stainless Steel *
Hose Cuffs	EPDM Rubber
Dispersion Tube	18-8 Stainless Steel
Tank Gasket	Closed Cell Silicone

Dwyer Duct Pressure Switch  
0-135 OHM Humidistat  
ON-OFF Control Humidistat  
1.9 to 3.9 Vdc Control Humidistat  
ON-OFF High Limit Humidistat  
Modulating High Limit Humidistat  
Remote Indicator Panel of H-fier Status  
Temp-r-Drain  
EHF III Fan Package (2 reqd.)

  
 Armstrong International, Inc.  
 Three Rivers Division  
 Three Rivers, MI 49093  
**Armstrong** (616) 273-1415 Fax(616) 278-6555  
 Posted on Armstrong's homepage [www.armstrong-intl.com](http://www.armstrong-intl.com)

\* NOT USED IN DI/RO APPLICATIONS

HC4500 Weight;  
Approx. Shipping - 175 lbs./80 kg.  
Max. Operating (full) - 370 lbs./172 kg.  
EHF III Fan Package - 33 lbs./15 kg.

Product	CD No.	Date
HUMIDICLEAN SERIES 4500	1125	8-12-99
		Rev. A

# STEAM CAPACITIES & NOMINAL AMP RATINGS

VOLTS	30 Kw Unit		33.5 Kw Unit		40 Kw Unit		45 Kw Unit		48 Kw Unit		50.3 Kw Unit		60 Kw Unit		72 Kw Unit	
	Nom. Amps	Steam Output lbs/hr [kg]/hr	Nom. Amps	Steam Output lbs/hr [kg]/hr	Nom. Amps	Steam Output lbs/hr [kg]/hr	Nom. Amps	Steam Output lbs/hr [kg]/hr	Nom. Amps	Steam Output lbs/hr [kg]/hr	Nom. Amps	Steam Output lbs/hr [kg]/hr	Nom. Amps	Steam Output lbs/hr [kg]/hr	Nom. Amps	Steam Output lbs/hr [kg]/hr
208	84	90[41]	-	-	-	-	-	-	-	-	-	-	-	-	-	-
208	-	-	-	-	-	-	125	135[61]	-	-	-	-	-	-	-	-
240	-	-	-	-	96	120[54]	-	-	-	-	-	-	-	-	-	-
240	-	-	-	-	-	-	-	-	-	-	-	-	144	180[82]	-	-
380	-	-	51	100[45]	-	-	-	-	-	-	-	-	-	-	-	-
380	-	-	-	-	-	-	-	-	-	77	150[68]	-	-	-	-	-
380	-	-	-	-	-	-	-	-	73	144[65]	-	-	-	-	-	-
380	-	-	-	-	-	-	-	-	-	-	-	-	-	-	110	216[98]
480	-	-	-	-	-	-	-	-	58	144[65]	-	-	-	-	-	-
480	-	-	-	-	-	-	-	-	-	-	-	-	-	-	87	216[98]
600	-	-	-	-	-	-	-	-	47	144[65]	-	-	-	-	-	-
600	-	-	-	-	-	-	-	-	-	-	-	-	-	-	70	216[98]

RECOMMENDED BRANCH CIRCUITS		
Nominal Amp Rating	Wire (Gage)	Circuit Breaker
1-12	14	15
13-15	12	20
16-20	10	25
21-24	10	30
25-32	8	40
33-40	8	50
41-48	6	60
49-64	4	80
65-80	3	100
81-100	1	125
101-120	0	150
121-140	00	175
141-160	000	200

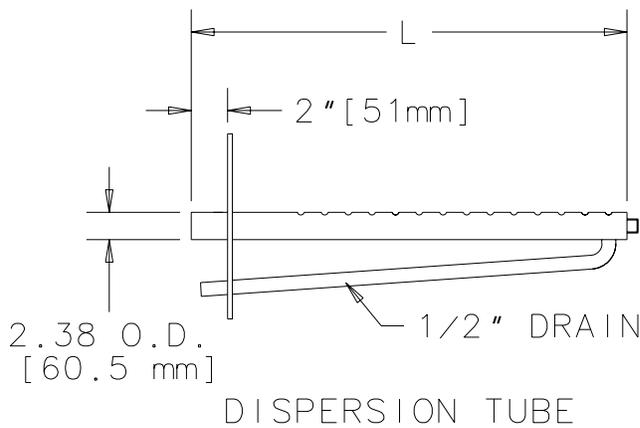

### SELECTING PROPER DISPERSION TUBE

Model No. HC4500 & HC4500DI	Length L [cm]	Duct Width		Weight lbs.[kg]
		Min.	Max.	
DL-1	12" [30]	11" [28]	16" [41]	3 [1.4]
DL-1.5	18" [46]	17" [43]	22" [56]	3 [1.4]
DL-2	24" [61]	23" [58]	34" [86]	4 [2]
DL-3	36" [91]	35" [89]	46" [117]	6 [3]
DL-4	48" [122]	47" [119]	58" [147]	8 [3.6]
DL-5	60" [152]	59" [150]	70" [178]	9 [4]
DL-6	72" [183]	71" [180]	82" [208]	10 [4.5]
DL-7	84" [213]	83" [211]	94" [239]	11 [5]
DL-8	96" [244]	95" [241]	106" [269]	12 [5.5]
DL-9	108" [274]	107" [272]	118" [300]	13 [6]
DL-10	120" [305]	119" [302]	130" [330]	14 [6.4]

Armstrong International, Inc.  
Three Rivers Division  
Three Rivers, MI 49093  
(616)273-1415 Fax(616)278-6555

Product	CD No.	Date
HUMIDICLEAN SERIES 4500 (cont'd)	1125	8-17-99
		Rev. A