

KUNKLE SAFETY AND RELIEF PRODUCTS
TECHNICAL REFERENCE

Technical Reference for Safety and Relief Products

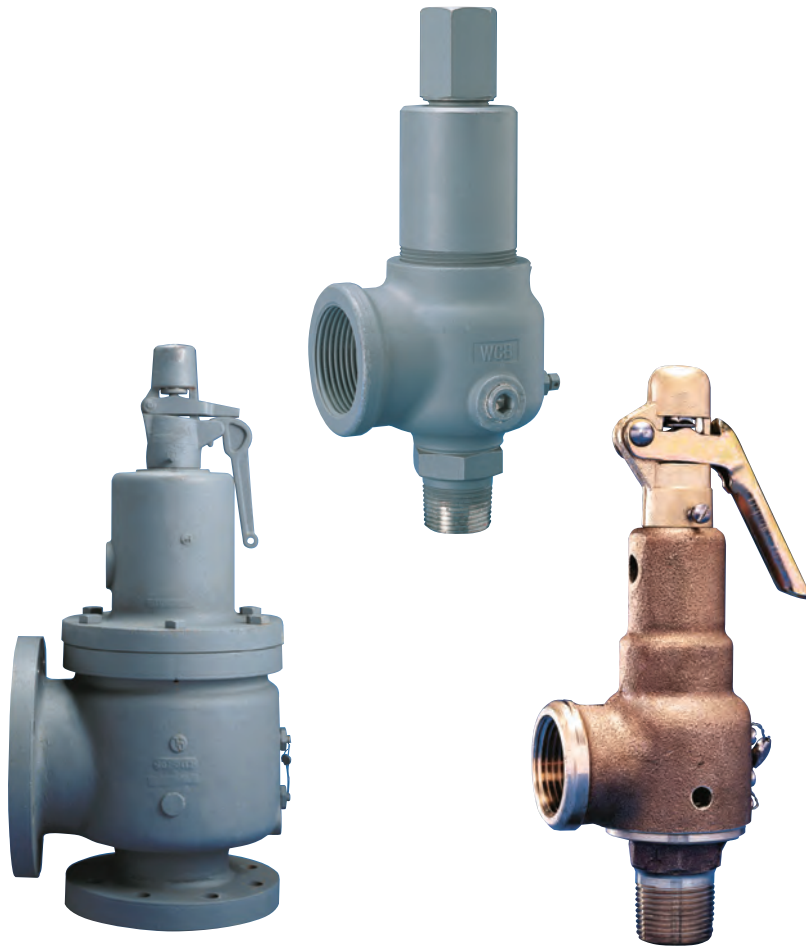

Contents

Definitions and Commonly Used Terms3

ASME Codes4

ASME Code Requirements5

General Safety and Relief Valve Information6

Safety and Relief Valve Pointers7

Safety and Relief Valve Principles of Operation8-9

Ordering Information9

Valve Selection10

Valve Selection Guide11-13

Valve Sizing Overview and Coefficient Method14

Sizing Formulas15

Sizing Coefficient Method16

Sizing Table A17

Sizing Table B18-19

Sizing Table C and D20

Physical Properties21-25

Conversion Factors.....26-27

Installation28-29

Maintenance30

Guarantee30

Terms and Conditions of Sale31-32

Definitions and Commonly Used Terms

A.S.M.E.

American Society of Mechanical Engineers.

A.P.I.

American Petroleum Institute

PRV

Relief Valve, Safety Valve, Safety Relief Valve.

Back Pressure

The pressure that exists at the outlet of a pressure relief device as a result of the pressure in the discharge system. It is the sum of the superimposed and built-up back pressures.

Built-up Back Pressure

The increase in pressure in the discharge header that develops as a result of flow after the pressure relief device opens.

Blowdown

The difference in pressure between the opening pressure and reclose pressure. May be expressed in percent of set pressure or "psig."

Body/Nozzle/Seat

The stationary seating surface, the inlet.

Cap

The pressure screw cover and/or lever housing. May be screwed, bolted, packed, or plain lever.

Chatter

Abnormal, rapid reciprocating movement of the disc on the seat of a pressure relief valve.

Coefficient of Discharge

The ratio of the measured relieving capacity to the theoretical relieving capacity.

Disc

The moveable seating surface.

Gag

A device attached to a safety or safety relief valve that prevents it from opening at the set pressure.

Guide

That portion of the valve used to guide the disc.

Lift

The distance between the seat and disc seating surfaces when the valve is in the full open position.

MAWP

Maximum allowable working pressure. This data is found on the pressure vessel nameplate and is the maximum pressure at which the lowest set safety valve must be set (stamped).

N.B.

National Board of Boiler and Pressure Vessel Inspectors.

Operating Pressure

The gauge pressure at which a pressure vessel is maintained in normal operation. The operating pressure should not be in excess of 90 percent of the PRV set pressure.

Accumulation

The permitted increase in pressure developed after the valve has opened. Usually expressed in percentage, maximum allowable accumulations are established by applicable codes for operating and fire contingencies.

Pre-open/Warn

An audible or visual discharge at a pressure slightly lower than the set pressure. Warns the operator that the valve is about to operate.

Pressure Relief Device

A device actuated by inlet static pressure and designed to open during an emergency or abnormal condition to prevent a rise of internal fluid pressure in excess of a specified value. The device may also be designed to prevent excessive internal vacuum. The device may be a pressure relief valve, a non-reclosing pressure relief device, or a vacuum relief valve.

psia

Pounds per square inch absolute or absolute pressure. Absolute pressure is equal to gauge pressure plus atmospheric pressure [14.7 psi [1.01 barg] at sea level].

psig

Pounds per square inch gauge or gauge pressure. Differential pressure across the valve, equal to absolute pressure inside the pressure vessel minus atmospheric pressure [14.7 psi [1.01 barg] at sea level].

Relief Valve

A spring-loaded pressure relief valve actuated by the static pressure upstream of the valve. The valve opens normally in proportion to the pressure increase over the opening pressure. A relief valve is used primarily with incompressible fluids (liquids).

Safety Relief Valve

A spring-loaded pressure relief valve that may be used as either a safety or relief valve depending on the application.

Safety Valve

A spring-loaded pressure relief valve actuated by the static pressure upstream of the valve and characterized by rapid opening or pop action. A safety valve is normally used with compressible fluids.

Set Pressure

The gauge pressure at which a safety valve visibly and audibly opens or at which a relief valve discharges a 1" long unbroken stream of liquid.

Spindle/Stem

The rod connecting to the disc.

Stamped Capacity

The rated relieving capacity that appears on the device nameplate. The stamped capacity is based on the set pressure or burst pressure plus the allowable overpressure for compressible fluids and the differential pressure for incompressible fluids.

Superimposed Back Pressure

The static pressure that exists at the outlet of a pressure relief device at the time the device is required to operate. It is the result of pressure in the discharge system coming from other sources and may be constant or variable.

Warn Ring or Regulator Ring

The control ring which surrounds the seat, used to control preopen and blowdown.

Yoke/Bonnet

The portion of a safety/relief valve that surrounds the spring; the spring housing.

ASME Codes

The ASME (American Society of Mechanical Engineers) boiler and pressure vessels code requirements for overpressure protection as they relate to Kunkle products is as follows:

ASME Section I

This code applies to boilers where steam or other vapor is generated at a pressure of 15 psig [1.03 barg] or greater and high temperature water boilers intended for operation at pressures exceeding 160 psig [11.03 barg] and/or temperatures exceeding 250°F [121°C].

Boiler Pressure Accumulation

No more than 6 percent above the highest pressure at which any valve is set, or no more than 6 percent above MAWP.

Set Pressure

The set pressure of a one valve installation cannot be higher than the MAWP. The set pressure of the second or other valves in a multiple valve installation can be up to 3 percent above the MAWP. The complete range of valve settings for multiple valve installations cannot be greater than 10 percent of the highest set pressure. For high temperature water boilers, this 10 percent range may be exceeded.

ASME Section IV

This code applies to steam boilers operating at pressures not greater than 15 psig [1.03 barg] and hot water heating boilers operating at pressures not greater than 160 psig [11.03 barg] and/or temperatures not exceeding 250°F [121°C].

Steam Boilers

Valve capacity must be selected to prevent the boiler pressure from rising more than 5 psig [0.35 barg] above the MAWP.

Hot Water Boilers

Safety valve must be set to relieve at a pressure not greater than the MAWP of the boiler. If more than one safety valve is used, the secondary valve(s) may be set up to 6 psig [0.41 barg] above the MAWP for boilers with MAWPs up to and including 60 psig [4.13 barg], and 5 percent for boilers with MAWPs greater than 60 psig [4.13 barg]. Capacity must be selected to prevent the pressure from rising more than 10 percent above the set pressure of the highest set valve if more than one valve is used.

Tanks/Heat Exchangers High Temperature Water-to-Water Heat Exchangers

Valve(s) must be set at a pressure not greater than the MAWP and with sufficient capacity to prevent the pressure from increasing more than 10 percent above the MAWP.

Steam to Hot Water Supply

Valve(s) must be a least 1" [25 mm] diameter with set pressure not greater than MAWP of the tank.

High Temperature Water to Steam Heat Exchanger

Valve(s) must be set at a pressure not greater than 15 psig [1.03 barg] and with sufficient capacity to prevent the pressure from rising more than 5 psig [0.35 barg] above the MAWP.

ASME Section VIII

This code applies to unfired pressure vessels with an inside diameter larger than 6" [130 mm] and designed for use at or above 15 psig [1.03 barg]. Valve(s) must prevent the pressure from rising more than 10 percent or 3 psig [0.21 barg], whichever is greater, above the MAWP. For a single valve installation, the set pressure may not be greater than the MAWP. For multiple valve installations, the first valve cannot be set higher than the MAWP, but the other valves can be set up to 5 percent above the MAWP. The pressure rise for multiple valve installations can be 16 percent or 4 psig [0.27 barg], whichever is greater. When the vessel is exposed to an external heat source, such as fire, the pressure rise can be 21 percent above the MAWP.

Notes:

1. MAWP - Maximum allowable working pressure.
2. Information stated above is based on latest code at time of publication.

ASME Codes – Requirements

National Board

Kunkle valves are manufactured at facilities that meet the manufacturing requirements of the ASME Sections I, IV, and VIII codes for pressure relief valves. Valves that have the relief capacity certified by the National Board of Boiler and Pressure Vessel Inspectors bear the following code symbol stamp on the nameplate and the letters NB. Most Kunkle Valves have NB certified capacities.

Code Stamps

“V”  - applies to all ASME Section I valves

“HV”  - applies to all ASME Section IV valves

“UV”  - applies to all ASME Section VIII valves

Notes:

- Information stated above is based on latest code at time of publication.
- Non-code liquid valves are capacity rated at 25 percent overpressure.
- Non-code air/gas/vapor and steam valves are capacity rated at 10 percent overpressure.

Power Boiler - Section I - Code “V”

Set Pressure psig	[barg]	Set Pressure Tolerance	Blowdown
15 – 66	[1.03 – 4.55]		2 – 4 psig [0.14 – 0.28 barg]
67 – 100	[4.62 – 6.90]		2 psi [0.14 barg] - 6%
101 - 250	[6.96 - 17.24]		2% - 6%
251 – 374	[17.31 – 25.79]		2% - 15 psig [1.03 barg]
375 – 1000	[25.86 – 68.96]		2% - 4%
15 – 69	[1.03 – 4.75]	±2 psig [±0.14 barg]	
70 – 300	[4.83 – 20.69]	±3%	
301 – 1000	[20.95 – 68.96]	±10% psig [±0.69 barg]	
1001 and up	[69.03 and up]	±1%	

- Overpressure would be 2 psig [0.14 barg] for pressures between 15 psig [1.03 barg] and 70 psig [4.83 barg]. Pressures above 70 psig [4.83 barg] would have an overpressure of 3%.
- Maximum blowdown for “Special Use” Section I is 10%.

Heating Boiler - Section IV - Code “HV”

	Set Pressure psig	[barg]	Set Pressure Tolerance	Blowdown	Overpressure
15 psig Steam	15	[1.03]	±2 psig [±0.14 barg]	2 – 4 psig [0.14 – 0.28 barg]	5 psig [0.34 barg]
Hot Water	15 – 60	[1.03 – 4.14]	±3 psig [±0.21 barg]	N/A	10%
Hot Water	61 – 160	[4.20 – 11.0]	±5%	N/A	10%

Unfired Pressure Vessel - Section VIII - Code “UV”

	Set Pressure psig	[barg]	Set Pressure Tolerance	Blowdown Tolerance	Overpressure
	15 – 30	[1.03 – 2.07 barg]	±2 psig [±0.14 barg]	N/A	3 psig [0.21 barg]
	31 – 70	[2.14 – 4.83 barg]	±2 psig [±0.14 barg]	N/A	10%
	71 and up	[4.90 barg and up]	±3%	N/A	10%

Non-code Set Pressure Tolerance

Set Pressure, psig [barg]	Set Pressure Tolerance, psig [barg]
Below 15 psig [1.03 barg] to 10 psig [0.69 barg]	+/- 2.0 psig [±0.14 barg]
Below 10 psig [0.69 barg] to 5.0 psig [0.34 barg]	+/- 1.0 psig [±0.07 barg]
Below 5.0 psig [0.34 barg] to 0.0 psig [0.0 barg]	+/- 0.5 psig [±0.003 barg]
Below 0.0-inch Hg [0.0 mb] to 10-inch Hg [337 mb]	+/- 1.0-inch Hg [±33.7 mb]
Below 10-inch Hg [337 mb] to 20-inch Hg [674 mb]	+/- 2.0-inch Hg [±67.4 mb]
Below 20-inch Hg [674 mb]	+/- 4.0-inch Hg [±134.8 mb]

General Safety and Relief Valve Information

Kunkle Factory Standard Seat Tightness

Code Section	Service	Performance Standard
I and VIII	Steam	No visible leakage for 15 seconds at 20% below nameplate set pressure or at 5 psig [0.35 barg] below nameplate set pressure, whichever is greater.
VIII	Air/Gas	No audible leakage for 15 seconds at 20% below nameplate set pressure or at 5 psig [0.35 barg] below nameplate set pressure, whichever is greater.
IV and VIII	Liquid	No visible leakage for 30 seconds at 20% below nameplate set pressure or at 5 psig [0.35 barg] below nameplate set pressure, whichever is greater.
IV	Steam	No visible leakage for 30 seconds at 12 psig [0.83 barg].

API - 527 Seat Tightness

Model	Code Section	Service	Performance Standard
300/600 6000 900	I and VIII	Steam	API 527 - No visible leakage for 1 minute at 10% below nameplate set pressure or 5 psig [0.35 barg] below nameplate set pressure, whichever is greater.
6010 (O-ring seat) 916/917 (soft seat) 918/919 (soft seat)	VIII	Air/Gas	API 527 - Bubble-tight for 1 minute at 10% below nameplate set pressure or 5 psig [0.35 barg] below nameplate set pressure, whichever is greater.
910/912 911/913	VIII	Air/Gas	API 527 - D and E orifice: 40 bubbles/min, F thru J orifice: 20 bubbles/min at 10% below nameplate set pressure or 5 psig [0.35 barg] below nameplate set pressure, whichever is greater.
916/917 (soft seat) 918/919 (soft seat)	VIII	Liquid	API 527 - No leakage for 1 minute at 10% below nameplate set pressure, or 5 psig [0.35 barg] below nameplate set pressure, whichever is greater.
910/912 911/913	VIII	Liquid	API 527 - 10 cc/h for inlet sizes less than 1" or 10 cc/h/in of inlet valve size for inlet sizes 1" and larger at 10% below nameplate set pressure or 5 psig [0.35 barg] below nameplate set pressure, whichever is greater.

Note:

API 527 is not available on air service for:

- a. Plain lever "J" orifice Models 900 and 6000.
- b. Plain lever Model 900 above 444 psig [30.6 barg] set pressure.

The terms "safety valve" and "relief valve" are frequently used interchangeably. This is satisfactory to the extent that both safety and relief valves of the spring-loaded type are similar in external appearance and both serve the broad general purpose of limiting media (liquid or gaseous) pressures by discharging some of the pressurized liquid or gas. Some authorities restrict "safety valves" to those installed on boilers, superheaters, and fired vessels - all others being classified as relief valves. We prefer, however, to define them briefly as follows:

Safety valves are used on gaseous service (which include air and steam). Their design always includes a huddling chamber which utilizes the expansion forces of these gases to effect quick opening (popping) and closing actions. The difference between the opening and closing pressures is termed "blowdown," and for Section I and IV steam safety valves blowdown limitations are carefully stated in the ASME Power Boiler Code. Relief valves are normally used for liquid service, although safety valves may be so used. Ordinarily, relief valves do not have an accentuated huddling chamber nor a regulator ring for varying or adjusting blowdown. They therefore operate with a semi-modulating action in proportion to the system pressure. Such relieving action is desirable to protect piping systems from water hammer.

Safety and Relief Valve Pointers

1. ASME Codes require that steam and air safety valves have test levers, although levers may be omitted on valves used in hazardous or toxic gas service.
2. Steam safety valves may be used for air service but not vice versa. Liquid valves should be used on liquid only.
3. Safety/relief valves should be installed vertically with the drain holes open or piped to a convenient location.
4. The inlet to and outlet from a safety/relief valve must be at least as large as the valve connections.
5. Every safety/relief valve is individually tested and set by Kunkle.
6. In the event you have safety/relief valve problems, first check the accuracy and cleanliness of pressure gauges and then refer to "Recommended Installation" for help in determining the cause of your problem. Feel free to consult your sales representative.
7. When ordering, we need to know size, type of connections, model number, pressure setting, required relieving capacity, and service media, or advise your complete requirements so that we can make a selection for you.
8. Following are procedures on the operation and testing of safety/ relief valves:
 - A. Avoid excessive operation of the safety/relief valve as even one opening can provide a means for leakage. Safety/relief valves should be operated only often enough to assure that they are in good working order.
 - B. Test the valve by raising the operating pressure to the set pressure of the safety/relief valve, allowing it to open and reset as it would in normal service.
 - C. Do not hand operate the valve with less than 75 percent of the stamped set pressure exerted on the underside of the disc. When hand operating, be sure to hold the valve in an open position long enough to purge accumulated foreign material from the seat area and then allow the valve to snap shut.

Safety and Relief Valve Principles of Operation

Kunkle direct spring operated pressure relief valves consist of a nozzle threaded into a cast body housing which is flanged to a pressurized system. A disc is held against the nozzle by a spring, which is contained in a bonnet. The spring is adjusted by a compression screw to permit the calibration of opening or set pressure. An adjustable nozzle ring, threaded onto the nozzle,

pressure in the system returns to a safe level, the valve closes.

Just prior to reaching set point, the pressure relief valve leaks system fluid into the huddling chamber. The fluid now acts on a larger area of the disc inside the huddling chamber (PAh), causing the valve to experience an instantaneous increase in the opening force. Refer to the Figure on page 7 to see relationship between Nozzle Area (A) and the Huddling Chamber Area (Ah). System pressure acting on the larger area will suddenly open the pressure relief valve at a rapid rate.

Although the opening is rapid and dramatic, the valve does not open fully at set point. The system pressure must increase above the set point to open the valve to its full lift and full capacity position. Maximum lift and certified flow rates will be achieved within the allowable limits (overpressure) established by various codes and standards. All pressure relief valves are allowed an overpressure allowance to reach full rated flow.

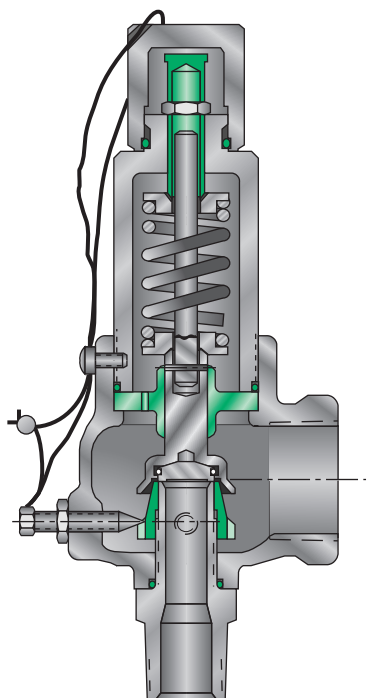

controls the geometry of the fluid exit control chamber (huddling chamber). The huddling chamber geometry is very important in controlling valve opening and closing pressures, and stability of operation. The nozzle ring is locked into position by a ring pin assembly. A cap attached to the top of the bonnet seals the internal calibration adjustments. Refer to the illustration above for the location of these important components.

Under normal system operation the valve remains in the closed position because the spring force (Fs) is greater than the system pressure acting on the internal nozzle seating area (PA). If system pressure increases to a point when these forces are equal, the valve begins to simmer. The disc lifts and fluid flows through the valve. When

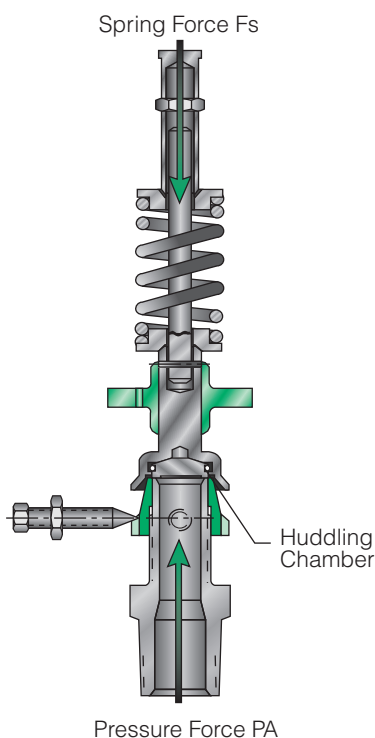

Safety and Relief Valve Principles of Operation

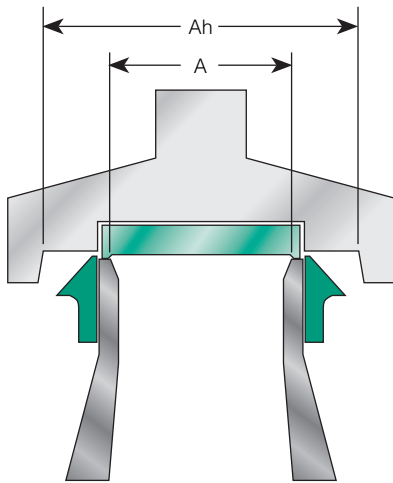

Relationship of Nozzle
Area to Huddling
Chamber Area

Once the valve has controlled the pressure excursion, system pressure will start to reduce. Since the huddling chamber area is now controlling the exit fluid flow, system pressure must reduce below the set point before the spring force is able to close the valve. The difference between the set pressure and the closing pressure is called blowdown, and is usually expressed as a percentage of set pressure. Refer to code for appropriate blowdown.

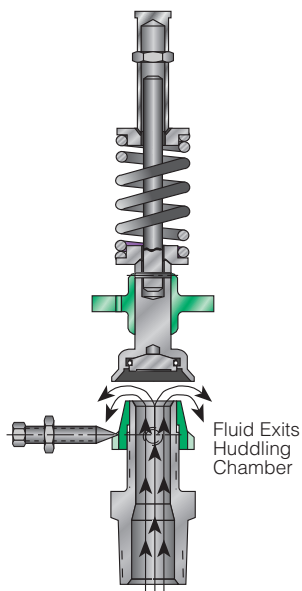

Valve Opens, Force P_{Ah} Acting on Disc

The nozzle ring adjustment changes the shape and volume of the huddling chamber, and its position will affect both the opening and closing characteristics of the valve. When the nozzle ring is adjusted to its top position, the huddling chamber is restricted to its maximum. This ring position will usually make the valve pop very distinctly with a minimum simmer (leakage before opening), but the blowdown will increase. When the nozzle ring is lowered to its lowest position, minimal restriction to the huddling chamber occurs. At this position, simmer increases and the blowdown decreases. The final ring position is somewhere between these two extremes to provide acceptable performance.

Liquid Service Operation

On liquid service, a different dynamic situation exists. Liquids do not expand when flowing across orifices, and a small amount of fluid flow across the nozzle will produce a large local pressure drop at the nozzle orifice. This local pressure drop causes the spring to reclose the valve if the fluid flow is minimal. Liquids leaking into the huddling chamber can quickly drain out by gravity and prevent fluid pressure from building up on the secondary area of the huddling chamber. Liquid relief valves are thus susceptible to a phenomenon called chatter, especially at low fluid flow rates. Chatter is the rapid opening and closing of the pressure relief valve and is often destructive in nature.

Since no visible or audible pop is heard at set point, liquid set pressure is defined as the pressure when the first heavy flow occurs (first steady vertical flow).

Ordering Information

Purchase orders must show the Size, Model Number, Set Pressure, and Service. (Include flange rating with size when applicable.)

1. To make a proper catalog selection, the following information will be needed:
 - A. Connection sizes (in and out), and types (male, female, flanged; 125#, 150#, 250#, 300#, etc.)
 - B. Material of construction
 - a. Bronze
 - b. Iron
 - c. Steel
 - d. Stainless Steel or other
 - C. Pressure setting
 - D. Service (steam, air, gas, etc., including any applicable codes or standards)
 - E. Capacity required, if available
 - F. Unusual conditions (temperature, location, etc.)

Be sure to use the capacity correction factors for superheated steam, liquid overpressure (10 percent), air-gas temperature and density correction.
 - G. If valve is to be "equal to" another brand, provide nameplate information or specification data from brand being replaced.
2. Ordering data for replacement valves may be obtained from the valve nameplate or stamping.

Valve Selection

The most critical consideration when selecting a pressure relief valve is that the valve will be capable of passing the maximum expected flow capacity. To properly select a relief valve the user must first determine the following:

1. The set pressure at which the valve is to operate. This pressure is based on the pressure limits of the system and the applicable codes. The set pressure of the primary pressure relief valve must not exceed the maximum allowable pressure of the system, but should be at least 10 percent above the maximum operating pressure.
2. The physical properties of the fluid media to be relieved. Capacity values are given in the Kunkle catalogs based on air, saturated steam, and water. Kunkle valves will relieve many other fluids, but information such as molecular weight, specific gravity, viscosity, ratio of specific heats, compressibility factor, and process temperature may be necessary to insure accurate valve selection.
3. The required relieving capacity. The ASME Boiler and Pressure Vessel Code, American Petroleum Institute Recommended Practices, and other applicable standards have many rules for obtaining the required relieving capacity and should be referenced when making this determination. The user must consider all sources of pressure generation in the system that will be protected by the pressure relief valve. Examples of pressure generation sources are pumps, heat input that may cause the system fluid to boil or expand, etc. The pressure relief valve(s) selected must exceed the worst case source of flow generation to prevent the system pressure from exceeding acceptable limits.

Once the previous information has been collected, the pressure relief valve may be sized by using the capacity charts (included in each model's catalog sheet) or by performing sizing calculations (see Valve Sizing, pages 14-25). The user will also want to consider other important factors such as:

- Connection size and type. This information is given in the Valve Selection Guide and in each of the Model Catalog sheets. Please note that the inlet to and outlet from a pressure relief valve must be at least as large as the valve connections to prevent valve malfunction.
- Pipe Size. Connection pipe sizes should not be determined by equipment connections, but rather by the relieving capacity of the PRV.
- Applicable code compliance. The ASME Code Summary section gives important information about pressure relief valves from the code. Pressure relief valve users are strongly encouraged to reference the full version of the code for important rules that may not be included in this manual.
- Maximum allowable seat leakage. The General Safety and Relief Valve Information (page 6) section of this manual shows the leakage acceptance criteria applied to each Kunkle valve. Pressure relief valve users should keep in mind that if "zero leakage" is a requirement, a soft seated valve must be selected.

- Environmental conditions. Environmental conditions play a significant role in how pressure relief valves operate. Extremely high ambient temperatures may affect the set pressure of the valve, extremely low temperatures combined with moisture can cause valves to "freeze up" and prevent proper operation, and vibration may severely shorten the service life of the valve. The Valve Selection Guide (pages 11-13) in this manual has general information on the pressure and temperature limits for each valve series. For specific model limitations refer to the individual model catalog. For vibration service, please contact your local Kunkle representative for assistance.
- Valve options. Each Kunkle model is offered with useful options such as pressure tight caps, lift lever options, or vibration dampening preparation. When selecting valve options, keep in mind that there are code requirements that may dictate what options may be used. For instance the ASME code dictates that all air, steam and hot water (140°F+[60°C]) pressure relief valves must be equipped with a lift lever. Refer to the individual model catalogs for listings of available options.
- Installation space. The individual model catalogs show envelope dimensions for each configuration and size.

For assistance on valve sizing and selection, please contact your local sales representative.

Valve Selection Guide

(For specific minimum/maximum temperature/pressure ranges refer to individual product sections.)

Steam (ASME Section I - Power Boilers)										
Model(s)	Material Connections				Inlet Size Range		Min/Max ¹ Press.		Min/Max Temp.	
	Body	Trim	NPT	FLGD	in	[mm]	psig	[barg]	°F	[°C]
300, 600	CS	SS		X	1 1/4 - 6"	[31.75 - 152.4]	15/1000	[1.0/69]	-20/800	[-29/427]
920, 921, 927 (special use – 10% blowdown)	CS	SS	X		1/2 - 2"	[12.7 - 50.8]	15/1400	[1.0/96.5]	-20/800	[-29/427]
6010, 6021, 6121, 6182 6186, 6221, 6283	Bronze	Brass	X		1/2 - 2 1/2"	[12.7 - 63.5]	3/250	[0.69/17.2]	-60/406	[-51/208]
6030, 6130, 6230	Bronze	SS	X		1/2 - 2 1/2"	[12.7 - 63.5]	3/300	[0.69/20.7]	-60/425	[-51/219]
6252	Iron	SS	X	X	1 1/2 - 6"	[38.1 - 152.4]	10/250	[0.69/17.2]	-20/406	[-29/208]

Steam (ASME Section VIII - Unfired Steam Equipment)										
1 and 2	Bronze	Brass	X		1/2 - 1"	[12.7 - 25.4]	5/250	[0.34/17.2]	-60/406	[-51/208]
264, 265	CS	SS	X		1/2 - 1"	[12.7 - 25.4]	4/3300	[0.28/227.6]	-20/750	[-29/399]
266, 267	SS	SS	X		1/2 - 1"	[12.7 - 25.4]	4/3300	[0.28/227.6]	-20/750	[-29/399]
300, 600	CS	SS		X	1 1/4 - 6"	[31.75 - 152.4]	15/1000	[1.0/69]	-20/750	[-29/399]
910	CS	SS	X	O	1/2 - 2"	[12.7 - 50.8]	3/1400	[0.21/96.5]	-20/800	[-29/427]
911	SS	SS	X	O	1/2 - 2"	[12.7 - 50.8]	3/1400	[0.21/96.5]	-320/800	[-195/427]
912	Bronze	Brass	X		1/2 - 2"	[12.7 - 50.8]	3/250	[0.21/17.2]	-320/406	[-195/208]
913	Bronze	SS	X		1/2 - 2"	[12.7 - 50.8]	3/300	[0.21/20.7]	-320/425	[-195/219]
6010, 6021, 6121, 6182, 6186, 6221, 6283	Bronze	Brass	X		1/2 - 2 1/2"	[12.7 - 63.5]	3/250	[0.21/17.2]	-60/406	[-51/208]
6030, 6130, 6230	Bronze	SS	X		1/2 - 2 1/2"	[12.7 - 63.5]	3/300	[0.21/20.7]	-60/425	[-51/219]
6252	Iron	SS	X	X	1 1/2 - 6"	[38.1 - 152.4]	10/250	[0.69/17.2]	-20/406	[-29/208]

Steam (ASME Section IV - Low Pressure Steam Heating Boilers)										
930	Iron	Bronze	X		2 - 3"	[50.8 - 76.2]	15 only	[1.0]	250 only	[122]
6933, 6934	Bronze	Brass	X		1/2 - 2"	[12.7 - 50.8]	15 only	[1.0]	250 only	[122]
6935	Bronze	SS	X		1/2 - 2"	[12.7 - 50.8]	15 only	[1.0]	250 only	[122]
6254	Iron	SS	X	X	1 1/2 - 6"	[38.1 - 152.4]	15 only	[1.0]	250 only	[122]

Steam (Non-code)²										
40R, 40RL	SS	SS	X		1/2 - 3/4"	[12.7 - 19.05]	1/400	[0.07/27.6]	-60/850	[-51/454]

X = Standard O = Optional

Notes:

1. Set pressures less than 15 psig [1.0 barg] are non-code only.
2. See also ASME Section VIII steam valves for non-code steam applications.

Valve Selection Guide

(For specific minimum/maximum temperature/pressure ranges refer to individual product sections.)

Air/Gas (ASME Section VIII)										
Model(s)	Material		Connections		Inlet Size Range		Min/Max ³ Press.		Min/Max ⁴ Temp.	
	Body	Trim	NPT	FLGD	in	[mm]	psig	[barg]	°F	[°C]
1 and 2	Brass	Brass	X		1/2 - 1"	[12.7 - 25.4]	5/250	[0.34/17.2]	-60/406	[-51/208]
30	Brass	Brass	X		1/4"	[6.35]	60/4000	[4.1/275.8]	20/300	[-6.6/150]
189	Bronze	SS	X		1/2 - 3/4"	[12.7 - 19.05]	1000/2500	[69/344.8]	-320/350	[-195/177]
264, 265	CS	SS	X		1/2 - 1"	[12.7 - 25.4]	4/3300	[0.28/227.6]	-20/750	[-29/399]
266, 267	SS	SS	X		1/2 - 1"	[12.7 - 25.4]	4/3300	[0.28/227.6]	-20/750	[-29/399]
300, 600	CS	SS		X	1 1/4 - 6"	[31.75 - 152.4]	15/1000	[1.0/69]	-20/800	[-195/427]
330 ⁵	Aluminum	SS	X		1/4"	[6.35]	1000/5500	[69/379.3]	-20/185	[-29/85]
330S, 333S ⁵	Aluminum	SS			1/4"	[6.35]	2000/6500	[138/448.3]	-20/185	[-29/85]
337	Iron	Bronze	X		2 - 3"	[50.8 - 76.2]	1/60	[0.07/4.14]	-20/406	[-29/208]
338	Aluminum	Brass	X		2"	[50.8]	5/30	[0.3/2.07]	-30/400	[-34/204]
363	Bronze	SS	X		1/2 - 3/4"	[12.7 - 19.05]	50/1000	[3.4/69]	-320/350	[-195/177]
389	SS	SS	X		1/2 - 3/4"	[12.7 - 19.05]	50/2500	[3.4/172.4]	-320/350	[-195/177]
541 (Buna disc), 542 (Viton® disc), 548 (SS disc)	Brass	Brass	X		1/4 - 1/2"	[6.35 - 12.7]	3/400	[0.21/27.6]	-20/400	[-29/204]
910, 916 (soft seat) ⁴	CS	SS	X	O	1/2 - 2"	[12.7 - 50.8]	3/1400	[0.21/96.5]	-20/800	[-29/427]
911, 917 (soft seat) ⁴	SS	SS	X	O	1/2 - 2"	[12.7 - 50.8]	3/1400	[0.21/96.5]	-320/800	[-195/427]
912, 918 (soft seat) ⁴	Bronze	Brass	X		1/2 - 2"	[12.7 - 50.8]	3/300	[0.21/20.7]	-320/406	[-195/208]
913, 919 (soft seat) ⁴	Bronze	SS	X		1/2 - 2"	[12.7 - 50.8]	3/1400	[0.21/96.5]	-320/425	[-195/219]
6010, 6121, 6182 6186, 6221, 6283 ¹	Bronze	Brass	X		1/2 - 2 1/2"	[12.7 - 63.5]	3/250	[0.21/17.2]	-60/406	[-51/208]
6030, 6130, 6320	Bronze	SS	X		1/2 - 2 1/2"	[12.7 - 63.5]	3/300	[0.21/20.7]	-60/425	[-51/219]
6252	Iron	SS	X	X	1 1/2 - 6"	[38.1 - 152.4]	10/250	[0.69/17.2]	-20/406	[-29/208]

Air/Gas ² (Non-code)										
230 (Kynar® seat)	Aluminum	SS	X		1/4"	[6.35]	300/1500	[20.7/103.4]	-20/185	[-29/85]
803 (Kynar® seat)	Aluminum	SS	X		1/4"	[6.35]	1000/6000	[69/413.8]	-20/185	[-29/85]
818 (Teflon® seat)	CS	SS/Brass	X		2"	[50.8]	120/150	[8.3/10.3]	-20/300	[-29/150]

Air/Gas (Vacuum) in Hg [mm Hg]										
215V	Iron	Bronze	X		2 - 3"	[50.8 - 76.2]	2/29	[50/736]	-20/406	[-29/208]
910, 916 (soft seat) ⁴	CS	SS	X	O	1/2 - 2"	[12.7 - 50.8]	6/29	[152/736]	-20/800	[-29/427]
911, 917 (soft seat) ⁴	SS	SS	X	O	1/2 - 2"	[12.7 - 50.8]	6/29	[152/736]	-320/800	[-195/427]
912, 918 (soft seat) ⁴	Bronze	Brass	X		1/2 - 2"	[12.7 - 50.8]	6/29	[152/736]	-320/406	[-195/208]
913, 919 (soft seat) ⁴	Bronze	SS	X		1/2 - 2"	[12.7 - 50.8]	6/29	[152/736]	-320/425	[-195/219]

X = Standard O = Optional

Notes:

1. Soft seat available on some models.
2. See also Section VIII air valves for non-code air/gas applications.
3. Set pressures less than 15 psig [1.0 barg] are non-code only.
4. Temperature limits of soft seats determine operating limits of valve.
5. Kynar® or Urethane Seat.

Valve Selection Guide

(For specific minimum/maximum temperature/pressure ranges refer to individual product sections.)

Liquid (ASME Section IV - Hot Water Boilers)										
Model(s)	Material		Connections		Inlet Size Range		Min/Max ¹ Press.		Min/Max ² Temp.	
	Body	Trim	NPT	FLGD	in	[mm]	psig	[barg]	°F	[°C]
537 (soft seat)	Iron/Bronze		Brass	X	3/4 - 2"	[19.05 - 50.8]	15/160	[1.0/11]	-20/250	[-29/121]

Liquid (ASME Section VIII)										
910, 916 (soft seat) ²	CS	SS	X	O	1/2 - 2"	[12.7 - 50.8]	3/1400	[0.21/96.5]	-20/800	[-29/427]
911, 917 (soft seat) ²	SS	SS	X	O	1/2 - 2"	[12.7 - 50.8]	3/1400	[0.21/96.5]	-320/800	[-195/427]
912, 918 (soft seat) ²	Bronze	Brass	X		1/2 - 2"	[12.7 - 50.8]	3/300	[0.21/20.7]	-320/406	[-195/208]
913, 919 (soft seat) ²	Bronze	SS	X		1/2 - 2"	[12.7 - 50.8]	3/1400	[0.21/96.5]	-320/425	[-195/219]

Liquid (Non-code)										
19, 20	Bronze	Bronze	X	O	1/2 - 3"	[12.7 - 76.2]	1/300	[0.07/20.7]	-60/406	[-51/208]
19M, 20M	Bronze	SS	X	O	2 1/2 - 3"	[63.5 - 76.2]	1/500	[0.07/34.5]	-60/406	[-51/208]
71S	Iron	SS	X		1/2 - 2"	[12.7 - 50.8]	1/250	[0.07/17.2]	-20/406	[-29/208]
171, 171P	CS	SS	X		1/2 - 2"	[12.7 - 50.8]	1/400	[0.07/27.6]	-20/550	[-29/288]
171S	SS	SS	X		1/2 - 2"	[12.7 - 50.8]	1/400	[0.07/27.6]	-20/550	[-29/288]
91	Iron	Bronze	X	X	1 1/2 - 6"	[38.1 - 152.4]	5/400	[0.34/27.6]	-20/406	[-29/208]
218,228	Iron	Bronze	X		3, 4, and 6"	[76.2 - 152.4]	60/200	[4.1/13.8]	-20/406	[-29/208]
140	SS	SS	X		3/8 - 1 1/2"	[9.5 - 12.7]	10/300	[0.69/20.7]	-60/406	[-51/208]
264, 265	CS	SS	X		1/2 - 1"	[12.7 - 25.4]	4/3300	[0.28/227.6]	-20/750	[-29/399]
266, 267	SS	SS	X		1/2 - 1"	[12.7 - 25.4]	4/3300	[0.28/227.6]	-20/750	[-29/399]
910, 916 (soft seat) ²	CS	SS	X	O	1/2 - 2"	[12.7 - 50.8]	3/1400	[0.21/96.5]	-20/800	[-29/427]
911, 917 (soft seat) ²	SS	SS	X	O	1/2 - 2"	[12.7 - 50.8]	3/1400	[0.21/96.5]	-320/800	[-195/427]
912, 918 (soft seat) ²	Bronze	Brass	X		1/2 - 2"	[12.7 - 50.8]	3/300	[0.21/20.7]	-320/406	[-195/208]
913, 919 (soft seat) ²	Bronze	SS	X		1/2 - 2"	[12.7 - 50.8]	3/1400	[0.21/96.5]	-320/425	[-195/219]

Liquid - Underwriters Laboratories (UL) For Oil Services										
200A	Bronze	Brass	X		3/4 - 1 1/2"	[19.05 - 38.1]	1/200	[0.07/13.8]	-60/406	[-51/208]
200H	Bronze	SS	X	O	3/4 - 2"	[19.05 - 50.8]	1/200	[0.07/13.8]	-60/406	[-51/208]

Liquid - Underwriters Laboratories (UL) and Factory Mutual Research (FM) For Fire Pump Water Relief										
218, 228	Iron	Bronze	X	X	3, 4 and 6"	[76.2 - 152.4]	60/200	[4.1/13.8]	-20/406	[-29/208]
918 (soft seat) ^{2,3}	Bronze	Brass	X		3/4 - 1"	[19.05 - 25.4]	60/250	[4.1/17.2]	-20/406	[-29/208]

Other - Drip Pan Elbow										
299	Iron	N/A	X	X	2 - 8"	[50.80 - 203.2]	N/A	N/A	-20/406	[-29/208]

X = Standard O = Optional

Notes:

1. Set pressures below 15 psig [1.0 barg] are non-code only.
2. Temperature limits of soft seats determine operating limits of valve.
3. FM Approved only.

Valve Sizing

After the required relieving capacity has been determined, the pressure relief valve may be sized by using the capacity charts that are included in each model's catalog sheet. The capacities given in those charts may be adjusted for special conditions such as fluid density and temperature by using the correction factors given in Tables B through D (pages 18-20). Valves may also be sized by performing sizing calculations per the formulas (pages 15 and 16) in this section.

Most Kunkle valves may be sized by using the "Coefficient Method" (listed below). These valves typically are high lift valves where the nozzle bore is the flow controlling orifice. This calculation method involves selecting the valve model and corresponding flow coefficient and orifice area from Table A (page 16) and then using the capacity formula (page 14) for the service in which the valve will function.

Kunkle Models 30, 541, 542, and 548 use the "Slope Method" for sizing calculations. These valves are typically low lift valves, where the annular orifice between the disc and the nozzle seat is the flow controlling orifice. These models are characterized by having a linear increase in capacity with respect to inlet pressure. The "slope" defines this direct relationship of inlet pressure to capacity. Consult your sales representative for sizing assistance.

Kunkle Models 1, 2, 19, 20, 200, 71S, 171, 171S, 91, 218, 228, and 140 use the "KA Method" for sizing calculations. This method is similar to the slope method, in that it is used for low lift valves and is empirically derived. The major difference is that the relationship between inlet pressure and capacity is not linear. These valves are characterized by having low lift that varies with inlet pressure, which makes the flow controlling orifice area indeterminate. Consult your sales representative for sizing assistance.

IV-A Coefficient Method

Follow these steps for calculating what orifice size is necessary to flow the required capacity:

1. Select the Model Family that you are interested in from the Valve Selection Guide (pages 10-13).
2. From Table A (page 17), record the Flow Coefficient (K_d) corresponding to the service in which the valve will operate.
3. Select the proper formula(s) for the service in which the valve will operate. Calculate the minimum required orifice area.
4. Select the Orifice/Size Designation from Table A (page 17) that has a Flow Area closest to, but not less than the minimum required orifice area calculated in step 3.

Valve Sizing

U.S. Units

Metric Units

Steam - Sections I, IV and VIII (15 psig and above)

$$A = \frac{W}{51.5 K_d P_1 K_{sh}}$$

$$A = \frac{W}{52.5 K_d P_1 K_{sh}}$$

Steam - Non Code (less than 15 psig)

$$A = \frac{W}{735 F_2 K_d} \sqrt{\frac{TZ}{M P_1 (P_1 - P_2)}}$$

$$A = \frac{W}{558 F_2 K_d} \sqrt{\frac{TZ}{M P_1 (P_1 - P_2)}}$$

Air - Section VIII (15 psig and above)

$$A = \frac{V \sqrt{MTZ}}{6.32 C K_d P_1}$$

Volumetric Flow

$$A = \frac{V \sqrt{MTZ}}{17.02 C K_d P_1}$$

Volumetric Flow

$$A = \frac{W}{C K_d P_1} \sqrt{\frac{TZ}{M}}$$

Mass Flow

$$A = \frac{1.316W}{C K_d P_1} \sqrt{\frac{TZ}{M}}$$

Mass Flow

Air - Non-Code (less than 15 psig)

$$A = \frac{V}{4645.2 F_2 K_d} \sqrt{\frac{MTZ}{P_1 (P_1 - P_2)}}$$

$$A = \frac{V}{12503 F_2 K_d} \sqrt{\frac{MTZ}{P_1 (P_1 - P_2)}}$$

Liquid - Section VIII (15 psig and above)

$$A = \frac{Q}{38 K_d} \sqrt{\frac{G}{(1.1 p_1 - p_2)}}$$

$$A = \frac{Q}{5.094 K_d} \sqrt{\frac{G}{(1.1 p_1 - p_2)}}$$

Liquid - Non-Code

$$A = \frac{Q}{38 K_d} \sqrt{\frac{G}{(1.25 p_1 - p_2)}}$$

$$A = \frac{Q}{5.094 K_d} \sqrt{\frac{G}{(1.25 p_1 - p_2)}}$$

F₂ - Coefficient of Subcritical Flow

$$F_2 = \sqrt{\left(\frac{k}{k-1}\right) \left(r\right)^{2/k} \left[\frac{1-r^{(k-1)/k}}{1-r}\right]}$$

Note:

1. Consult your sales representative for sizing assistance for product groups: Fig. 1 and 2; Fig. 19, 20, 200; Fig. 30; Fig. 71S, 171, 171S; Fig. 91, 218, 228; Fig. 140; and Fig. 541, 542 and 548.

Valve Sizing

Sizing Coefficient Method

- A = Required effective discharge area of the valve, in² [cm²]
 W = Mass Flow Rate, lb/hr [kg/hr]
 V = Volumetric Flow Rate (gases, vapors) in SCFM [Nm³/hr] at standard atmospheric conditions of 14.7 psia and 60°F [1.013 bara/0°C]
 Q = Volumetric Flow Rate (liquids) in GPM [m³/hr] at standard atmospheric conditions of 14.7 psia and 70°F [1.013 bara/21°C]
 K_d = ASME Flow Coefficient of Discharge
 P₁ = See chart below
 P₂ = Atmospheric Pressure = 14.7 psia
 p₁ = Set Pressure (psig)
 p₂ = Back Pressure (psig)
 F₂ = Coefficient of Subcritical Flow
 k = Ratio of Specific Heat - 1.31 for Steam, 1.4 for Air
 r = Ratio of Back Pressure to Upstream Relieving Pressure = P₂/P₁
 M = Molecular Weight of Process Medium
 T = Relieving Temperature, °R = °F + 460 [°K = °C + 273]
 Z = Compressibility Factor (assume Z = 1 if unknown)
 C = Gas Constant based on k (if unknown, use C = 315)
 G = Specific Gravity of process fluid at 70°F [21°C]
 K_{sh} = Superheat Steam Correction Factor

Allowable Overpressure

Designation	Section	Definition
P ₁	Section I Steam (15 psig and above)	Set pressure + 3% or 2 psi overpressure (whichever is greater) + 14.7 psia
P ₁	Section IV Steam (15 psig and above)	Set pressure + 5 psi overpressure + 14.7 psia for Low Pressure Steam Boilers
P ₁	Section IV Hot Water (15 psig and above)	Set pressure + 10% overpressure + 14.7 psia for Hot Water Boilers
P ₁	Non-Code Steam (below 15 psig)	Set pressure + 10% overpressure + 14.7 psia
P ₁	Section VIII Steam (15 psig and above)	Set pressure + 10% or 3 psi overpressure (whichever is greater) + 14.7 psia
P ₁	Non-Code Air (below 15 psig)	Set pressure + 10% overpressure + 14.7 psia
P ₁	Section VIII Air (15 psig and above)	Set pressure + 10% or 3 psi overpressure (whichever is greater) + 14.7 psia
P ₁	Non-Code Liquid (below 15 psig)	Set pressure (psig)
P ₁	Section VIII Liquid (15 psig and above)	Set pressure (psig)

Valve Sizing

Table A						
Model Family	Orifice/Size Designation	Flow Area in ² [cm ²]		Flow Coefficient (K _d)		
				Non-Code and ASME Section VIII Air/Gas and Steam	ASME Section I Steam	ASME Section IV Steam
189	C	0.034	[0.219]	0.874		
	D	0.034	[0.219]	0.874		
264	C	0.110	[0.710]	0.766		0.408
	D	0.110	[0.710]	0.766		0.408
	E	0.110	[0.710]	0.766		0.408
337	H	1.838	[11.858]	0.860		
	J	2.786	[17.974]	0.860		
	K	4.037	[26.045]	0.860		
537	D	0.533	[3.439]			0.806
	E	0.833	[5.374]			0.806
	G	1.767	[11.400]			0.806
	H	3.142	[20.271]			0.806
910	D	0.121	[0.781]	0.878	0.878	0.710
	E	0.216	[1.394]	0.878	0.878	0.710
	F	0.337	[2.174]	0.878	0.878	0.710
	G	0.553	[3.568]	0.878	0.878	0.710
	H	0.864	[5.574]	0.878	0.878	0.710
	J	1.415	[9.129]	0.878	0.878	0.710
930	H	5.080	[32.774]			0.818
	J	6.350	[40.968]			0.818
	K	7.620	[49.161]			0.818
6010	D	0.121	[0.781]	0.878	0.878	0.878
	E	0.216	[1.394]	0.878	0.878	0.878
	F	0.337	[2.174]	0.878	0.878	0.878
	G	0.553	[3.568]	0.878	0.878	0.878
	H	0.864	[5.574]	0.878	0.878	0.878
	J	1.415	[9.129]	0.878	0.878	0.878
6252	J	1.414	[9.123]	0.878	0.878	0.878
	K	2.022	[13.045]	0.878	0.878	0.878
	L	3.138	[20.245]	0.878	0.878	0.878
	M	3.960	[25.548]	0.878	0.878	0.878
	N	4.774	[30.800]	0.878	0.878	0.878
	P	7.018	[45.277]	0.878	0.878	0.878
	R	17.600	[113.548]	0.878	0.878	0.878

Valve Sizing

Table B - Steam Super Heat Correction Factor, K_{sh}

Set Pressure psig [barg]	Saturated Steam Temp. °F [°C]	Total Steam Temperature °F [°C]															
		280 [138]	300 [149]	320 [160]	340 [171]	360 [182]	380 [193]	400 [205]	420 [216]	440 [227]	460 [238]	480 [249]	500 [260]	520 [271]	540 [282]	560 [293]	
15 [1.03]	250 [121]	1.00	1.00	1.00	.99	.99	.98	.98	.97	.96	.95	.94	.93	.92	.91	.90	
20 [1.38]	259 [126]	1.00	1.00	1.00	.99	.99	.98	.98	.97	.96	.95	.94	.93	.92	.91	.90	
40 [2.76]	287 [142]		1.00	1.00	1.00	.99	.99	.98	.97	.96	.95	.94	.93	.92	.91	.90	
60 [4.14]	308 [153]			1.00	1.00	.99	.99	.98	.97	.96	.95	.94	.93	.92	.91	.90	
80 [5.52]	324 [162]				1.00	1.00	.99	.99	.98	.97	.96	.94	.93	.92	.91	.90	
100 [6.90]	338 [170]					1.00	1.00	.99	.98	.97	.96	.95	.94	.93	.92	.91	
120 [8.27]	350 [177]						1.00	1.00	.99	.98	.97	.96	.95	.94	.93	.92	
140 [9.65]	361 [183]							1.00	1.00	.99	.98	.96	.95	.94	.93	.92	
160 [11.0]	371 [188]								1.00	1.00	.99	.98	.97	.95	.94	.93	
180 [12.4]	380 [193]									1.00	.99	.98	.97	.96	.95	.93	
200 [13.8]	388 [198]										1.00	.99	.99	.97	.96	.95	
220 [15.2]	395 [202]									1.00	1.00	.9	.98	.96	.95	.94	
240 [16.6]	403 [206]										1.00	.99	.98	.97	.95	.94	
260 [17.9]	409 [210]											1.00	.99	.98	.97	.96	
280 [19.3]	416 [213]										1.00	1.00	.98	.97	.96	.95	
300 [20.7]	422 [217]											1.00	.99	.98	.96	.95	
350 [24.1]	436 [225]												1.00	1.00	.99	.96	
400 [27.6]	448 [231]													1.00	.99	.96	
450 [31.0]	460 [238]														1.00	.96	
500 [34.5]	470 [243]															1.00	
550 [37.9]	480 [249]															.97	
600 [41.4]	489 [254]															.97	
650 [44.8]	497 [258]															.97	
700 [48.3]	506 [263]															1.00	
750 [51.7]	513 [267]															1.00	
800 [55.2]	520 [271]															1.00	
850 [58.6]	527 [275]															1.00	
900 [62.1]	533 [278]															1.00	
950 [65.5]	540 [282]															1.00	
1000 [69.0]	546 [286]															1.00	
1050 [72.4]	552 [289]															1.00	
1100 [75.9]	558 [292]																
1150 [79.3]	563 [295]																
1200 [82.7]	569 [298]																

Note:

Revised capacity for "Super Heat Steam:" multiply capacity of Valve x Factor noted above.

Valve Sizing

Table B - Steam Super Heat Correction Factor, K_{SH}

Set Pressure psig [barg]	Saturated Steam Temp. °F [°C]	Total Steam Temperature °F [°C]															
		580 [305]	600 [316]	620 [326]	640 [338]	660 [349]	680 [360]	700 [371]	720 [382]	740 [393]	760 [405]	780 [416]	800 [427]	900 [482]	1000 [537]	1100 [593]	
15 [1.03]	250 [121]	.89	.88	.87	.86	.86	.85	.84	.83	.83	.82	.81	.81	.78	.75	.72	
20 [1.38]	259 [126]	.89	.88	.87	.86	.86	.85	.84	.83	.83	.82	.81	.81	.78	.75	.72	
40 [2.40]	287 [142]	.89	.88	.87	.87	.86	.85	.84	.84	.83	.82	.82	.81	.78	.75	.72	
60 [4.14]	308 [153]	.89	.88	.87	.87	.86	.85	.84	.84	.83	.82	.82	.81	.78	.75	.72	
80 [5.52]	324 [162]	.89	.89	.88	.87	.86	.85	.84	.84	.83	.82	.82	.81	.78	.75	.72	
100 [6.90]	338 [170]	.90	.89	.88	.87	.86	.85	.85	.84	.83	.82	.82	.81	.78	.75	.72	
120 [8.27]	350 [177]	.90	.89	.88	.87	.86	.85	.85	.84	.83	.82	.82	.81	.78	.75	.72	
140 [9.65]	361 [183]	.90	.89	.88	.87	.86	.85	.85	.84	.83	.82	.82	.81	.78	.75	.72	
160 [11.0]	371 [188]	.90	.89	.88	.87	.86	.86	.85	.84	.83	.82	.82	.81	.78	.75	.72	
180 [12.4]	380 [193]	.90	.89	.88	.87	.86	.86	.85	.84	.83	.82	.82	.81	.78	.75	.72	
200 [13.8]	388 [198]	.90	.89	.88	.87	.86	.86	.85	.84	.83	.83	.82	.81	.78	.75	.72	
220 [15.2]	395 [201]	.91	.90	.89	.88	.87	.86	.85	.84	.84	.83	.82	.81	.78	.75	.72	
240 [16.6]	403 [206]	.91	.90	.89	.88	.87	.86	.85	.84	.84	.83	.82	.81	.78	.75	.72	
260 [17.9]	409 [209]	.91	.90	.89	.88	.87	.86	.85	.85	.84	.83	.82	.81	.78	.75	.72	
280 [19.3]	416 [213]	.91	.90	.91	.88	.87	.86	.85	.85	.84	.83	.82	.82	.78	.75	.72	
300 [20.7]	422 [217]	.91	.90	.89	.88	.87	.86	.86	.85	.84	.83	.82	.82	.78	.75	.72	
350 [24.1]	436 [224]	.92	.91	.90	.89	.88	.87	.86	.85	.84	.83	.83	.82	.78	.76	.72	
400 [27.6]	448 [231]	.92	.91	.90	.89	.88	.87	.86	.85	.84	.84	.83	.82	.79	.76	.72	
450 [31.0]	460 [238]	.93	.92	.91	.89	.88	.87	.86	.86	.85	.84	.83	.82	.79	.76	.72	
500 [34.5]	470 [243]	.93	.92	.91	.90	.89	.88	.87	.86	.85	.84	.83	.82	.79	.76	.73	
550 [37.9]	480 [249]	.94	.92	.91	.90	.89	.88	.87	.86	.85	.84	.83	.82	.79	.76	.73	
600 [41.4]	489 [254]	.94	.93	.92	.90	.89	.88	.87	.86	.85	.84	.84	.83	.79	.76	.73	
650 [44.8]	497 [258]	.95	.94	.92	.91	.90	.89	.87	.86	.86	.85	.84	.83	.79	.76	.73	
700 [48.3]	506 [263]	.96	.94	.93	.91	.90	.89	.88	.87	.86	.85	.84	.83	.79	.76	.73	
750 [51.7]	513 [267]	.96	.95	.93	.92	.90	.89	.88	.87	.86	.85	.84	.83	.79	.76	.73	
800 [55.2]	520 [271]	.97	.95	.94	.92	.91	.90	.88	.87	.86	.85	.84	.84	.80	.76	.73	
850 [58.6]	527 [275]	.98	.96	.94	.93	.92	.90	.89	.88	.87	.86	.85	.84	.80	.76	.73	
900 [62.1]	533 [278]	.99	.97	.95	.93	.92	.90	.89	.88	.87	.86	.85	.84	.80	.77	.73	
950 [65.5]	540 [282]	.99	.97	.95	.94	.92	.91	.89	.88	.87	.86	.85	.84	.80	.77	.73	
1000 [69.0]	546 [286]	.99	.98	.96	.94	.93	.91	.90	.89	.87	.86	.85	.84	.80	.77	.73	
1050 [72.4]	552 [289]	1.00	.99	.97	.95	.93	.92	.90	.89	.88	.87	.86	.85	.80	.77	.73	
1100 [75.9]	558 [292]	1.00	.99	.98	.95	.94	.92	.91	.89	.88	.87	.86	.85	.81	.77	.73	
1150 [79.3]	563 [295]	1.00	.99	.98	.96	.94	.92	.91	.90	.88	.87	.86	.85	.81	.77	.73	
1200 [82.7]	569 [298]	1.00	.99	.98	.97	.95	.93	.91	.90	.89	.87	.86	.85	.81	.77	.73	

Note:

Revised capacity for "Super Heat Steam:" multiply capacity of Valve x Factor noted above.

Valve Sizing

Table C - Air and Gas Temperature Correction Factors

Temperature °F	Tc	Temperature °F	Tc	Temperature °F	Tc	Temperature °F	Tc
0	1.062	90	0.972	260	0.849	440	0.760
10	1.051	100	0.964	280	0.838	460	0.752
20	1.041	120	0.947	300	0.828	480	0.744
30	1.030	140	0.931	320	0.817	500	0.737
40	1.020	160	0.916	340	0.806	550	0.718
50	1.009	180	0.902	360	0.796	600	0.701
60	1.000	200	0.888	380	0.787	650	0.685
70	0.991	220	0.874	400	0.778	700	0.669
80	0.981	240	0.862	420	0.769	750	0.656

For temperatures other than 60°F at valve inlet, multiply standard SCFM by Tc.

Table D - Gas and Liquid Relative Density Correction Factors

Specific Gravity	Dc	Specific Gravity	Dc	Specific Gravity	Dc	Specific Gravity	Dc
0.07	3.770	0.60	1.290	1.05	0.975	1.70	0.768
0.08	3.530	0.65	1.240	1.10	0.955	1.80	0.745
0.09	3.333	0.70	1.195	1.15	0.933	1.90	0.725
0.10	3.160	0.75	1.155	1.20	0.913	2.00	0.707
0.20	2.240	0.80	1.117	1.25	0.895	2.50	0.633
0.30	1.825	0.85	1.085	1.30	0.877	3.00	0.577
0.40	1.580	0.90	1.055	1.40	0.845	3.50	0.535
0.50	1.414	0.95	1.025	1.50	0.817	4.00	0.500
0.55	1.350	1.00	1.000	1.60	0.791	4.50	0.471

For a specific gravity other than air or water (=1.0), multiply CFM or GPM by Dc.

Valve Sizing

Physical Properties

Gas or Vapor	M Molecular Weight	k Specific Heat Ratio	C Gas Constant
Acetone	58.08	1.12	329
Acetylene (Ethyne)	26.04	1.26	343
Air	28.97	1.40	356
Ammonia, Anhydrous	17.03	1.31	348
Argon	39.95	1.67	378
Benzene (Benzol or Benzole)	78.11	1.12	329
Boron Trifluoride	67.82	1.20	337
Butadiene-1,3 (Divinyl)	54.09	1.12	329
Butane-n (Normal Butane)	58.12	1.09	326
Butylene (1-Butene)	56.11	1.11	328
Carbon Dioxide	44.01	1.29	346
Carbon Disulfide (C. Bisulfide)	76.13	1.21	33
Carbon Monoxide	28.01	1.40	356
Carbon Tetrachloride	153.82	1.11	328
Chlorine	70.91	1.36	353
Chloromethane (Methyl Chloride)	50.49	1.28	345
Cyclohexane	84.16	1.09	326
Cyclopropane (Trimethylene)	42.08	1.11	328
Decane-n	142.29	1.04	320
Diethylene Glycol (DEG)	106.17	1.07	323
Dimethyl Ether (Methyl Ether)	46.07	1.11	328
Dowtherm A	165.00	1.05	321
Dowtherm E	147.00	1.00	315
Ethane	30.07	1.19	336
Ethyl Alcohol (Ethanol)	46.07	1.13	330
Ethylene (Ethene)	28.05	1.24	341
Ethylene Glycol	62.07	1.09	326
Ethylene Oxide	44.05	1.21	338
Fluorocarbons:			
12, Dichlorodifluoromethane	120.93	1.14	331
13, Chlorotrifluoromethane	104.47	1.17	334
13B1, Bromotrifluoromethane	148.93	1.14	331
22, Chlorodifluoromethane	86.48	1.18	335
115, Chloropentafluoroethane	154.48	1.08	324
Glycerine (Glycerin or Glycerol)	92.10	1.06	322
Helium	4.00	1.67	378
Heptane	100.21	1.05	321

Valve Sizing

Physical Properties

Gas or Vapor	M Molecular Weight	k Specific Heat Ratio	C Gas Constant
Hexane	86.18	1.06	322
Hydrogen	2.02	1.41	357
Hydrogen Chloride, Anhydrous	36.46	1.41	357
Hydrogen Sulfide	34.08	1.32	349
Isobutane (2-Methylpropane)	58.12	1.10	327
Isoprene (2-Methyl-1, 3 Butadiene)	68.12	1.09	326
Isopropyl Alcohol (Isopropanol)	60.10	1.09	326
Krypton	83.80	1.71	380
Methane	16.04	1.31	348
Methyl Alcohol (Methanol)	32.04	1.20	337
Methylamines, Anhydrous			
Monomethylamine (Methylamine)	31.06	1.02	317
Dimethylamine	45.08	1.15	332
Trimethylamine	59.11	1.18	335
Methyl Mercapton (Methanethiol)	48.11	1.20	337
Naphthalene (Naphthaline)	128.17	1.07	323
Natural Gas (specific gravity = 0.60)	17.40	1.27	344
Neon	20.18	1.64	375
Nitrogen	28.01	1.40	356
Nitrous Oxide	44.01	1.30	347
Octane	114.23	1.05	321
Oxygen	32.00	1.40	356
Pentane	72.15	1.07	323
Propadiene (Allene)	40.07	1.69	379
Propane	44.10	1.13	330
Propylene (Propene)	42.08	1.15	332
Propylene Oxide	58.08	1.13	330
Styrene	104.15	1.07	323
Sulfur Dioxide	64.06	1.28	345
Sulfur Hexafluoride	146.05	1.09	326
Steam	18.02	1.31	348
Toluene (Toluol or Methylbenzene)	92.14	1.09	326
Triethylene Glycol (TEG)	150.18	1.04	320
Vinyl Chloride Monomer (VCM)	62.50	1.19	336
Xenon	131.30	1.65	376
Xylene (p-Xylene)	106.17	1.07	323

Valve Sizing

Physical Properties

Liquid	G Specific Gravity Water = 1	°F	°C
Acetaldehyde	0.779	68	20
Acetic Acid	1.051	68	20
Acetone	0.792	68	20
Ammonia, Anhydrous	0.666	68	20
Automotive Crankcase and Gear Oils:			
SAE-5W Through SAE 150	0.88-0.94	60	15.6
Beer	1.01	60	15.6
Benzene (Benzol)	0.880	68	20
Boron Trifluoride	1.57	-148	-100
Butadiene - 1, 3	0.622	68	20
Butane-n (Normal Butane)	0.579	68	20
Butylene (1-Butene)	0.600	68	20
Carbon Dioxide	1.03	-4	-20
Carbon Disulfide (C. Bisulfide)	1.27	68	20
Carbon Tetrachloride	1.60	68	20
Chlorine	1.42	68	20
Chloromethane (Methyl Chloride)	0.921	68	20
Crude Oils:			
32.6 Deg API	0.862	60	15.6
35.6 Deg API	0.847	60	15.6
40 Deg API	0.825	60	15.6
48 Deg API	0.79	60	15.6
Cyclohexane	0.780	68	20
Cyclopropane (Trimethylene)	0.621	68	20
Decane-n	0.731	68	20
Diesel Fuel Oils	0.82-0.95	60	15.6
Diethylene Glycol (DEG)	1.12	68	20
Dimethyl Ether (Methyl Ether)	0.663	68	20
Dowtherm A	0.998	68	20
Dowtherm E	1.087	68	20
Ethane	0.336	68	20
Ethyl Alcohol (Ethanol)	0.79	68	20
Ethylene (Ethene)	0.569	-155	-104
Ethylene Glycol	1.115	68	20
Ethylene Oxide	0.901	68	20

Valve Sizing

Physical Properties

Liquid	G Specific Gravity Water = 1	°F	°C
Fluorocarbons:			
R12, Dichlorodifluoromethane	1.34	68	20
R13, Chlorotrifluoromethane	0.916	68	20
R13B1, Bromotrifluoromethane	1.58	68	20
R22, Chlorodifluoromethane	1.21	68	20
R115, Chloropentafluoromethane	1.31	68	20
Fuel Oils, Nos. 1, 2, 3, 5 and 6	0.82-0.95	60	15.6
Gasolines	0.68-0.74	60	15.6
Glycerine (Glycerin or Glycerol)	1.26	68	20
Heptane	0.685	68	20
Hexane	0.660	68	20
Hydrochloric Acid	1.64	60	15.6
Hydrogen Sulfide	0.78	68	20
Isobutane (2-Methylpropane)	0.558	68	20
Isoprene (2-Methyl - 1, 3-Butadiene)	0.682	68	20
Isopropyl Alcohol (Isopropanol)	0.786	68	20
Jet Fuel (average)	0.82	60	15.6
Kerosene	0.78-0.82	60	15.6
Methyl Alcohol (Methanol)	0.792	68	20
Methylamines, Anhydrous:			
Monomethylamine (Methylamine)	0.663	68	20
Dimethylamine	0.656	68	20
Trimethylamine	0.634	68	20
Methyl Mercapton (Methanethiol)	0.870	68	20
Nitric Acid	1.50	60	15.6
Nitrous Oxide	1.23	-127	-88.5
Octane	0.703	68	20
Pentane	0.627	68	20
Propadiene (Allene)	0.659	-30	-34.4
Propane	0.501	68	20
Propylene (Propene)	0.514	68	20
Propylene Oxide	0.830	68	20
Styrene	0.908	68	20
Sulfur Dioxide	1.43	68	20

Valve Sizing

Physical Properties

Liquid	G Specific Gravity Water = 1	°F	°C
Sulfur Hexafluoride	1.37	68	20
Sulfuric Acid:			
95–100%	1.839	68	20
60%	1.50	68	20
20%	1.14	68	20
Toluene (Toluol or Methylbenzene)	0.868	68	20
Triethylene Glycol (TEG)	1.126	68	20
Vinyl Chloride Monomer (VCM)	0.985	-4	-20
Water, fresh	1.00	68	20
Water, sea	1.03	68	20
Xylene (p-Xylene)	0.862	68	20

Sizing - Determining K_v and K_w

U.S. Units

$$R = \frac{V_L (2,800 G)}{\mu \sqrt{A}}$$

or

$$R = \frac{12,700 V_L}{U \sqrt{A}}$$

Metric Units

$$R = \frac{31,313 V_L G}{\mu \sqrt{A}}$$

Determining K_v

V_L = Flow rate at the flowing temperature, in U.S. gpm [m³/hr]

V_L = Flow rate at the flowing temperature, in U.S. gpm [m³/hr]

G = Specific gravity of liquid at flowing temperature referred to water = 1.00 at 70°F [21°C]

μ = Absolute viscosity at the flowing temperature, in centipoises

A = Effective discharge area, in square inches [cm²] (from manufacturer's standard orifice areas)

U = Viscosity at the flowing temperature, in Saybolt Universal seconds

After the value of R is determined, the factor K_v is obtained from the graph. Factor K_v is applied to correct the "preliminary required discharge area." If the corrected area exceeds the "chosen standard orifice area," the calculations should be repeated using the next larger standard orifice size.

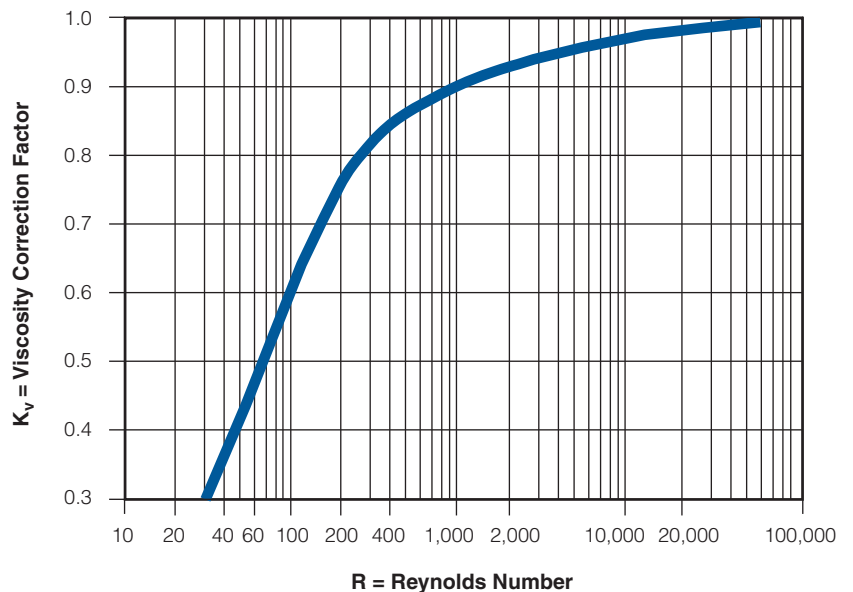

Conversion Factors

Absolute Viscosity				
Given	To find desired value, multiply "Given" value by factor below			
	poise	Centipoise	$\frac{\text{gm}}{\text{cm-sec}}$	$\frac{\text{lb}}{\text{ft-sec}}$
poise	—	100	1	0.0672
centipoise	0.01	—	0.01	0.000672
$\frac{\text{gm}}{\text{cm-sec}}$	1	100	—	0.0672
$\frac{\text{lb}}{\text{ft-sec}}$	14.88	1488	14.88	—

Notes:

1. Kinematic viscosity x specific gravity = absolute viscosity.
2. Centistokes x specific gravity = centipoise.
3. Saybolt Second Universal (SSU) x 0.216 x specific gravity = centipoise.

Kinematic Viscosity				
Given	To find desired value, multiply "Given" value by factor below			
	stoke	Centistoke	$\frac{\text{cm}^2}{\text{sec}}$	$\frac{\text{ft}^2}{\text{sec}}$
stoke	—	100	1	0.001076
centistoke	0.01	—	0.01	1.076 x 10 ⁻⁵
$\frac{\text{cm}^2}{\text{sec}}$	1	100	—	0.001076
$\frac{\text{ft}^2}{\text{sec}}$	929.0	92900	929.0	—

Liquid Flow Conversions					
Given	To find desired value, multiply "Given" value by factor below				
	l/hr	gpm - US	gpm - Imp	barrels/day	m ³ /hr
l/hr (litres/hour)	—	0.00440	0.003666	0.1510	0.0010
gpm (US gallons per minute)	227.1	—	0.8327	34.29	0.2271
gpm (Imperial gallons per minute)	272.8	1.201	—	41.18	0.2728
barrels/day (petroleum - 42 US gallons)	6.624	0.02917	0.02429	—	0.006624
m ³ /hr (cubic meters per hour)	1000	4.403	3.666	151.0	—
m ³ /s (cubic meters per second)	3.6 x 10 ⁶	0.02917	0.02429	—	0.006624
kg/hr (kilograms per hour)	$\frac{1}{\text{G}}$	$\frac{1}{227.1\text{G}}$	$\frac{1}{272.8\text{G}}$	$\frac{0.151}{\text{G}}$	$\frac{1}{1000\text{G}}$
lb/hr (pounds per hour)	$\frac{1}{2.205\text{G}}$	$\frac{1}{500.8\text{G}}$	$\frac{1}{601.5\text{G}}$	$\frac{1}{14.61\text{G}}$	$\frac{1}{2205\text{G}}$

Note:

1. G = Specific gravity of liquid at its relieving temperature compared to that of water at 68°F [20°C], where G_{water} = 1.00.

Conversion Factors

Gas Flow Conversions						
Given	To find desired value, multiply "Given" value by factor below					
	SCFM	SCFH	lb/hr	[kg/hr]	[Nm ³ /hr]	[Nm ³ /min]
scfm ²	—	60	$\frac{M}{6.32}$	$\frac{M}{13.93}$	1.608	0.0268
scfh ²	0.01677	—	$\frac{M}{379.2}$	$\frac{M}{836.1}$	0.0268	0.000447
lb/hr ³ or #/hr ³	$\frac{6.32}{M}$	$\frac{379.2}{M}$	—	0.4536	$\frac{10.17}{M}$	$\frac{0.1695}{M}$
kg/hr ⁴	$\frac{13.93}{M}$	$\frac{836.1}{M}$	2.205	—	$\frac{22.40}{M}$	$\frac{0.3733}{M}$
Nm ³ /hr ⁵	0.6216	37.30	$\frac{M}{10.17}$	$\frac{M}{22.40}$	—	0.01667
Nm ³ /min ⁵	37.30	2238	5.901 M	2.676 M	60	—

If flow is expressed in actual volume, such as cfm (cubic feet per minute) or acfm (actual cfm) as is often done for compressors, where the flow is described as

displacement or swept volume, the flow may be converted to scfm as follows (or from flow expressed in m³/hr to Nm³/hr).

Inch-Pound Units

$$\text{SCFM} = \left(\frac{\text{cfm}}{\text{acfm}} \right) \times \frac{14.7 + p}{14.7} \times \frac{520}{460 + t}$$

Where:

p = gauge pressure of gas or vapor in psig
t = temperature of gas or vapor in °F

Metric Units

$$\text{Nm}^3/\text{hr} = \text{m}^3/\text{hr} = x \frac{1.013 + p}{1.013} \times \frac{273}{273 + t}$$

Where:

p = gauge pressure of gas or vapor in barg
t = temperature of gas or vapor in °C

Notes:

1. M = Molecular weight of vapor or gas.
2. Volumetric flow (per time unit of hour or minute as shown) in standard cubic feet per minute at 14.7 psia [1.013 bara], 60°F [16°C].
3. Weight flow in pounds per hour.
4. Weight flow in kilograms per hour.
5. Volumetric flow (per time unit of hour or minute as shown) at 1.013 bara 32°F [0°C]. This represents the commercial standard, known as the Normal Temperature and Pressure (NTP).

Conversions from one volumetric flow rate to another or to weight flow (and vice versa) may only be done when the volumetric flow is expressed in the standard conditions shown above. If flows are expressed at temperature or pressure bases that differ from those listed above, they must first be converted to the standard base.

Pressure Conversion				
Given	To find desired value, multiply "Given" value by factor below			
	kPa	psig	kg/cm ²	barg
kPa (kilopascal)	—	0.1450	0.0102	0.0100
psig (pounds/in ²) ³	6.895	—	0.0703	0.06895
kg/cm ² (1)(kilograms/cm ²)	98.07	14.22	—	0.9807
barg	100.00	14.50	1.020	—

Area Conversion				
Given	To find desired value, multiply "Given" value by factor below			
	in ²	ft ²	mm ²	cm ²
in ²	—	0.006944	645.16	6.4516
cm ²	0.155	1.076 x 10 ⁻³	100	—
ft ²	144	—	92900	929
mm ²	0.00155	1.076 x 10 ⁻⁵	—	0.01

Temperature Conversion	
Degrees Celsius (°C)	Degrees Fahrenheit (°F)
C + 273.15 = K (Kelvin)	F + 459.67 = R (Rankine)
(C x 1.8) + 32 = F (Fahrenheit)	(F - 32) x 0.556 = C (Celsius)

Notes:

1. Also expressed as kp/cm² and kgf/cm².
2. Normal Temperature and Pressure (NTP) Conditions are, at sea level, equal to 1.013 bara or 1.033 kg/cm² (kilograms force per square centimeter absolute) at a base temperature of 32°F [0°C]. This differs slightly from Metric Standard Conditions (MSC), which uses 1.013 bara 60°F [15°C] for the base temperature.
3. Inch-Pound Standard Conditions are, at sea level, equal to 14.7 psia (pounds force per square inch absolute), rounded up from 14.696 psia, and at a base temperature of 60°F [16°C].

Installation

1. Before installing a new safety/relief valve, we recommend that a pipe tap be used to assure clean-cut and uniform threads in the vessel opening and to allow for normal hand engagement followed by a half to one turn by wrench.
2. Install the valve in a vertical position so that discharge piping and code required drains can be properly piped to prevent build-up of back pressure and accumulation of foreign material around the valve seat area.
3. Avoid over-tightening as this can distort safety/relief valve seats. One need only remember that as the vessel and valve are heated, the expansion involved will grasp the valve more firmly.
4. When installing flange connected valves, use new gaskets and draw the mounting bolts down evenly.
5. Do not use the valve outlet or cap as a lever for installation. Use only flat jawed wrenches on the flats provided.
6. Avoid excessive "popping" of the safety/relief valve as even one opening can provide a means for leakage. Safety/relief valves should be operated only often enough to assure that they are in good working order.
7. Avoid wire, cable, or chain pulls for attachment to levers that do not allow a vertical pull. The weight of these devices should not be directed to the safety/relief valve.
8. Avoid having the operating pressure too near the safety/relief valve set pressure. A very minimum differential of 5 psig or 10 percent (whichever is greater) is recommended. An even greater differential is desirable, when possible, to assure better seat tightness and valve longevity. Safety/relief valves in high-temperature hot water and organic fluid service are more susceptible to damage and leakage than safety valves for steam. It is recommended that the maximum allowable working pressure of the boiler and the safety/relief valve setting be selected substantially higher than the operating pressure. A differential of 30-40 percent is recommended.
9. Avoid discharge piping where its weight is carried by the safety/relief valve. Even though supported separately, changes in temperature alone can cause piping strain. We recommend that drip pan elbows or flexible connections be used wherever possible (see Type A, B, C Installation, page 29).
10. Apply a moderate amount of pipe compound to male threads only, leaving the first thread clean. Compound applied to female threads or used to excess can find its way into the valve, causing leakage.

Installation

Recommended Discharge Installation

Type "A" Installation

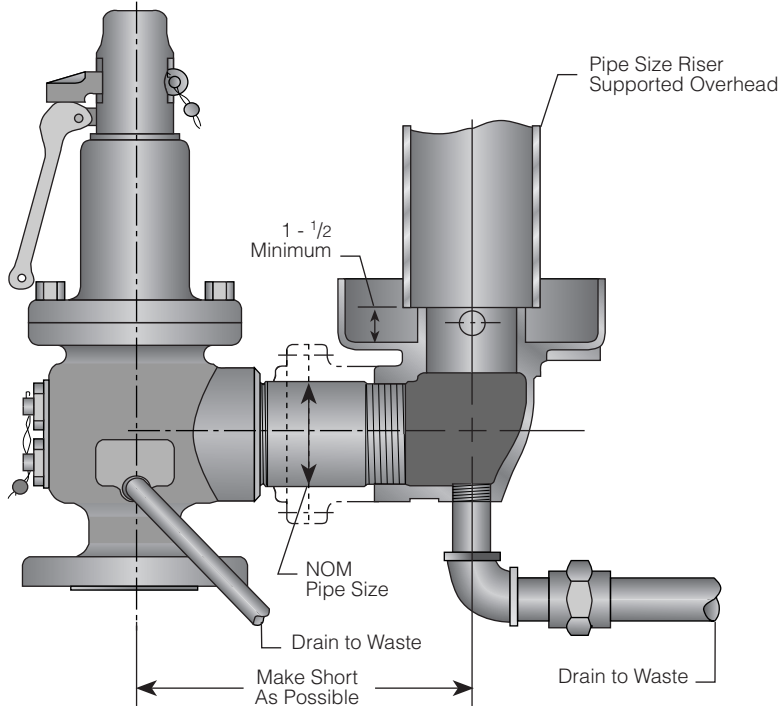

Type "B" Installation

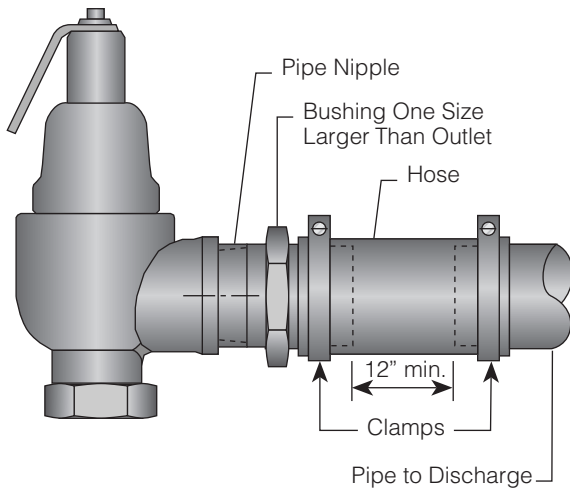

Type "C" Installation

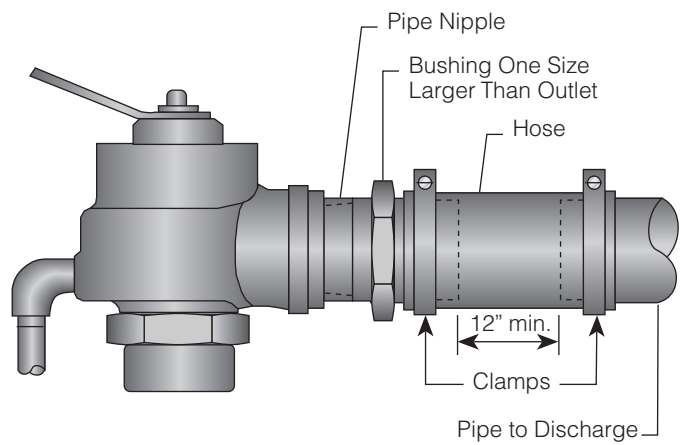

Maintenance

1. Develop a regular program of visual inspection, looking for clogged drains and discharge pipe, dirt build-up in and around the valve seat and broken or missing parts.
 2. Test the valve every two to six months (depending on valves' age and condition) preferably by raising the system pressure to the valves set pressure or operating the hand lever (see #3 in Operation).
 3. Do not paint, oil, or otherwise cover any interior or working parts of any safety valve. They do not require any lubrication or protective coating to work properly.
- When safety/relief valves require repair, service adjustments, or set pressure changes, work shall be accomplished by the manufacturer, or holders of "V," "UV," and/or "VR" stamps.

Guarantee

Pentair Valves & Controls LP, Black Mountain (Kunkle) warrants only that the goods delivered hereunder when paid for and properly installed, operated, and maintained shall be free from defects in material and workmanship under normal use and service for a period of twelve (12) months from the date of installation by the first user of such goods or eighteen (18) months from date of shipment from the factory, whichever period shall be first completed. The warranty hereunder granted does not apply to products or components (such as electric or pneumatic mechanisms) manufactured by other companies or to any goods manufactured by Pentair Valves & Controls LP, Black Mountain (Kunkle) that have been subjected to misuse, improper installation, improper storage or protection prior to installation or use, negligence by buyer or user, accident, corrosion, chemical attack, or misapplication, or that have been modified or repaired by unauthorized persons. Pentair Valves & Controls LP, Black Mountain's (Kunkle) obligation and buyer's remedy under this warranty are limited to: (a) correction, repair, or replacement, at Pentair Valves & Controls LP, Black Mountain's (Kunkle) option, of any defective unit of goods or (b) refund to buyer of the purchase price allocable to the defective unit of goods if Pentair Valves & Controls LP, Black Mountain (Kunkle) is unable to repair, replace or correct such defect in a reasonable time. Pentair Valves & Controls LP, Black Mountain's (Kunkle) liability under this warranty is conditioned upon buyer giving Pentair Valves & Controls LP, Black Mountain (Kunkle) immediate (but in any event within five (5) working days) written notice of any such defect. Any goods repaired or replaced hereunder shall continue to be

warranted for the remainder of the unexpired warranty period, if any. Any repair or replacement of defective goods or parts shall, at Pentair Valves & Controls LP, Black Mountain's (Kunkle) option, occur at its plant in Black Mountain, North Carolina and Pentair Valves & Controls LP, Black Mountain (Kunkle) shall reimburse buyer all reasonable freight costs incurred in transporting defective goods or parts to and from Pentair Valves & Controls LP, Black Mountain's (Kunkle) plant in the event of a valid warranty claim. In the event Pentair Valves & Controls LP, Black Mountain (Kunkle) elects to provide replacement goods or parts to buyer to repair defective goods, buyer agrees to install sold replacement parts or goods at its cost and, further, Pentair Valves & Controls LP, Black Mountain (Kunkle) shall in no event be liable for any labor or material costs of buyer with respect to de-installing or repairing defective goods or installing replacement parts or goods. Pentair Valves & Controls LP, Black Mountain (Kunkle) shall have the option of requiring the return of the defective goods or parts thereof, transportation prepaid, to establish the claim. Pentair Valves & Controls LP, Black Mountain (Kunkle) shall not be held liable for damages caused by delays in repair or replacement of any defective items. Certification by a separate writing as to compliance with specifications, blueprints, part numbers, quality tests or otherwise will not create any warranty by or obligation of Pentair Valves & Controls LP, Black Mountain (Kunkle). The provisions in Pentair Valves & Controls LP, Black Mountain's (Kunkle) literature and specifications are descriptive only, unless expressly stated as warranties. Except for the limited express warranty set forth in this

section, Pentair Valves & Controls LP, Black Mountain (Kunkle) expressly disclaims all warranties, express and implied, oral and written, including, without limitation, any warranties regarding services rendered ancillary hereto, and the implied warranties of merchantability and fitness for a particular purpose, whether arising from statute, common law, civil code, custom or otherwise. Pentair Valves & Controls LP, Black Mountain's (Kunkle) warranty obligations and buyer's remedies for breach of warranty, except as to title, are solely and exclusively as stated in this section. No modification or addition to this document with respect to the foregoing warranty by Pentair Valves & Controls LP, Black Mountain (Kunkle), either before or after execution of this document, shall be made except in writing by the President, Vice President, or Director, Sales and Marketing of Pentair Valves & Controls LP, Black Mountain (Kunkle).

Terms and Conditions of Sales

1. Offer or Acceptance. If this document constitutes an offer to sell by Seller (sometimes referred to as 'Pentair Valves & Controls LP, Black Mountain (Kunkle)'), Seller's offer is expressly subject to Buyer's acceptance of all the terms and conditions contained herein and no other, unless otherwise mutually agreed to by both Seller and Buyer in a writing signed by both parties, and any response by Buyer which constitutes additional or different terms shall not operate as an acceptance if such acceptance would vary, delete or add to the terms and conditions contained herein. If this document constitutes an acceptance by Seller of Buyer's offer to buy the goods or services specified on the face hereof, such acceptance is expressly subject to all the terms and conditions contained herein and no others, unless otherwise mutually agreed to by both Seller and Buyer in a writing signed by both parties. Any of Buyer's proposed terms and conditions which are in addition to or different from those contained herein are hereby objected to and shall be of no effect. Buyer will in any event be deemed to have assented to all terms and conditions contained herein if any part of the goods sold hereunder are accepted.
2. Shipping Dates. The shipping dates, if any, set forth herein are approximate and are not guaranteed. Seller shall not be liable for any loss or damage for delay, non-delivery or other impairment of performance due to the actions or inactions of government, military authority, or Buyer, or by any reason of "force major," which shall be deemed to mean all other causes whatsoever not reasonably within the control of Seller, including, but not limited to, acts of God, war, riot, sabotage, fires, floods, strikes, lockouts or other industrial disturbances, delays of carriers, and inability to secure materials, fuel labor, transportation or manufacturing facilities at Seller's expected prices. Any delay resulting from any such cause shall extend shipping dates correspondingly. Seller shall in no event be liable for any special, incidental or consequential damages arising from delay irrespective of the reason thereof, and receipt by Buyer shall constitute acceptance of delivery and waiver of any claims due to delay. Should delivery be delayed due to Buyer's actions or inactions, or should delivery be delayed at the request of Buyer, the selling price of the goods shall automatically escalate at the rate of two percent [2%] per month for the duration of the delay or in an amount equal to Seller's increased cost, whichever is greater.
3. Drawings. If drawings are submitted herewith they are submitted only to show the general style, arrangement and approximate dimensions of the goods offered. No work is to be based on drawings unless the drawings are certified. Dimensional drawings certified by Seller will be furnished if agreed. In no event will manufacturing or proprietary drawings be supplied.
4. Risk of Loss. Buyer bears the risk of loss for damage to or destruction of the goods from and after the time same said goods are delivered either to the carrier for shipment to Buyer or to the Buyer, whichever occurs first, and regardless of whether or not Buyer may have the right to reject or revoke acceptance of said goods.
5. Shipment. If delivery specified is F.O.B. Seller's plant with freight allowed, Buyer shall pay to Seller, in addition to the purchase price, any and all transportation charges (including insurance).
6. Taxes. In addition to any prices specified herein, Buyer shall pay the gross amount of any present or future sales, use, excise, value-added, or other tax (whether federal, state, local or foreign) applicable to the price, sale, possession, or delivery of any goods or services furnished hereunder or to the use thereof by Buyer, or Buyer shall furnish Seller with a tax-exemption certificate acceptable to the levying taxing authority.
7. Payments. Buyer shall make payment in full for all goods ordered hereunder prior to shipment to Buyer, unless Buyer has entered into and agreed to Seller's Standard Credit Application and Agreement, in which event such Agreement is incorporated herein by reference and made a part hereof, unless and until such Agreement is terminated. The prices specified are in USA currency.
8. Warranties; Remedies. Pentair Valves & Controls LP, Black Mountain (Kunkle) warrants only that the goods delivered hereunder when paid for and properly installed, operated, and maintained shall be free from defects in material and workmanship under normal use and service for a period of twelve (12) months from the date of installation by the first user of such goods or eighteen (18) months from date of shipment from the factory, whichever period shall be first completed. The warranty hereunder granted does not apply to products or components (such as electric or pneumatic mechanisms) manufactured by other companies or to any goods manufactured by Pentair Valves & Controls LP, Black Mountain (Kunkle) that have been subjected to misuse, improper installation, improper storage or protection prior to installation or use, negligence by Buyer or user, accident, corrosion, chemical attack or misapplication, or that have been modified or repaired by unauthorized persons. Pentair Valves & Controls LP, Black Mountain's (Kunkle) obligation and Buyer's remedy under this warranty are limited to: (a) correction, repair, or replacement, at Pentair Valves & Controls LP, Black Mountain's (Kunkle) option, of any defective unit of goods or (b) refund to Buyer of the purchase price allocable to the defective unit of goods if Pentair Valves & Controls LP, Black Mountain (Kunkle) is unable to repair, replace or correct such defect in a reasonable time. Pentair Valves & Controls LP, Black Mountain's (Kunkle) liability under this warranty is conditioned upon Buyer giving Pentair Valves & Controls LP, Black Mountain (Kunkle), immediate (but in any event within five (5) working days) written notice of any such defect. Any goods repaired or replaced of defective goods or parts shall, at Pentair Valves & Controls LP, Black Mountain's (Kunkle) option, occur at its plant in Houston, Texas and Pentair Valves & Controls LP, Black Mountain (Kunkle) shall reimburse Buyer all reasonable freight costs incurred in transporting defective goods or parts to and from Pentair Valves & Controls LP, Black Mountain's (Kunkle) plant in the event of a valid warranty claim. In the event Pentair Valves & Controls LP, Black Mountain (Kunkle) elects to provide replacement good or parts to buyer to repair defective goods, Buyer agrees to install said replacement parts or goods at its cost and, further, Pentair Valves & Controls LP, Black Mountain (Kunkle), shall in no event be liable for any labor or material costs of Buyer with respect to de-installing or repairing defective goods or installing replacement parts or goods. Pentair Valves & Controls LP, Black Mountain (Kunkle) shall have the option of requiring the return of the defective goods or parts thereof, transportation prepaid, to establish the claim. Pentair Valves & Controls LP, Black Mountain (Kunkle) shall not be held liable for damages caused by delays in repair or replacement of any defective items. Certification by a separate writing as to compliance with specifications, blueprints, part numbers, quality test or otherwise will not create any warranty by or obligation of Pentair Valves & Controls LP, Black Mountain (Kunkle). The provisions in Pentair Valves & Controls LP, Black Mountain's (Kunkle) literature and specifications are descriptive only unless expressly stated as warranties. EXCEPT FOR THE LIMITED EXPRESS WARRANTY SET FORTH IN THIS SECTION, KUNKLE EXPRESSLY DISCLAIMS ALL WARRANTIES, EXPRESS AND IMPLIED, ORAL AND WRITTEN, INCLUDING, WITHOUT LIMITATION, AND FITNESS FOR A PARTICULAR PURPOSE, WHETHER ARISING FROM STATUTE, COMMON LAW, CIVIL CODE, CUSTOM OR OTHERWISE. KUNKLE'S WARRANTY OBLIGATIONS AND BUYER'S REMEDIES FOR BREACH OF WARRANTY, EXCEPT AS TO TITLE, ARE SOLELY AND EXCLUSIVELY AS STATED IN THIS SECTION. No modification or addition to this document with respect to the foregoing warranty by Pentair Valves & Controls LP, Black Mountain (Kunkle) either before or after execution of this document, shall be made except in writing by the President or a Vice President of Pentair Valves & Controls LP, Black Mountain (Kunkle).
9. Limitation of Liability. In any event, the total liability of Pentair Valves & Controls LP, Black Mountain (Kunkle) arising from any cause of action or claim whatsoever, whether (a) in contract, (b) in tort, (including negligence, whether sole, joint, contributory, concurrent or antipollution law or regulation), (c) connected with any toxic or hazardous substance or constituent, (d) arising out of any representation or instruction, or under any warranty, (e) or otherwise, arising out of, connected with, or resulting from the design, manufacture, sale, resale, delivery, repair, replacement or use of any goods or the furnishing of any service shall in no event exceed the price allocable to and paid to Pentair Valves &

Terms and Conditions of Sales

- Controls LP, Black Mountain (Kunkle) for the individual unit of goods or services or part thereof which gives rise to the cause of action or claim. In no event shall Pentair Valves & Controls LP, Black Mountain (Kunkle) or its affiliates be liable for any special, indirect, incidental or consequential damages whenever occurring including, but not limited to, damages for loss of use of plant or property, damage to or destruction of equipment, downtime cost, cost of capital, economic loss, loss of good will, labor cost, loss of profits or revenues, or claims resulting from contracts between Buyer, its customers and/or suppliers, regardless of whether any of the foregoing arises from this document or Pentair Valves & Controls LP, Black Mountain (Kunkle) by any human being for personal injury or wrongful death. Pentair Valves & Controls LP, Black Mountain (Kunkle) and Buyer acknowledge and agree that the exclusions of remedies and limitations of liability and damages herein reflect a bargained-for allocation and limitation of risk, liability and damages. Pentair Valves & Controls LP, Black Mountain (Kunkle) will not defend, indemnify or hold harmless Buyer or others for any claim, expense or liability. This Section shall apply notwithstanding any other provision of this document.
10. Limitation of Liability to Third-Party Purchases. Prior to Buyer's transfer or sale of any goods sold pursuant hereto, or the transfer or sale of any interest in such goods, Buyer shall notify the Transferee of the full text of Sections 8 and 9 hereof in writing and shall provide Seller with written acknowledgment and acceptance by the transferee of the terms of Sections 8 and 9 hereof. Further, Buyer shall incorporate verbatim Sections 8 and 9 hereof in any contract between Buyer and any Transferee concerning any such transfer or sale. Buyer shall also include a written copy of Section 8 and 9 hereof with any goods covered hereby that are transferred or sold to a transferee. IF TRANSFER IS MADE CONTRARY TO THE PROVISIONS OF THIS SECTION 10, BUYER SHALL, IN ADDITION TO ANY OTHER LEGAL OR EQUITABLE RIGHTS OF SELLER, INDEMNIFY SELLER AGAINST ANY LIABILITIES, CLAIMS, COSTS, DAMAGES AND ATTORNEY'S FEES INCURRED BY SELLER IN EXCESS OF THOSE SET FORTH IN SECTIONS 8 AND 9 HEREOF. This Section 10 shall apply notwithstanding any other provisions of this document.
11. Returns; Cancellations. No goods may be returned except on prior written approval of Seller. Orders placed with and accepted by Seller may not be canceled except with the written consent of Seller prior to shipment and Buyer's acceptance of Seller's cancellation charges which shall protect Seller against all costs and losses. Seller shall have the right to cancel the sale of any or all of the goods sold hereunder, without liability to Buyer except for the refund of monies already paid hereunder, the event manufacture or sale of the goods is or becomes technically or economically impractical.
12. Product Modification. Seller reserves the right to discontinue the manufacture of, or charge or modify the design and/or construction of goods sold pursuant to this document for the purpose of product improvement, without incurring any obligation to Buyer with respect thereto.
13. Patents. Seller agrees as its option, to defend at its safe cost and expense, and to pay any damages and cost awarded against Buyer, from any claim, suit or proceeding against Buyer to the extent such claim, suit or proceeding is based on an allegation that goods manufactured by Seller and delivered to Buyer hereunder infringe any United States letter patent, provided: (1) Seller is notified promptly in writing by Buyer of any such claim, suit or proceeding; (2) Seller is given information and assistance by Buyer as may be requested by Seller; and (3) Seller is given full authority (including authority to settle) by Buyer to conduct such defense as Seller deems appropriate. Seller's obligation under this Section does not apply to any goods the designs, instructions and/or specifications for which are partially or completely supplied by Buyer or to any claim, suit or proceeding in which the alleged infringement results from alteration of goods; use of goods for purposes other than those for which the goods were intended, or use of the goods in combination with products not manufactured by Seller. If in any suit covered by this Section, the use of goods is enjoined, Seller shall at its option and sole cost and expense either: (a) procure for Buyer the right to continue using the goods; (b) replace the goods with non-infringing goods; (c) modify the goods to be non-infringing; or (d) refund to Buyer the purchase price of the goods and transportation costs related thereto. Seller shall have no liability with respect to patent or trademark rights of countries foreign to the USA. The foregoing shall be Seller's sole and entire liability for patent infringement by the goods furnished pursuant hereto.
14. Data. Buyer agrees that all drawings, prints and other technical material (collectively 'Materials') which Seller provides to Buyer, whether prepared by Seller or by third parties under contract to Seller, contain data which embody trade secrets and confidential know-how of commercial value to Seller or to third parties under contract to Seller. Buyer agrees that Buyer and its agents and employees; (a) will keep confidential all such Materials; (b) will not disclose such Materials to any other person, corporate division or entity, except to employees of Buyer who need such Materials in order to perform Buyer's obligations hereunder; (c) will not use such Materials, except in connection with goods supplied hereunder; and (d) will not sell, lease, loan or permit any other person, corporate division or entity to use such Materials for any purpose, without Seller's prior written consent. Nothing herein shall restrict use of data or information available to the general public.
15. Applicable Law: Section Headlines. This document shall be deemed to have been executed and entered into the State of Texas, USA, and this document, and its formation, operation and performance, shall be governed, construed, performed and enforced in accordance with the substantive laws of the State of Texas, USA. The parties hereto agree that any civil action or lawsuit arising out of this document or the subject matter hereof shall be brought and maintained solely in state or federal courts located in Harris County, Texas, USA, and Buyer and Seller each hereby consents and submits to the personal jurisdiction of said courts. Any action or claim in any part arising out of or related to this document or the subject matter hereof, may be commenced or brought within one (1) year from the date the claim or action shall first arise or accrue, or be barred forever. The Section headings herein contained are for ease of reference only and shall not be construed to be part of this document.
16. Merger. Seller and Buyer agree that there are no understandings, agreements, representations or warranties between or by either of them, either oral or written, relative to the goods or services sold, pursuant hereto, including any made in or implied from past dealings, relative to the goods or services sold pursuant hereto, except those that are fully expressed herein. The provisions of this document supercede and control any previous understanding or agreement between the parties with respect to the subject matter hereof and this document is an expression of the complete and final understanding of the parties. Any representation, promise, course of dealing or trade usage not contained or referenced herein will not be binding on the parties hereto. Seller's branch managers or sales representatives, distributors, and dealers appointed by Seller are not authorized to make modifications, waivers or changes in or to these terms and conditions of sale. Buyer represents and agrees that it is Buyer's sole obligation and responsibility to determine the suitability of the goods for Buyer's use and application and any statements made by Seller's salespersons are opinion only and not representations or warranties of Seller and will not be relied on by the Buyer.



5500 WAYZATA BLVD # 800, MINNEAPOLIS, MN 55416 WWW.PENTAIR.COM/VALVES
KUNKLE FACILITY PHONE: 1-828-669-3700 • WWW.KUNKLEVALVE.COM

All Pentair trademarks and logos are owned by Pentair, Inc. All other brand or product names are trademarks or registered marks of their respective owners. Because we are continuously improving our products and services, Pentair reserves the right to change specifications without prior notice. Pentair is an equal opportunity employer.