

APPROVAL

BY: _____ DATE: _____

- APPROVED, PROCEED WITH FABRICATION
- APPROVED AS NOTED, PROCEED WITH FABRICATION IN ACCORDANCE WITH COMMENTS
- DISAPPROVED, DO NOT FABRICATE

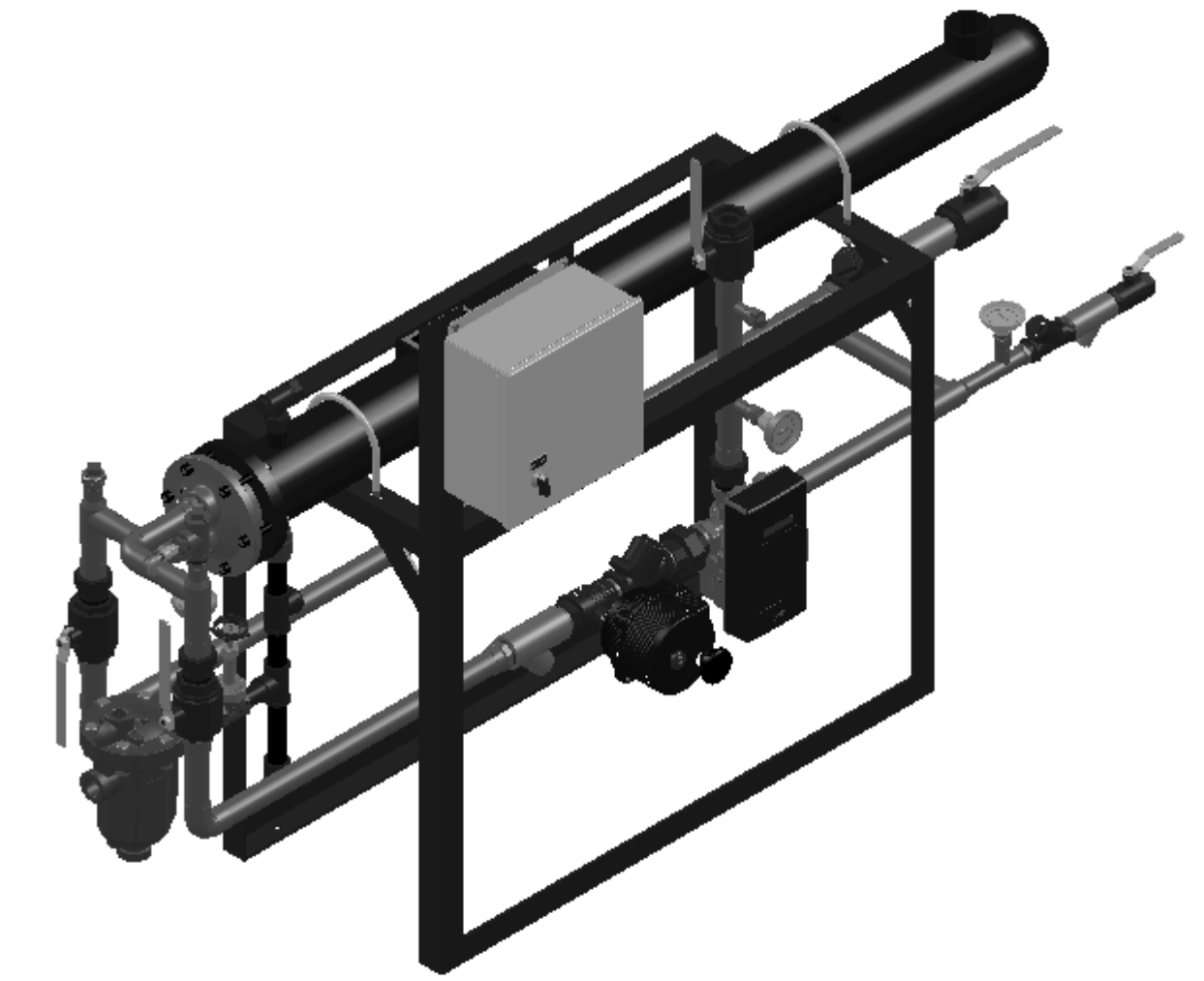

DIGITAL FLO STEAM/WATER SHELL & TUBE HEAT EXCHANGER DOUBLE WALL

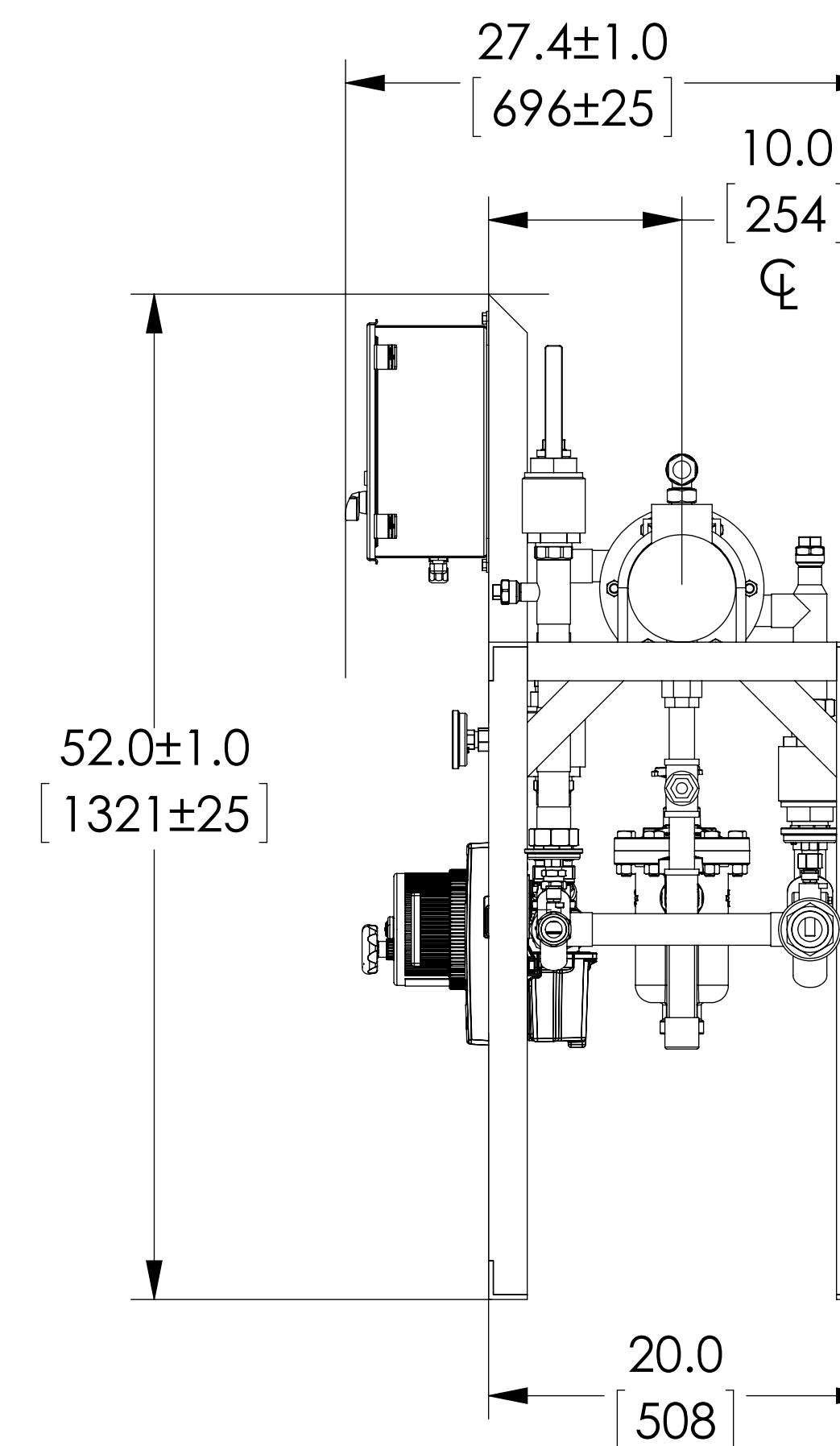
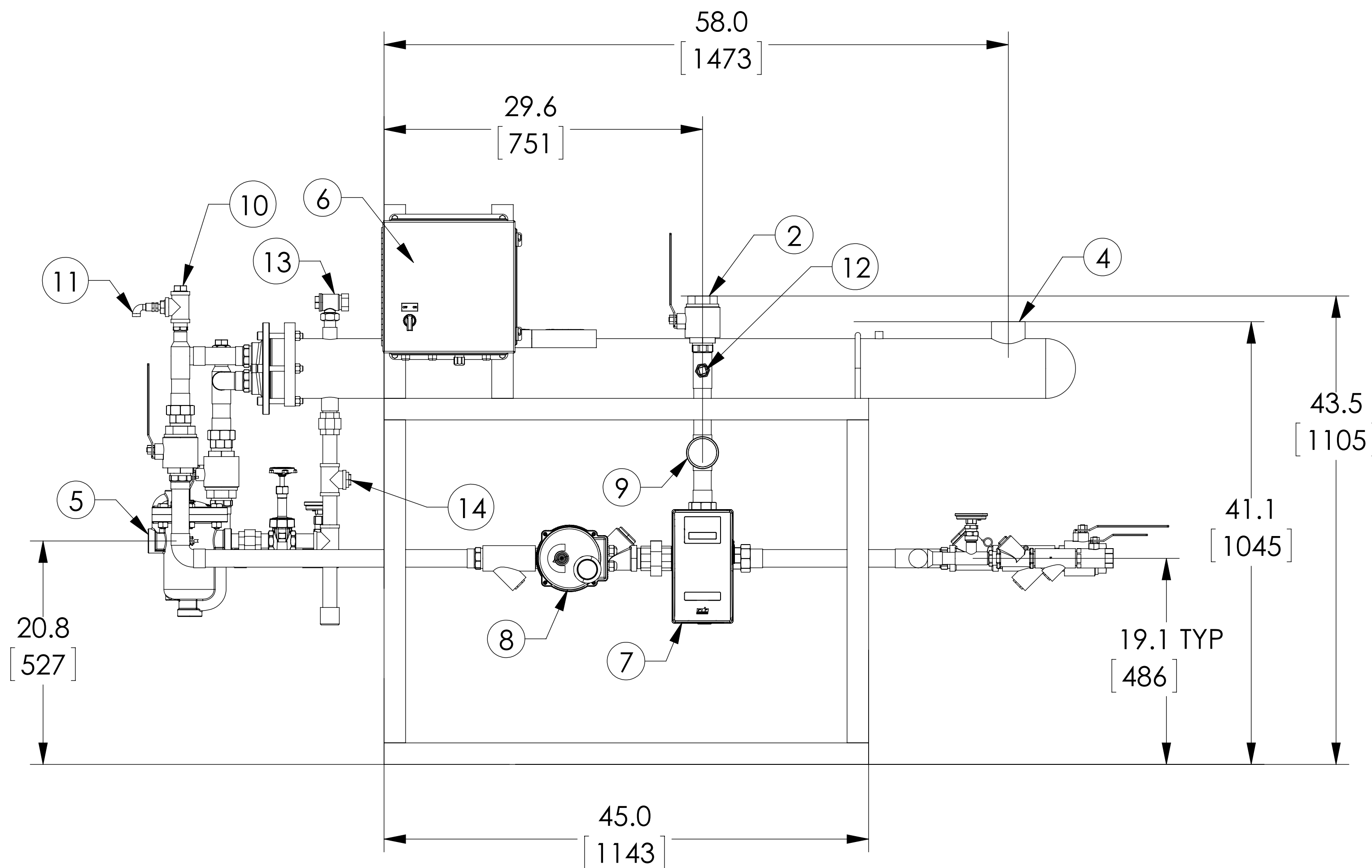
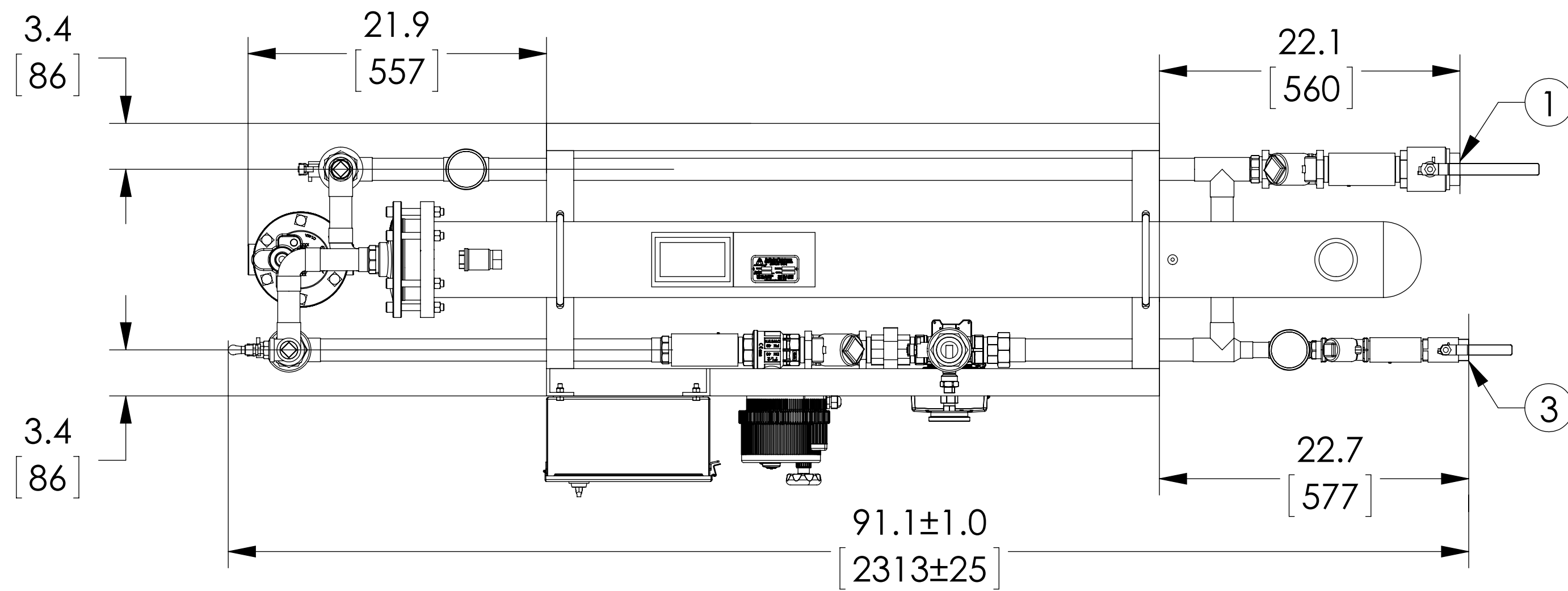

PROJECT NAME :

TAG :

ITEM	DESCRIPTION	CONNECTION
1	COLD WATER INLET	1-1/2" NPT
2	MIXED WATER OUTLET	1-1/2" NPT
3	RECIRC WATER INLET	1" NPT
4	STEAM INLET	2-1/2" NPT
5	CONDENSATE OUTLET	1" NPT 813 IB
6	ELECTRICAL PANEL/BRAINSCAN	110VAC @ 1.2A
7	DRV40	1-1/2" NPT
8	N.C. ACTUATED BALL VALVE SAFETY SHUT OFF	1-1/2" NPT
9	THERMOMETER (3)	
10	CIP CONNECTION (2)	1" NPT
11	SRV(PRESSURE) PIPE TO DRAIN	1" NPT
12	SRV(CONNECTION FOR USER SUPPLIED T&P)	3/4" NPT
13	AIR VENT	3/4" NPT
14	VACUUM BREAKER	1/2" NPT
ITEM	MATERIAL	
PIPING	COPPER TYPE "L"	
EXCHANGER SHELL MATL.	CARBON STEEL	
EXCHANGER TUBE MATL.	ADMIRALTY BRASS	
	DRV SET POINT	85°F

NOTE(S):

- ALL DIMENSIONS +/- 0.5[13] UNLESS OTHERWISE SHOWN.
- COMPLETE ASSEMBLY LEAD FREE COMPLIANT - THE WETTED SURFACE OF THIS PRODUCT CONTACTED BY CONSUMABLE WATER CONTAINS LESS THAN ONE QUARTER OF ONE PERCENT (0.25%) OF LEAD BY WEIGHT.
- PACKAGE INCLUDES ALL REQUIRED INLET CHECK VALVES AND STRAINERS ON DOMESTIC SIDE.
- DRV, SAFETY SHUT OFF AND ELECTRICAL PANEL ARE PREWIRED TO PROVIDE A SINGLE ELECTRICAL LANDING POINT AT THE PANEL.
- ITEM # 11 IS 1/4[6.4] PIPE TO DRAIN IF FACTORY PRESS RELIEF VALVE IS USED.

DO NOT SCALE DRAWING TOLERANCES UNLESS OTHERWISE SPECIFIED	
DIMENSIONING ENGLISH [mm]	
FRACTIONAL ± 1/64	ANGULAR: ± 2
DECIMAL .XXX ± .005	.XXX ± .005 .010
.XX ± .015	.XX ± .015 .10
.X ± .03	.X ± .03 .3

NAME	DATE
DRAWN: CFG	11/18/2013
RELEASED: SALES	

ARMSTRONG INTERNATIONAL Copyright © 2010 ARMSTRONG INTERNATIONAL, INC.	
DF535DW40BS 1-1/2 NPT 1-1/2 NPT 1 NPT CPR	
CONFIG# (C-118802)	
MATERIAL	SHEET 1 OF 1
REV	DWG. D589723