

DIMENSIONS & DATA CERTIFIED FOR:

Representative:

Order:

Customer:

Order:

Project:

Requirements:

By:

Date:

DIMENSION	A	B
0" FILL HEAD	25	28
6" FILL HEAD	31	34
12" FILL HEAD	37	40

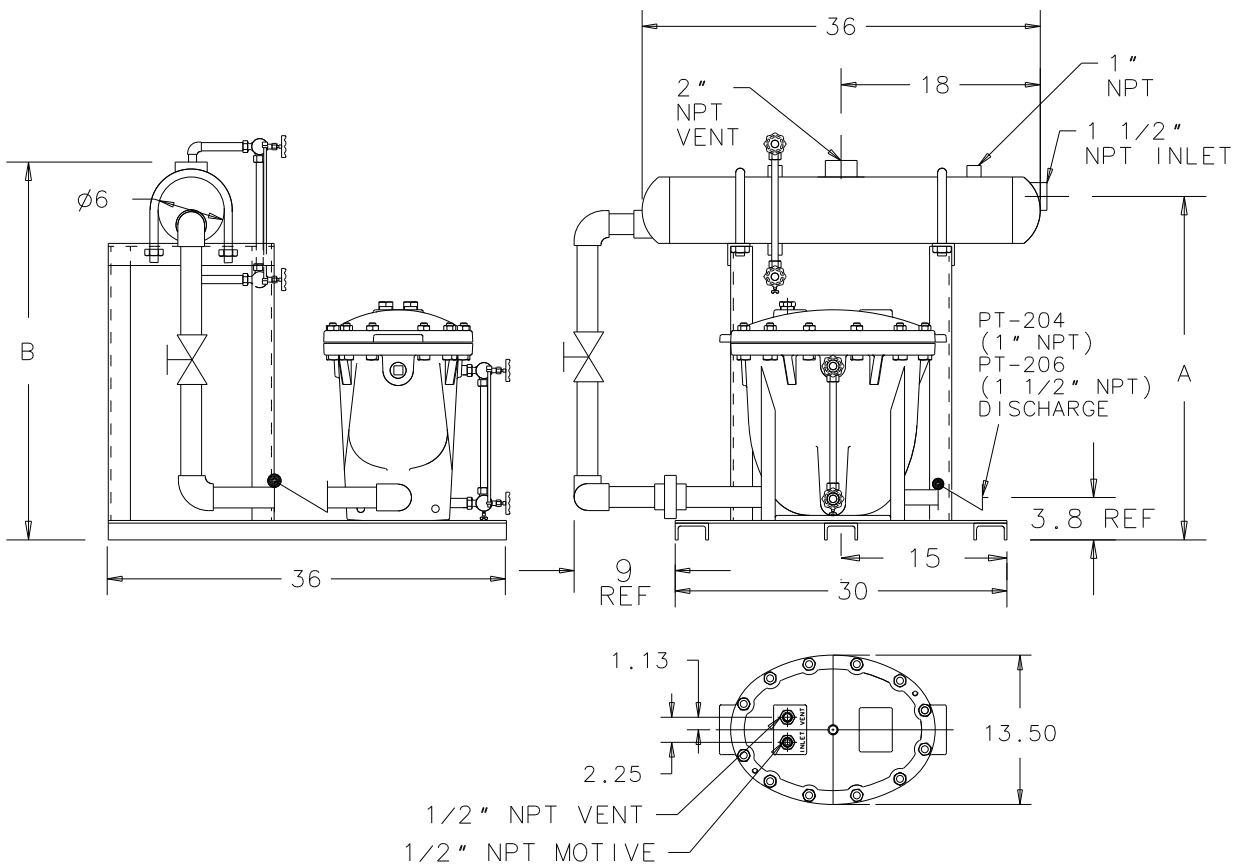

NOTES:

1. DRAWING SHOWS OPTIONAL GAUGE GLASSES.
2. RECEIVER ASME CODE 150 PSI
3. RECEIVER VOLUME= APPROX. 4 GALLONS
4. SEE DRAWING CDF1038 FOR RECEIVER SIZING
5. FILL HEAD MUST BE SPECIFIED

 Armstrong Condensate Management Group Three Rivers, MI. 49093 Telephone (269) 279-3601 Fax (269) 279-3150 Posted on www.armstronginternational.com		
Product	CDF No.	Date
SPT-200LBRP-6	CDF 1071	06/21/06
		Rev. A