

# DIMENSIONS & DATA CERTIFIED FOR:

Representative:

Order:

Customer:

Order:

Project:

Requirements:

By:

Date:

DIMENSION	A	B
0" FILL HEAD	20	23
6" FILL HEAD	26	29
12" FILL HEAD	32	35

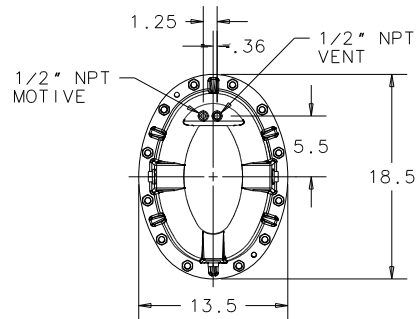
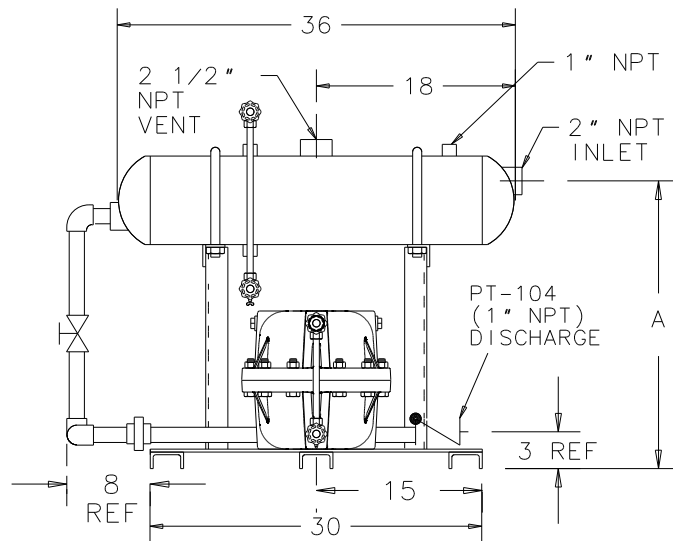
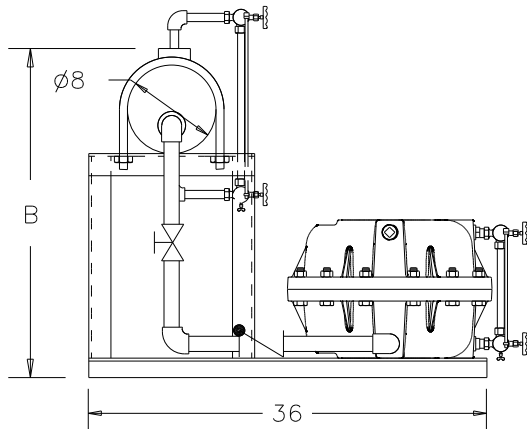

**NOTES:**

1. DRAWING SHOWS OPTIONAL GAUGE GLASSES.
2. RECEIVER ASME CODE 150 PSIG
3. RECEIVER VOLUME = APPROX. 7 GALLONS
4. SEE DRAWING CDF1038 FOR RECEIVER SIZING
5. FILL HEAD MUST BE SPECIFIED



Armstrong Condensate Management Group  
 Three Rivers, MI. 49093  
 Telephone (269) 279-3601  
 Fax (269) 279-3150  
 Posted on [www.armstronginternational.com](http://www.armstronginternational.com)

Product	CDF No.	Date
SPT-104LBRP-8	CDF1068	06/21/06
		Rev. A