

APPROVAL

BY: _____ DATE: _____

- APPROVED, PROCEED WITH FABRICATION
- APPROVED AS NOTED, PROCEED WITH FABRICATION IN ACCORDANCE WITH COMMENTS
- DISAPPROVED, DO NOT FABRICATE

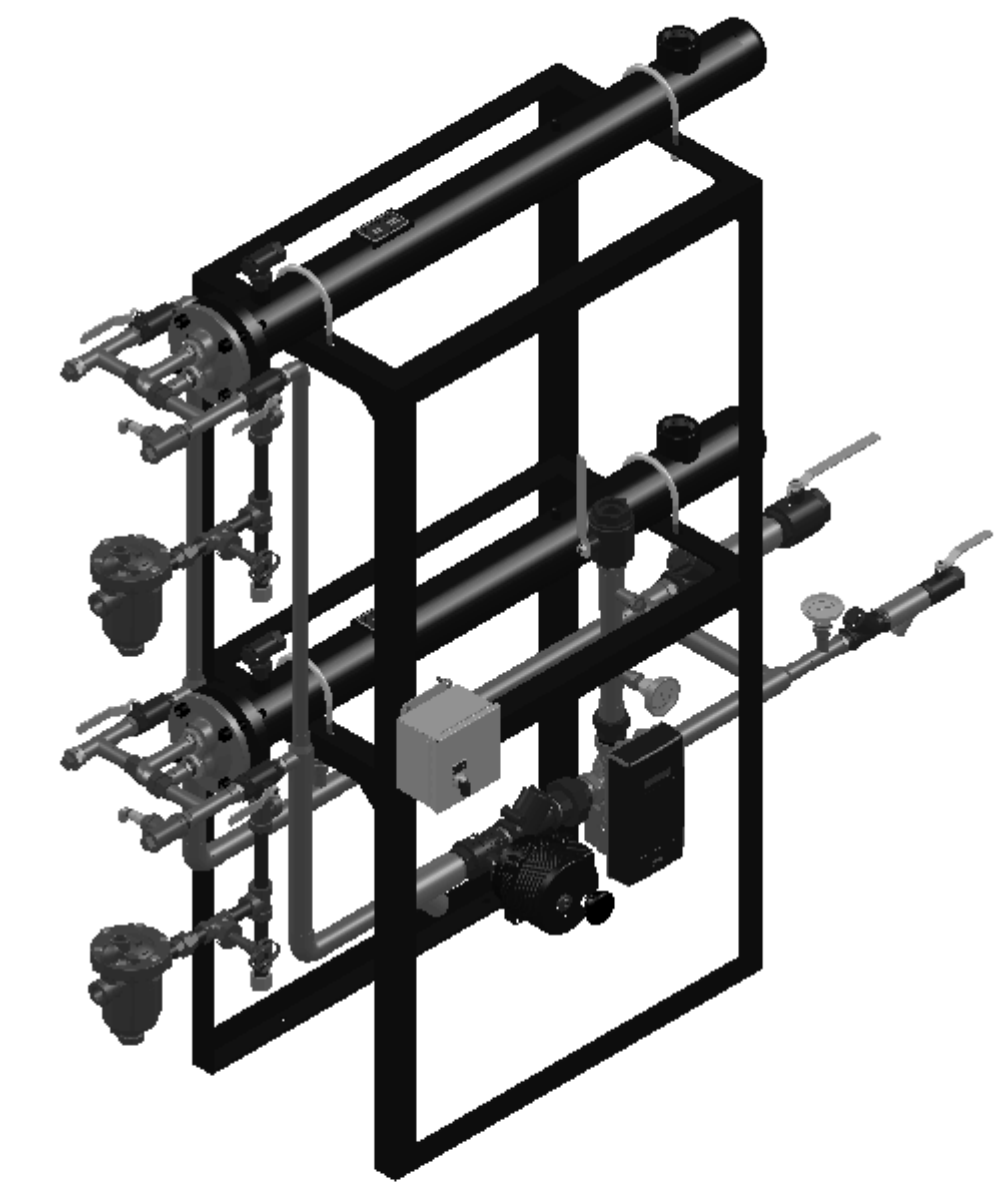

DIGITAL FLO STEAM/WATER SHELL & TUBE HEAT EXCHANGER SINGLE WALL

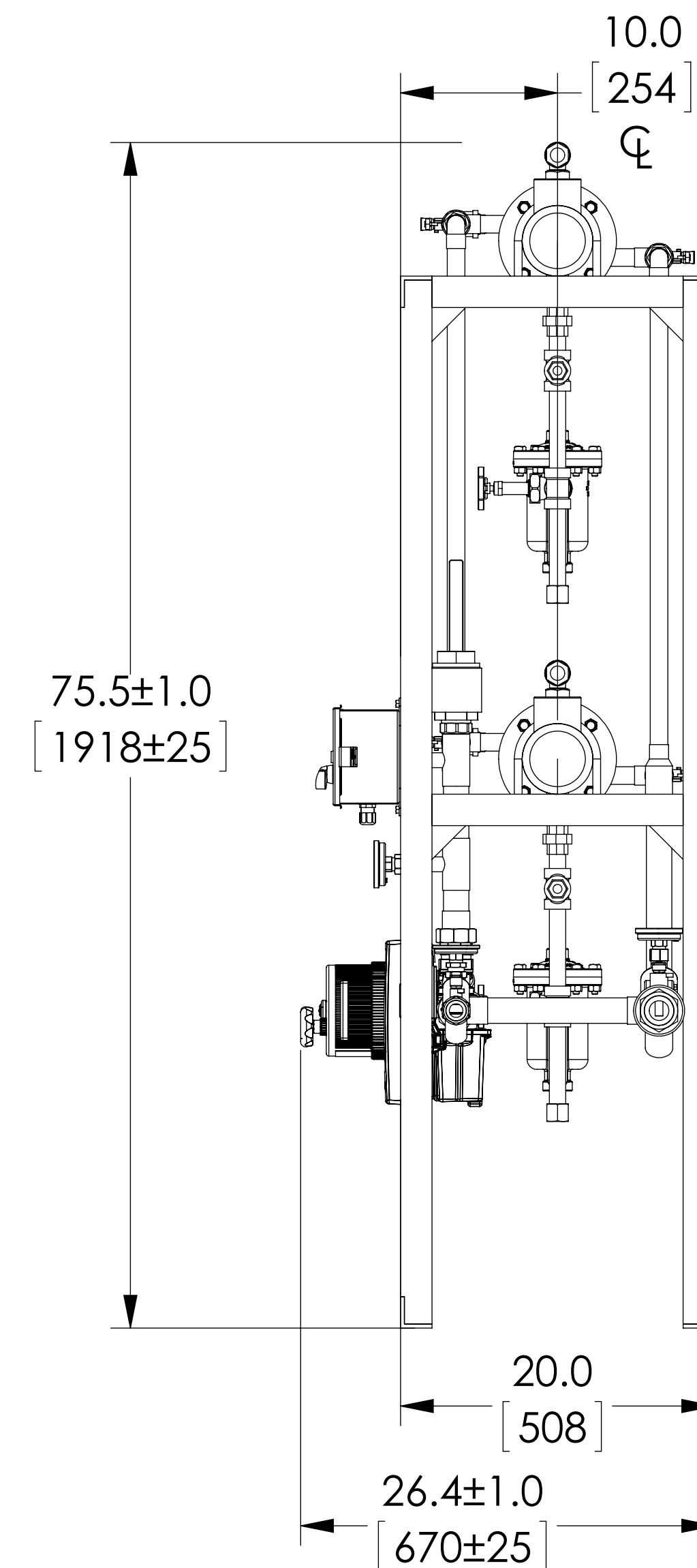
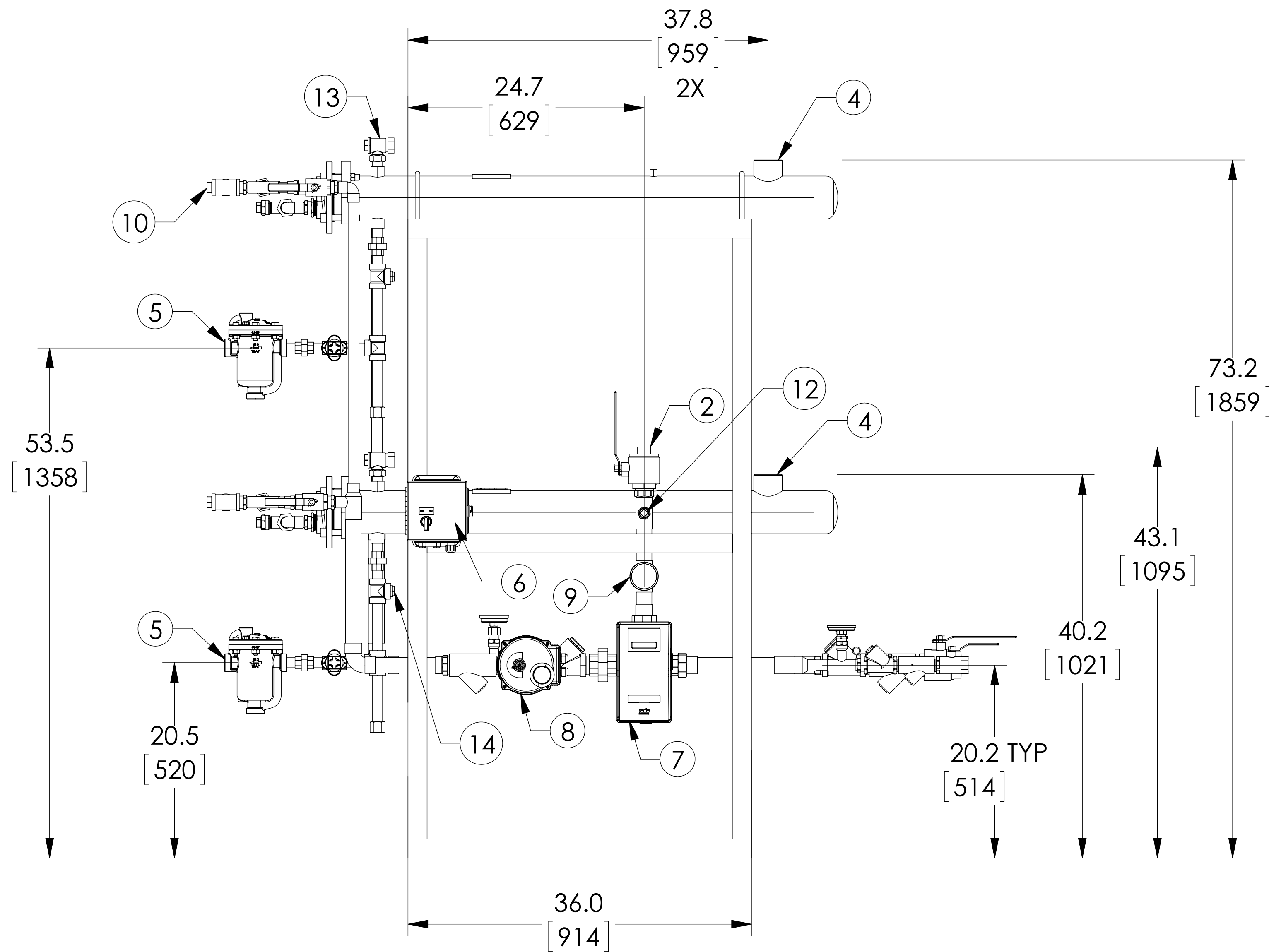
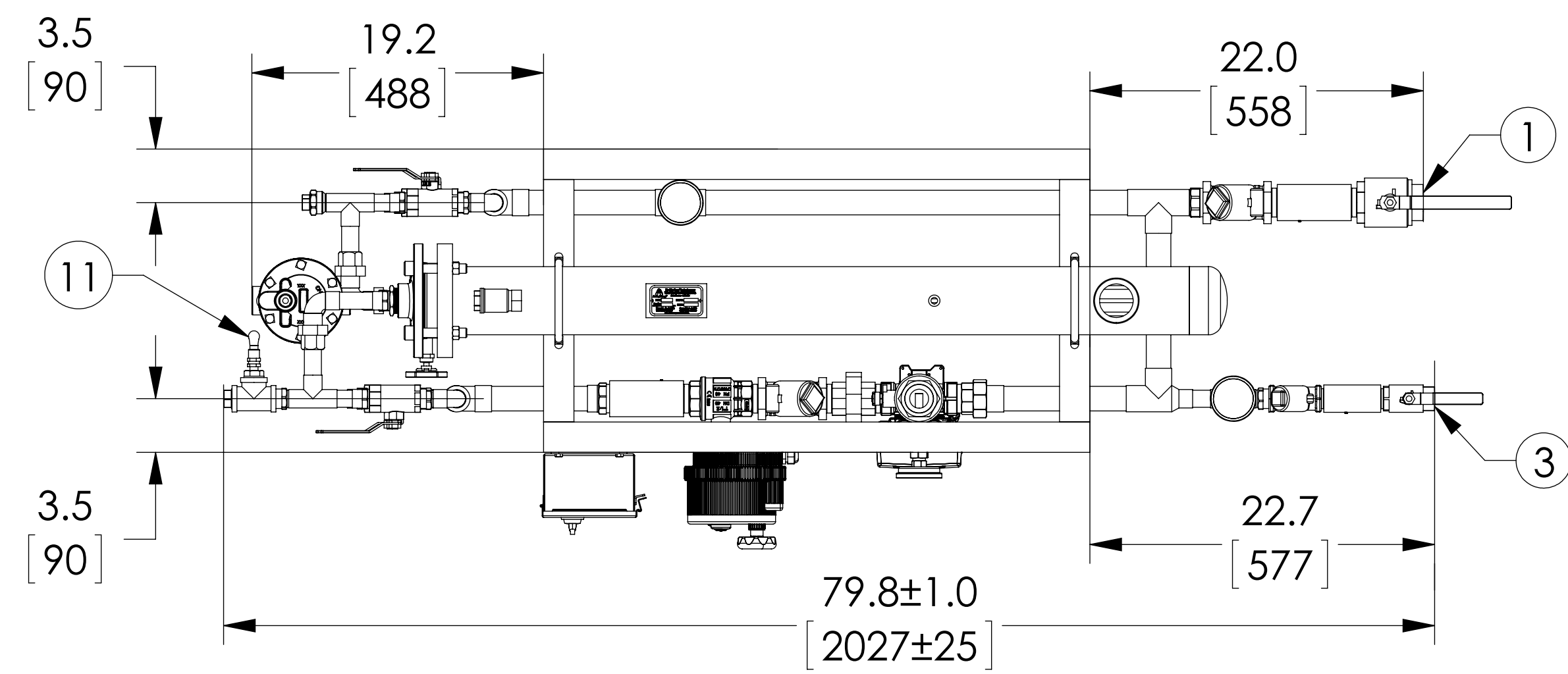

PROJECT NAME :

TAG :

ITEM	DESCRIPTION	CONNECTION
1	COLD WATER INLET	1-1/2" NPT
2	MIXED WATER OUTLET	1-1/2" NPT
3	RECIRC WATER INLET	1" NPT
4	STEAM INLET	2" NPT
5	CONDENSATE OUTLET	3/4" NPT 812 IB
6	ELECTRICAL PANEL	110VAC @ 0.7A
7	DRV40	1-1/2" NPT
8	N.C. ACTUATED BALL VALVE SAFETY SHUT OFF	1-1/2" NPT
9	THERMOMETER (3)	
10	CIP CONNECTION (4)	1" NPT
11	SRV(PRESSURE) PIPE TO DRAIN (2)	1" NPT
12	SRV(CONNECTION FOR USER SUPPLIED T&P)	3/4" NPT
13	AIR VENT (2)	3/4" NPT
14	VACUUM BREAKER (2)	1/2" NPT
ITEM	MATERIAL	
	PIPING	COPPER TYPE "L"
	EXCHANGER SHELL MATL.	CARBON STEEL
	EXCHANGER TUBE MATL.	ADMIRALTY BRASS
	DRV SET POINT	85°F

NOTE(S):

1. ALL DIMENSIONS +/- 0.5[13] UNLESS OTHERWISE SHOWN.
2. COMPLETE ASSEMBLY LEAD FREE COMPLIANT - THE WETTED SURFACE OF THIS PRODUCT CONTACTED BY CONSUMABLE WATER CONTAINS LESS THAN ONE QUARTER OF ONE PERCENT (0.25%) OF LEAD BY WEIGHT.
3. PACKAGE INCLUDES ALL REQUIRED INLET CHECK VALVES AND STRAINERS ON DOMESTIC SIDE.
4. DRV, SAFETY SHUT OFF AND ELECTRICAL PANEL ARE PREWIRED TO PROVIDE A SINGLE ELECTRICAL LANDING POINT AT THE PANEL.
5. ITEM # 11 IS 1/4[6.4] PIPE TO DRAIN IF FACTORY PRESS RELIEF VALVE IS USED.

DO NOT SCALE DRAWING TOLERANCES UNLESS OTHERWISE SPECIFIED	
DIMENSIONING ENGLISH [mm]	
FRACTIONAL ± 1/64	ANGULAR: ± 2
DECIMAL .XXX ± .005	.XX ± .015
.XX ± .015	.X ± .3

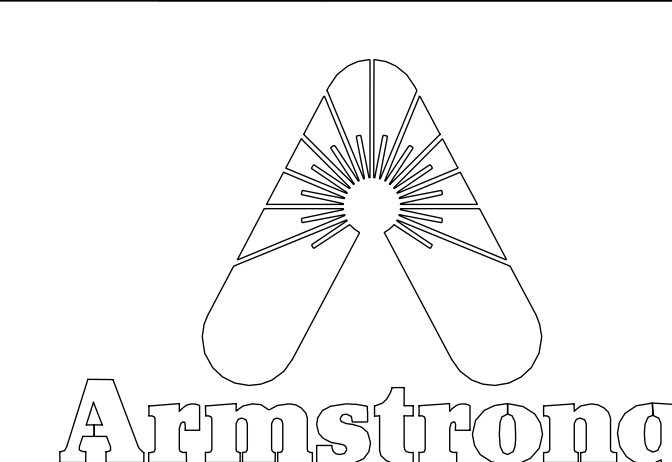
Armstrong®

	NAME	DATE
DRAWN	CFG	11/18/2013
RELEASED	SALES	

ARMSTRONG INTERNATIONAL
 Copyright © 2010 ARMSTRONG INTERNATIONAL, INC.

DF415P40 1-1/2 NPT 1-1/2 NPT 1 NPT CPR

CONFIG# (C-118755)

MATERIAL	SHEET 1 OF 1
REV	DWG. D589682