

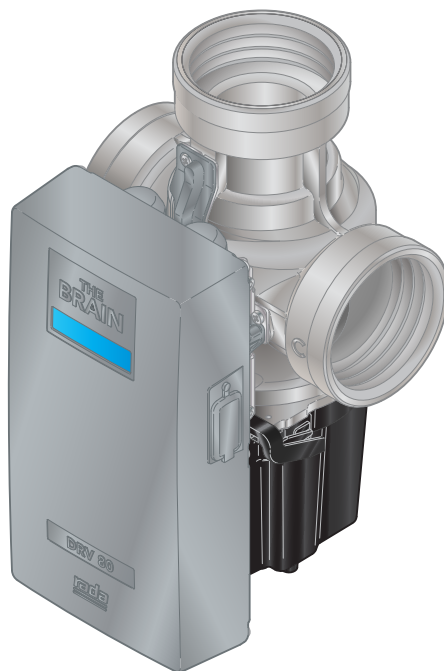

The Brain[®] DRV80 Digital Recirculation Valve



The installation and service must be performed by a qualified installer.
For further information, please call our technical department at +32 4240 9090.



Armstrong International
Parc Industriel Des Hants-Sarts, 2ème Avenue No. 4, Haerstal, B-4040, Belgium
armstronginternational.com/brain

Keep this manual with installation
for future reference.

DRV80 Digital Recirculation Mixing Valve

Contents

Introduction.....	3	Preventative Maintenance and Fitting	
Safety.....	3	Spare Parts.....	42
General Advisory.....	4	DRV80 Disassembly	43
Data Storage	4	Electronics Module.....	44
Patents.....	4	PCB Connections	47
Single DRV80 Pack Contents.....	5	DRV	48
DRV80 Dimensions.....	6	Troubleshooting.....	58
Specifications	8	Contents.....	58
Standards and Codes.....	8	DRV80 Display Errors.....	59
Default Settings	9	Common Faults	62
Installation.....	10	Limited Warranty and Remedy	72
General	10		
Installation Requirements	11		
Piping Diagrams	12		
Installation DRV80	16		
Commissioning.....	18		
Operation.....	20		
Control Software.....	21		
Introduction.....	21		
COM Port.....	22		
DRV Information	24		
Temperatures.....	25		
Setpoints	26		
Setpoints - Explained.....	28		
Alerts - Explained	29		
Preset Display Alerts	31		
Disinfection	32		
Disinfection Step by Step - 1	36		
Disinfection Step by Step - 2.....	37		
Options.....	38		
DRV80 Display Alerts	39		
DRV80 Error Messages	39		
Connectivity	40		
System Performance	41		



Armstrong International
Parc Industriel Des Hants-Sarts, 2ème Avenue No. 4, Haerstal, B-4040, Belgium
armstronginternational.com/brain

Introduction

The Brain® DRV80 is a registered trademark of Armstrong Hot Water Group, a division of Armstrong International.

DRV80 features Rada Technology, Rada is a registered trademark of Kohler Mira Limited of Cheltenham, England.

The DRV80 is a digital recirculating valve for use as part of a warm water recirculation system within a commercial installation.

A dedicated PC / Laptop with Microsoft Windows based control program can monitor and control temperature limits, disinfection and temperature warning alerts. This product can be linked to external control and monitoring devices such as a Building Management System. Data connections can be made via USB plug-in or Serial Port.

DRV80 Control Software and USB Cable Drivers are available to download and update at www.armstronginternational.com/brain

Safety

Icon Legend

If instructions are not followed:



- injury or death and property damage are **imminent**



- injury or death and property damage are **possible**



- potential property damage, expensive repairs, and / or voiding the warranty may result



- Applicable codes must be followed and supersede any other instructions. Generally applicable codes in the US include:
 - IPC (International Plumbing Code)
- Read this manual
- Improper installation or operation may cause a flood resulting in property damage, personal injury, or death. Armstrong strongly recommends that a qualified installer be used.
- Service must be performed by a qualified person.
- Improper installation, start-up, operation, maintenance, or service may void the warranty.



Hot water or metal may cause scald burns. Skin exposure to 60°C water or metal for only five seconds may cause a second degree burn.



Armstrong International
Parc Industriel Des Hants-Sarts, 2ème Avenue No. 4, Haerstal, B-4040, Belgium
armstronginternational.com/brain

General Advisory

The use of the word 'failsafe' to describe the function of any hot and cold water mixing valve is both incorrect and misleading. This DRV (*Digital Recirculation Valve*) incorporates additional shut-off devices to improve the level of safety however, in keeping with every other mechanism it cannot be considered as being functionally infallible.

Where chloramine / chlorine disinfection is practiced, **DO NOT** exceed a chloramine / chlorine concentration of **50 mg/l (ppm)** in water, per one hour dwell time. Such procedures must be conducted strictly in accordance with the information supplied with the disinfectant and with all relevant Guidelines / Approved Codes of Practice. Water must have levels of chloramine / chlorine lower than or equal to 4mg/l (ppm) for continual usage.

Data Storage

Armstrong International shall not accept liability in contract, tort (including negligence or otherwise) for any loss of profits, business or anticipated savings, or loss or corruption of data, or any indirect or consequential loss arising out of the customer's use of DRV80. The customer shall be solely responsible for the independent backup of all data / information stored on DRV80. Notwithstanding the foregoing, none of the exclusions and limitations stated above are intended to limit any rights the customer may have under local law or other statutory rights which may not be excluded.

Patents

GB - 2 421 297 2 437 891
US - 7669776 8043556
PCT - PCT/GB2006/000159
European - 06702758.1
India - 1231/MUMNP/2007
Australia - 2006207367
Canada - 2595064
China - ZL200680005853.8
Japan - 4933451



Armstrong International
Parc Industriel Des Hants-Sarts, 2ème Avenue No. 4, Haerstal, B-4040, Belgium
armstronginternational.com/brain

Single DRV80 Pack Contents

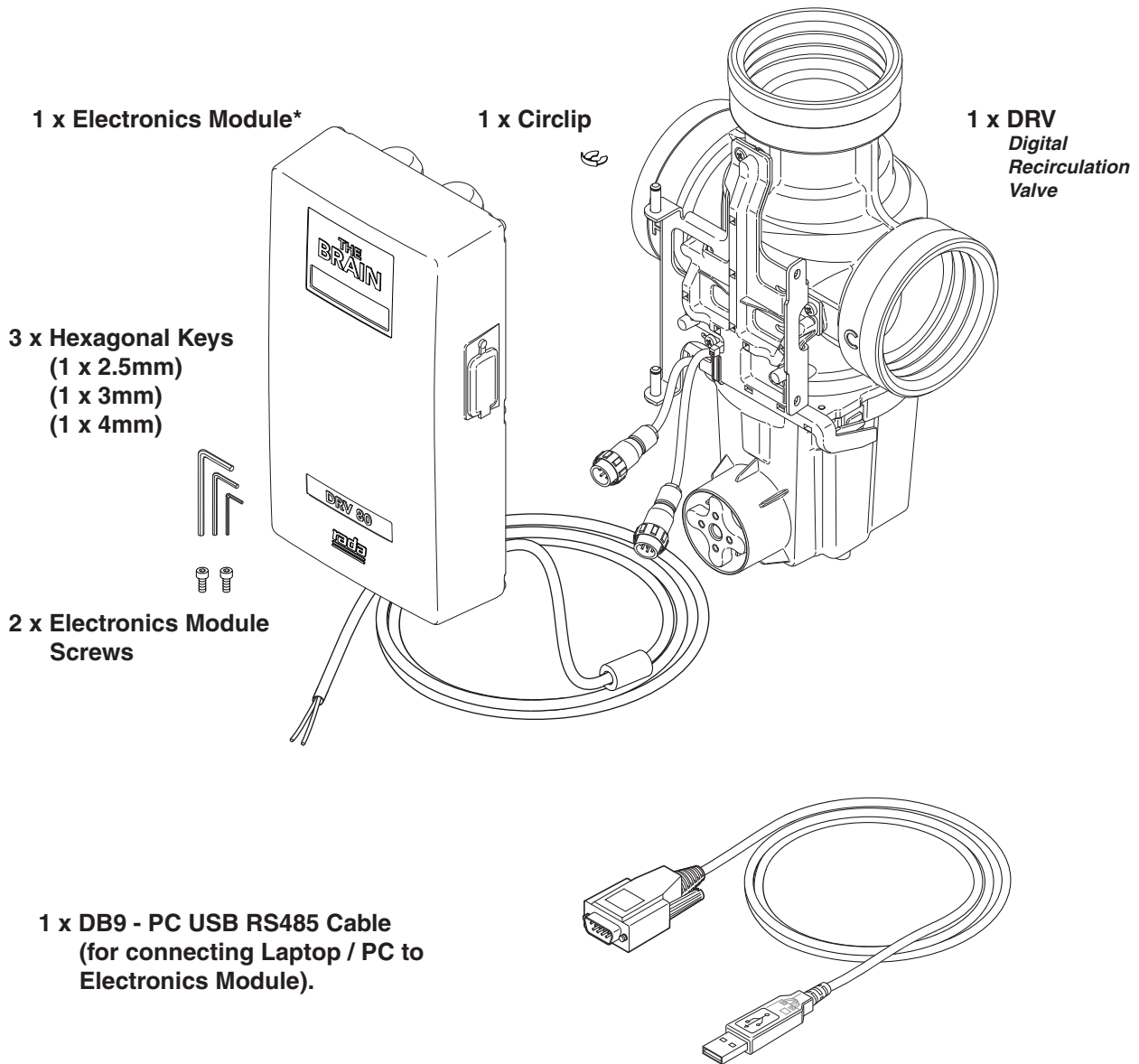

***2 x CR - P2 6V Batteries fitted as supplied.
USB Driver and The Brain® DRV80 Control Software are available to download from website,
www.armstronginternational.com/brain**



Armstrong International
Parc Industriel Des Hants-Sarts, 2ème Avenue No. 4, Haerstal, B-4040, Belgium
armstronginternational.com/brain

DRV80 Dimensions

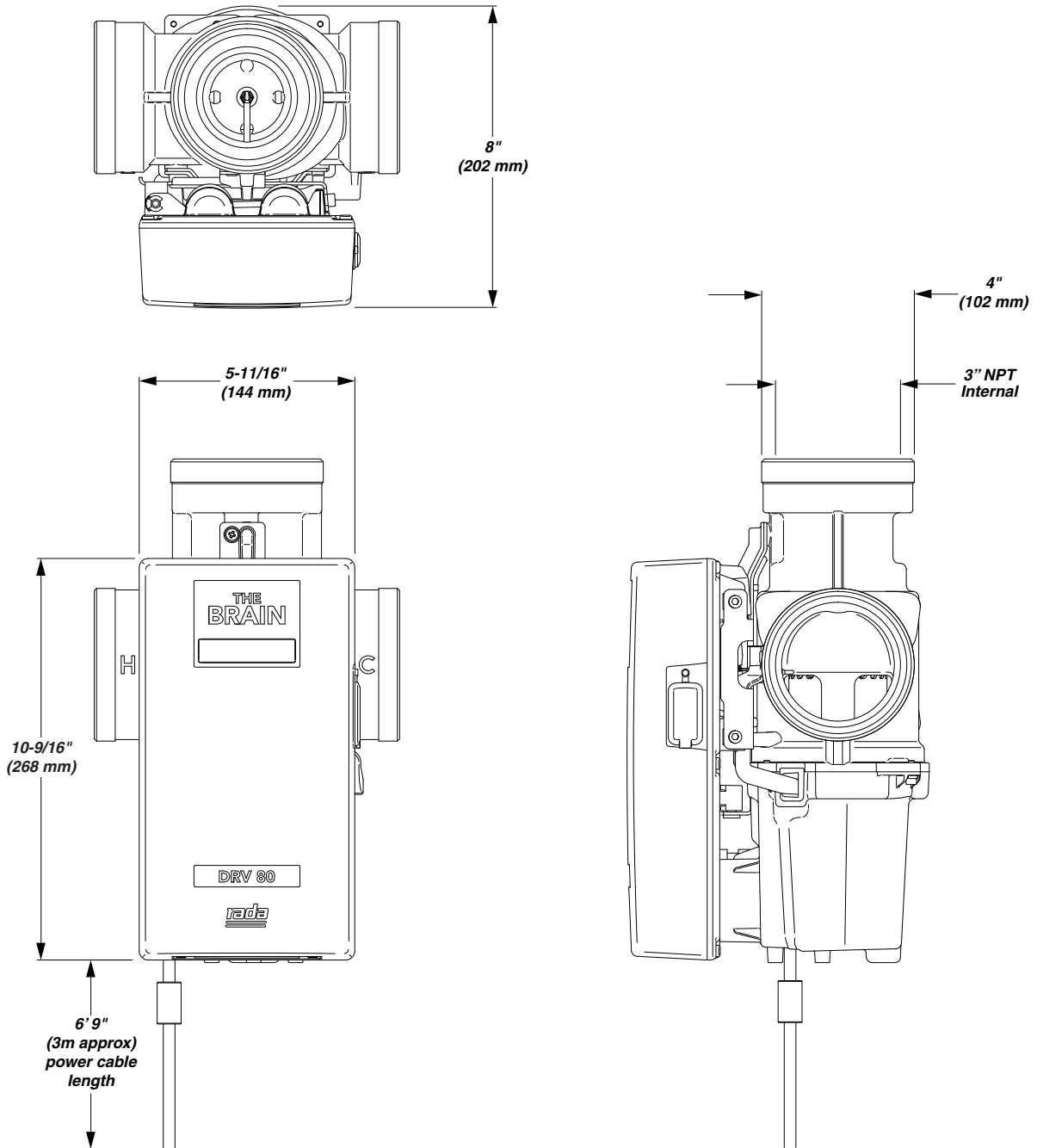

Armstrong International
Parc Industriel Des Hants-Sarts, 2ème Avenue No. 4, Haerstal, B-4040, Belgium
armstronginternational.com/brain

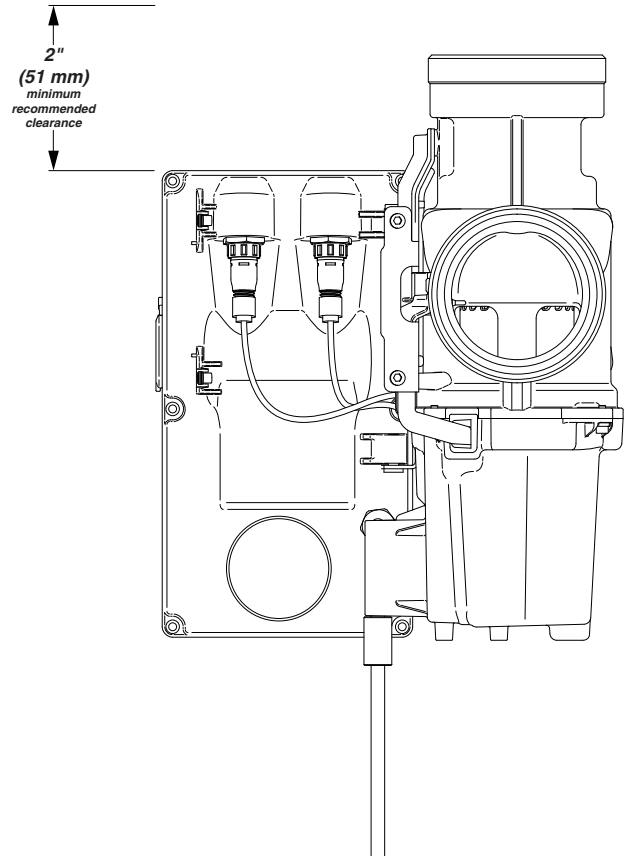
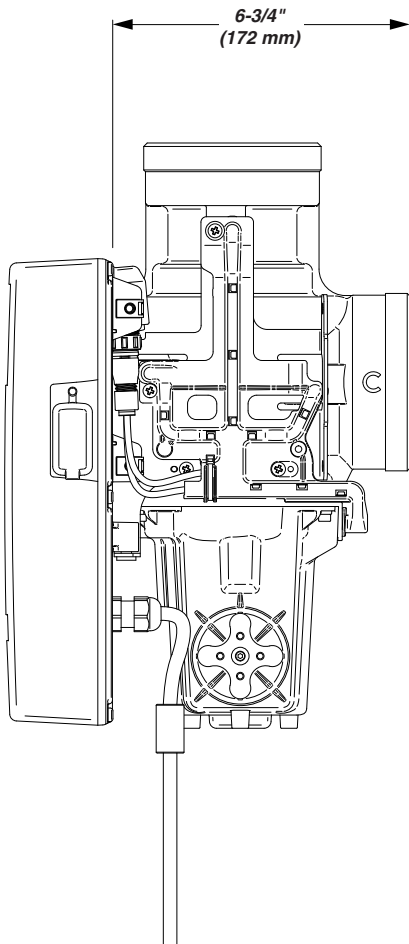
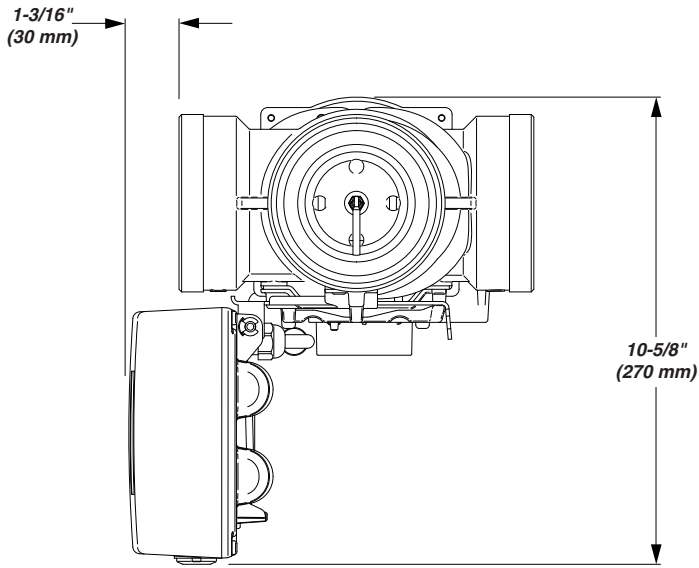

Armstrong International
 Parc Industriel Des Hants-Sarts, 2ème Avenue No. 4, Haerstal, B-4040, Belgium
armstronginternational.com/brain

Specifications

Technical Specifications

General	
Protection	NEMA 3S (IPx4)
Ambient Temperature	minimum ambient temperature of 2 °C maximum 50 °C
Ambient Humidity	95% Non-condensing
Connections	3" NPT Internal (female)
Installation Environment	Suitable for indoor use only
Materials	Electronics Module: PC / ABS DRV: Stainless Steel, engineering plastics and elastomers
Safety	Thermal shutdown upon inlet supply failure and / or power failure
Weight DRV80	10.5 kg
Pressures	
Maximum Inlet Supply Pressure	Static Pressure 1034 kPa (10.3 bar) Dynamic Pressure 862 kPa (8.6 bar)
Supply Pressure Differential	Inlet supply pressures must be nominally equal
Temperatures	
Maximum Inlet Hot Water Supply	85°C
Minimum Inlet Hot Water Supply	2°C above set point
Maximum Inlet Cold Water	25°C
Minimum Inlet Cold Water	2°C
Set Point Range	27 to 70°C
Minimum Recirculation Loop Temperature Loss	1°C
Recirculation Circuit	
Minimum distance to First Outlet	7.6 m
Flow Rates	
Maximum Suggested Flow Rate	625 l/min at 2.3 m/s
Minimum Recirculation Flow Rate	38 l/min
Minimum System Draw-off	0 l/min during recirculation
Electrical	
Power Supply	230V AC ~ 50Hz
Supply Fuse / Circuit Breaker	Switched type 3 Amp
Battery	2 x CR - P2 6V
Duty Cycle	Continuously rated
Auxiliary Relay (see Alerts - Activate Relay on Alert)	
Relay Type	Single pole changeover relay contacts
Power Supply	230V AC / 24V DC
Supply Fuse	2 Amp

Standards and Codes

The Brain® DRV80 conforms to the CE marking requirements.

2004/108/EC	EMC Directive
2006/95/EC	Low Voltage Directive
2011/65/EU	RoHS Directive

EN 61326-1
EN 61000-3-2
EN 61000-3-3
EN 61010-1
EN 50581



Armstrong International
Parc Industriel Des Hants-Sarts, 2ème Avenue No. 4, Haerstal, B-4040, Belgium
armstronginternational.com/brain

Default Settings

DRV80 is preprogrammed to customer requirements prior to shipment

The settings are derived from the **Installation Detail Form (IDF)** filled out by the customer when placing an order.



Armstrong Hot Water Group
221 Armstrong Blvd
Three Rivers, MI 49093
Phone: (269) 279-3602
Fax: (269) 279-3130

**Digital Recirculating Valve (DRV) and Digital Mixing Center (DMC)
Installation Details Form (IDF)**

In order to enter P.O.'s and guarantee delivery dates, a technically accurate and complete IDF is required.

The review and acceptance of the information on the IDF by Armstrong:

1. Approves the order for processing which triggers an e-mail confirmation
2. Indicates that AHWG supports you by endorsing the application
3. Initiates the warranty
4. Delivers a complete, AHWG supported performance guarantee to the final user of the product
5. Drives the relevant point of specification/influence, point of installation and point of order financial allocation if appropriate

Section 1 - Ordering Processing/Tracking Detail:

Point of Order (Sold To): _____ (eg: ABC Mechanical)

City: _____ State: _____ Rep Firm: _____

Point of Installation: _____ (eg: Heinz Ketchup)

City: _____ State: _____ Rep Firm: _____

Point of Specification: _____ (eg: DEF Consulting Engineers)

Other Influence: _____ (eg: Source of Recommendation)

Section 2 – Product Technical Detail:

1. DRV40 DRV50 DRV80	BS
2. Inlet Hot Water Temp: _____ °F	Protocol Options (Select One)
3. Inlet Hot Water Pressure: _____ PSI	LonWorks
4. Inlet Cold Water Temp: _____ °F	Modbus RTU
5. Inlet Cold Water Pressure: _____ PSI	Modbus TCP
6. Maximum Simultaneous Demand: _____ GPM	BACnet Metasys N2
7. Recirculation Pump Flow: _____ GPM	BACnet MSTP
	BACnet IP

Section 3 – Digital Recirculation Valve (DRV) Option Detail:

1. DRV Outlet Water Temperature (OWT): _____ °F	Web Browser Interface
2. BS No Yes	TCP/IP Configuration

Section 4 - Package Reference Information

Reference Drawing # _____ Armstrong Model # _____

List Any Non-Standard Variations:

DRV & DMC IDF Dec 2014

The Installation Detail Form (IDF) is available to download at www.armstronginternational.com/brain or consult factory



Armstrong International
Parc Industriel Des Hants-Sarts, 2ème Avenue No. 4, Haerstal, B-4040, Belgium
armstronginternational.com/brain

Installation

General

Installation must be carried out in accordance with these instructions, and **must** be conducted by designated, qualified and competent personnel.

The installation **must** comply with all relevant national and local water plumbing regulations.

The installation **must** comply with all relevant national and local electrical wiring regulations.

The DRV80 **must** be installed per the piping diagrams (pages 12 - 15). All plumbing components are to be supplied by the installer. Failure to include these components will compromise the DRV and system performance.



Warning! The DRV80 **must** be EARTHED.

The DRV80 is intended to be permanently connected to the fixed electrical wiring. A means for electrical isolation of the DRV80 shall be provided, this device **must** be suitably located, easily reached and identified as to its purpose.



Caution! The DRV80 **must** be installed in a dry area where it will not be able to freeze (minimum ambient temperature of 2 °C).

Notes:

1. DRV80 is supplied fully performance and pressure tested.
2. The DRV80 **must** be installed in an area where it is accessible to do any maintenance tasks e.g. connecting Laptop / PC, removal of the cover, replacing worn parts etc.
3. Suitable connections for ease of maintenance should be used on the inlet and outlet ports. (*Isolation valves and unions.*)
4. The hot and cold water inlet supply pressures must be nominally equal.
5. The cold inlet supply feed to the DRV80 must be “tapped” directly from the cold inlet supply to the water heater.
6. The inlet supply pipework **must** be thoroughly flushed before fitting the DRV80.

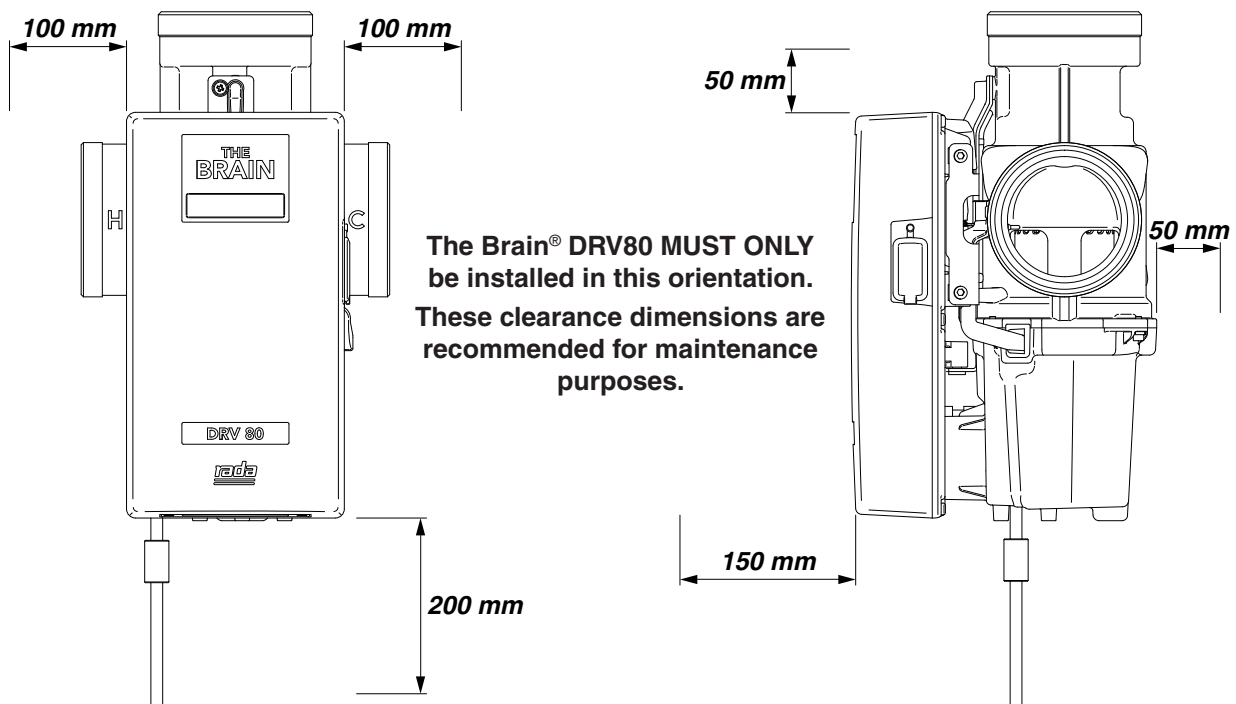

Installation Requirements

- 1** Inlet isolating valves (full flow type) must be installed close to the DRV80 for ease of maintenance. It is recommended that outlet isolating valves (full flow type) are also installed.
- 2** The use of supply / return strainers will reduce debris entering the DRV80. The recommended gauge for such strainers is 35 mesh (mesh aperture dimension 0.5mm).
- 3** Inlet pressure tapings which allow measurement of the inlet pressures to the DRV80 under operating conditions are particularly recommended for in-service testing.
- 4** Pipework must be rigidly supported to avoid any strain on the connections.
- 5** Make sure the pipe layout will avoid the build up of trapped air in the system. Air release valves can be used where this is not possible.
- 6** Inlet and outlet threaded joint connections should be made with PTFE thread sealing tape or liquid sealant. Do not use oil-based, non-setting joint compounds.
- 7** To eliminate pipe debris it is essential that supply pipes are thoroughly flushed before connection to the DRV80.



Piping Diagrams

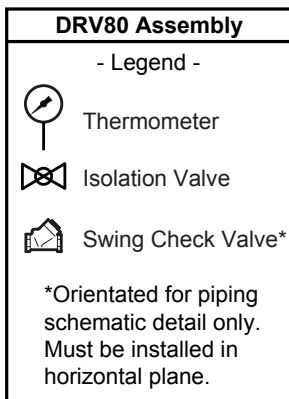
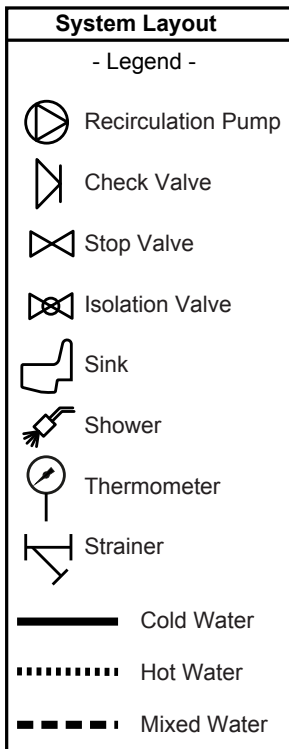

Items are installer supplied

Figure 12-1. Single Valve Installation

Note: For 0-90 GPM (0-340 l/min) Systems the DRV80 inlet connections are 2"

Note: For 0-150 GPM (0-567 l/min) Systems the DRV80 inlet connections are 3"

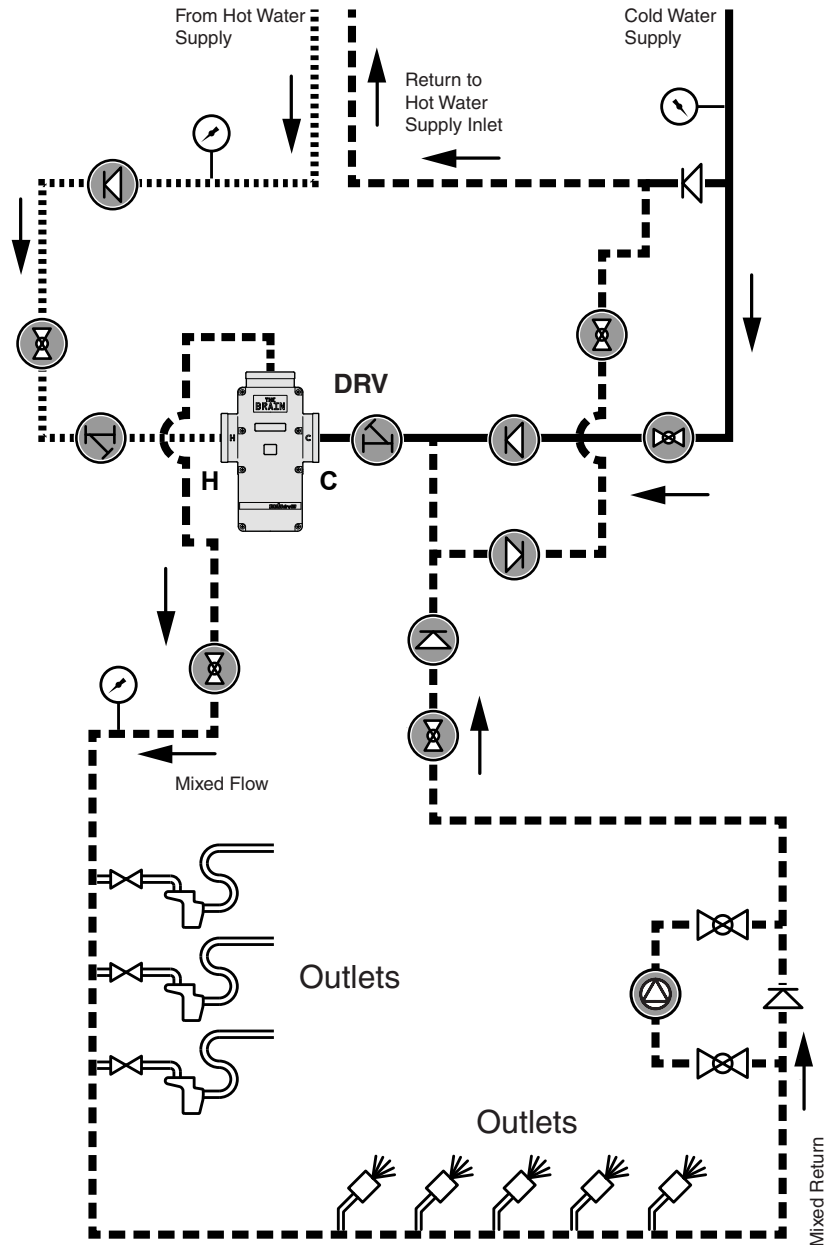

Armstrong International
 Parc Industriel Des Hants-Sarts, 2ème Avenue No. 4, Haerstal, B-4040, Belgium
armstronginternational.com/brain

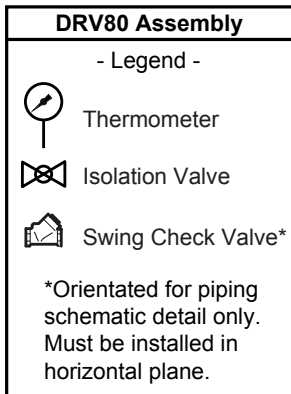
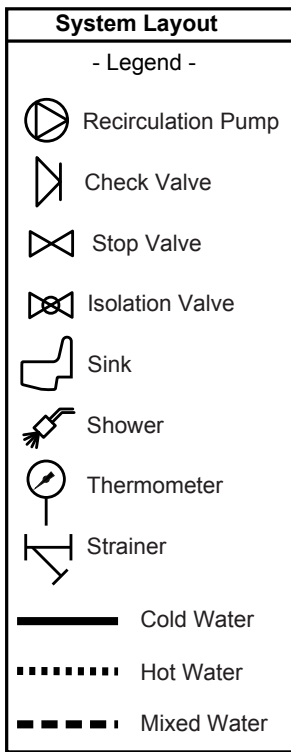

 Items are installer supplied

Figure 13-1. Dual Valve 300 GPM (1135 l/min) Installation

Note: DRV80 inlet connections are 3".



Armstrong International
 Parc Industriel Des Hants-Sarts, 2ème Avenue No. 4, Haerstal, B-4040, Belgium
armstronginternational.com/brain

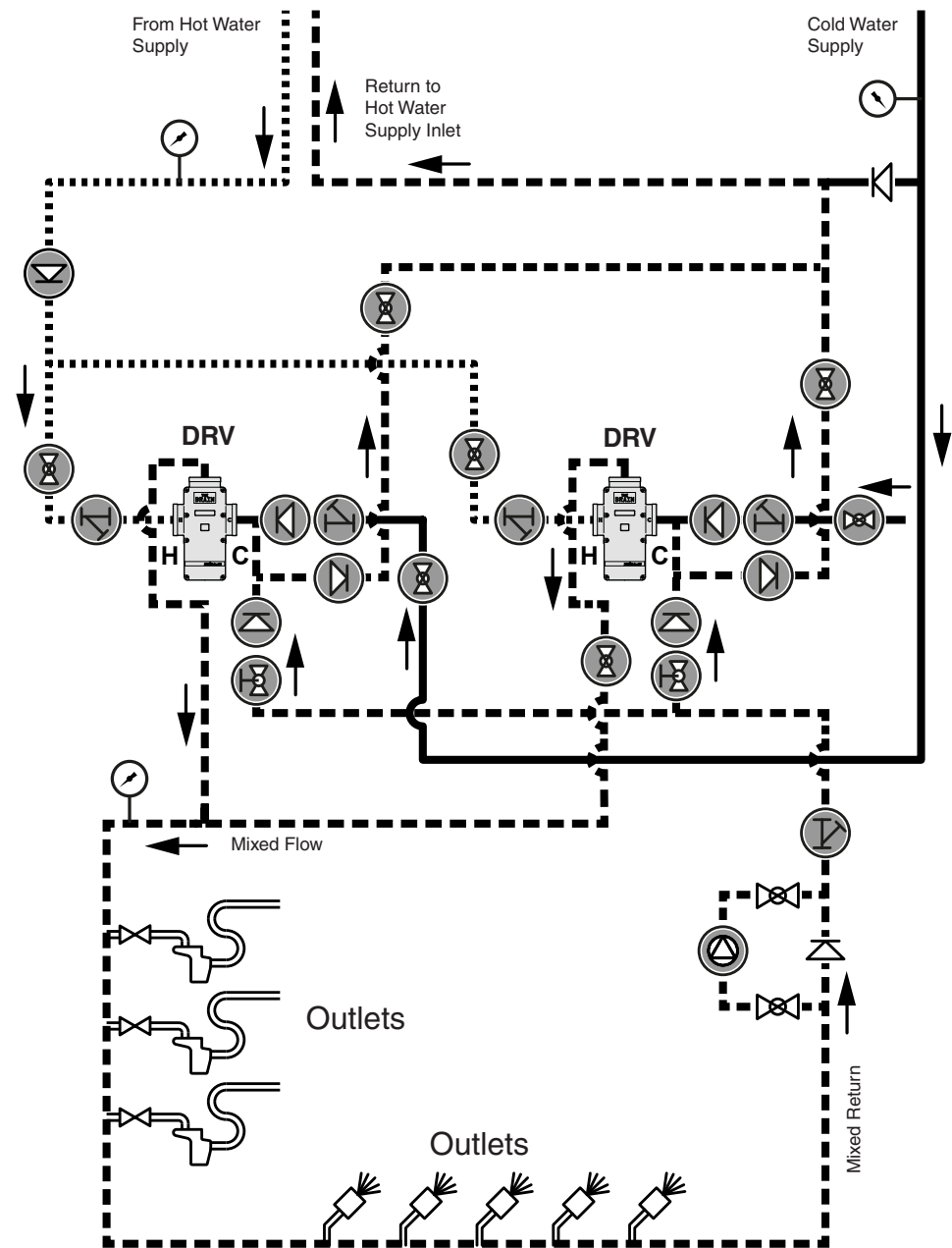
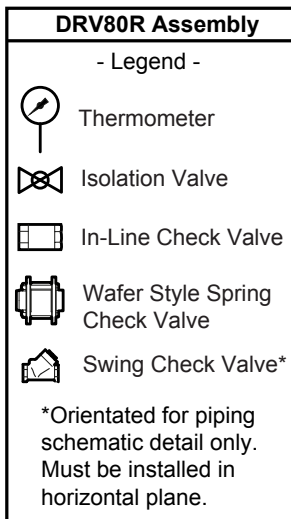
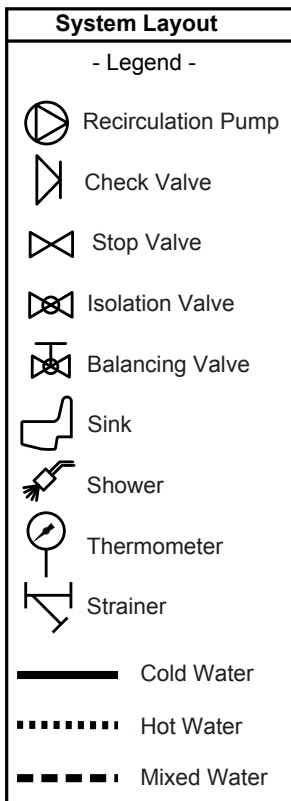

 Items are installer supplied

Figure 14-1. Single Valve Installation

Note: For 0-90 GPM (0-340 l/min) Systems the DRV80R inlet connections are 2"

Note: For 0-150 GPM (0-567 l/min) Systems the DRV80R inlet connections are 3"

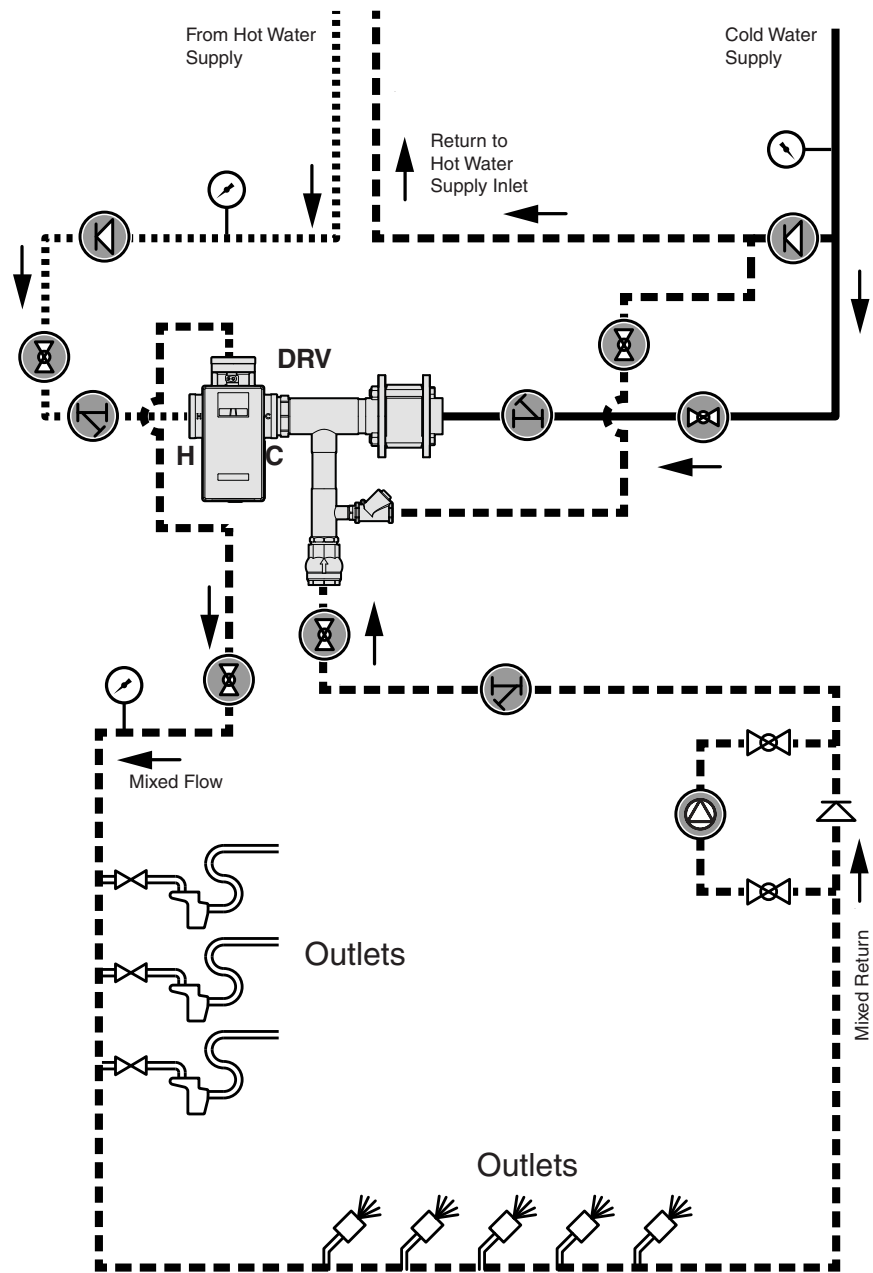

Armstrong International
 Parc Industriel Des Hants-Sarts, 2ème Avenue No. 4, Haerstal, B-4040, Belgium
armstronginternational.com/brain

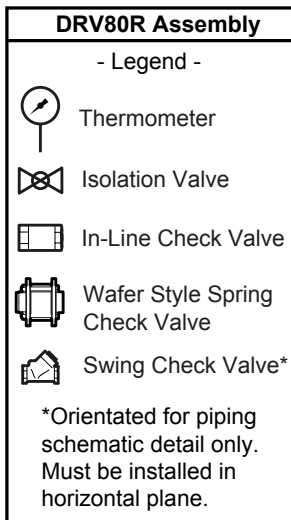
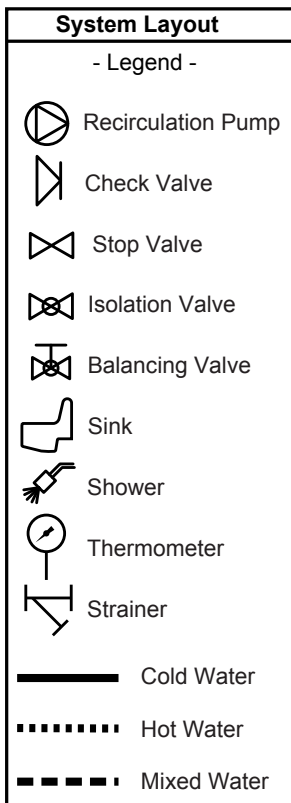

Items are installer supplied

Figure 15-1. Dual Valve 300 GPM (1135 l/min) Installation

Note: DRV80R inlet connections are 3".

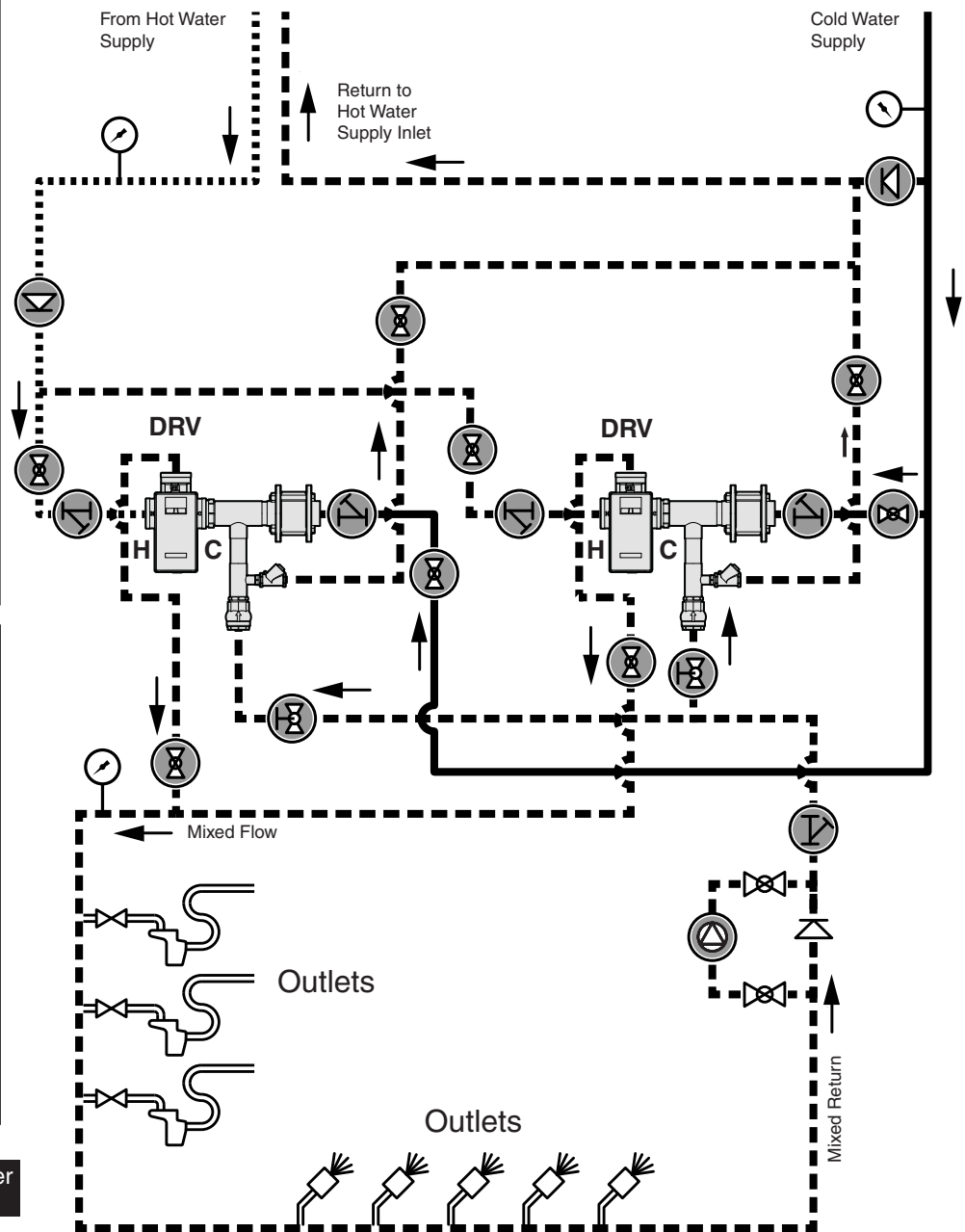

Armstrong International
 Parc Industriel Des Hants-Sarts, 2ème Avenue No. 4, Haerstal, B-4040, Belgium
armstronginternational.com/brain

Installation - DRV80

- 1 Before fitting to the pipework, it is recommended that connectors are fitted to the inlets and outlet. This will enable the DRV to be easily removed, if required.
- 2 Flush pipework thoroughly (minimum of 5 minutes).
- 3 Fit the DRV to the pipework.

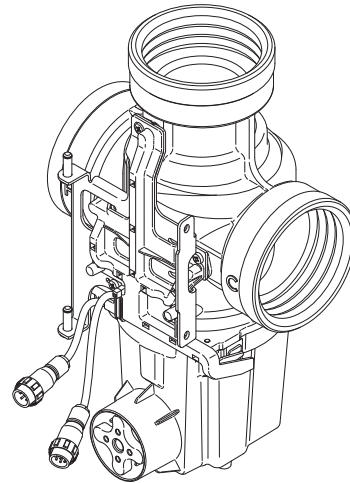

- 4 Attach the Electronics Module and secure using the circlip supplied.

Hole markers inside the Electronics Module case indicate where cables can be fitted for options such as **BrainScan®** or an **error relay**. If these are required but have not been prefitted, contact Armstrong for further advice.

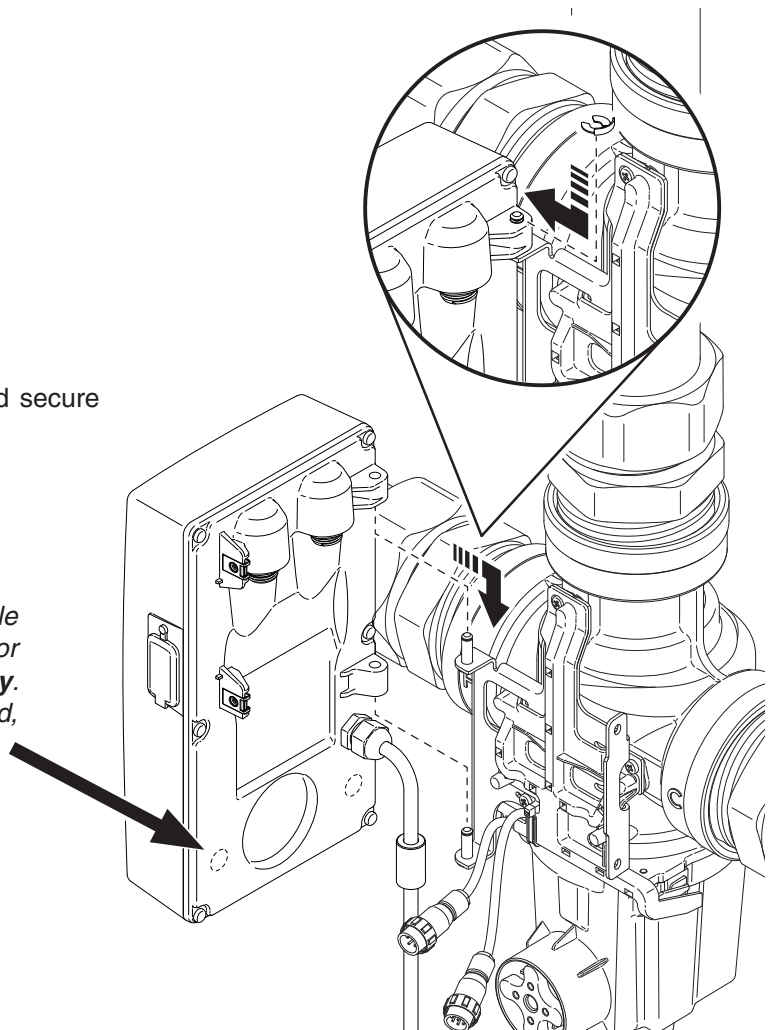

Armstrong International
Parc Industriel Des Hants-Sarts, 2ème Avenue No. 4, Haerstal, B-4040, Belgium
armstronginternational.com/brain

- 5 Connect and secure the 8 pin plug to the back of the Electronics Module.

Important! Do not fit the 4 pin plug at this stage. To prevent a back EMF the system must be flooded with water before the 4 pin plug is fitted.

- 6 Connect the power cable to the primary power supply via switched circuit breaker with a 3 Amp fuse.

A separate, permanently connected supply **must** be taken from the ring main to the appliance through a 3 Amp double pole switched fuse spur providing a minimum of 3 mm contact separation gap in each pole. This disconnection device should be located near to the DRV80 and identified to its purpose.

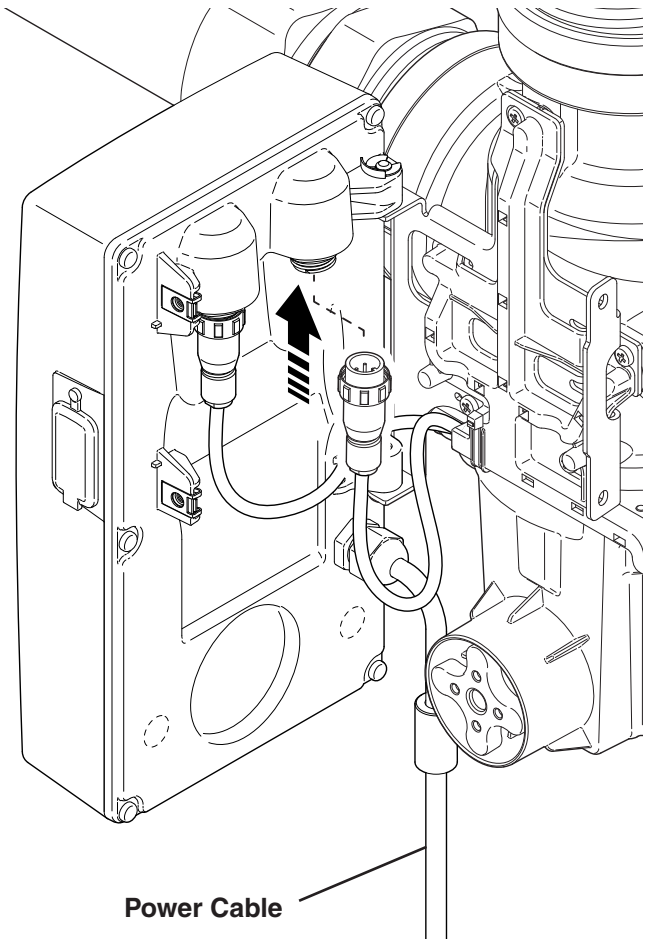

- 7 Commission the DRV80 and recirculation system using the following instructions...



Armstrong International
Parc Industriel Des Hants-Sarts, 2ème Avenue No. 4, Haerstal, B-4040, Belgium
armstronginternational.com/brain

Commissioning

Commissioning must be carried out in accordance with these instructions by designated, qualified and competent personnel.

- 1 Ensure the system is powered off and the 4 pin plug is unplugged on the electronics module.
- 2 Flood the system in the following sequence:
 - Open the cold water supply isolation valve(s).
 - Open the outlet flow isolation valve(s).
 - Open the hot water supply isolation valve(s).
 - Once flooded, connect and secure the 4 pin plug to the electronics module.

- 3 Close and secure the Electronics Module with the 2 x 4mm hexagon socket screws provided.
Note! The Electronics Module must be closed for the DRV80 to function.

- 4 Ensure that the system is powered and the display on the Electronics Module is illuminated.
- 5 Make sure the hot and cold inlet supplies are at their designated pressures and temperatures.
- 6 Close all the mixed water outlets and turn on the circulating pump.

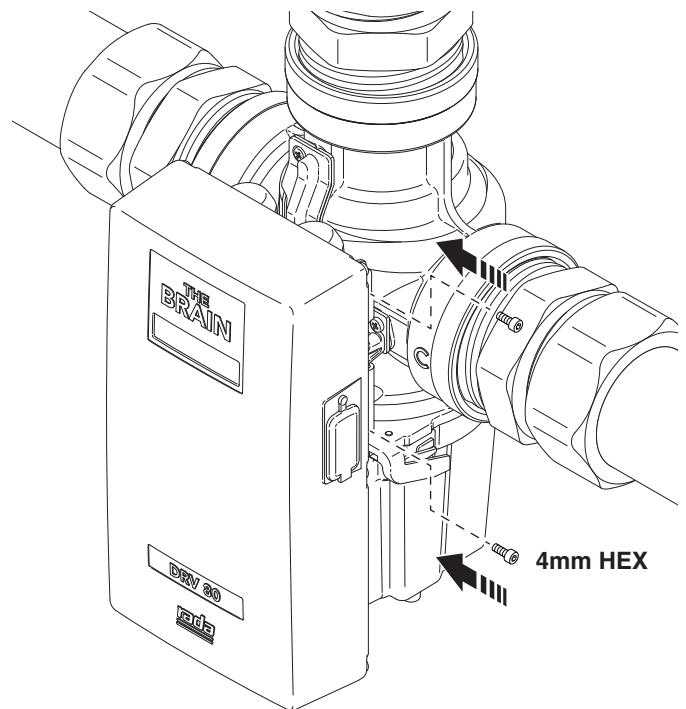

Armstrong International
Parc Industriel Des Hants-Sarts, 2ème Avenue No. 4, Haerstal, B-4040, Belgium
armstronginternational.com/brain

7

The LCD display will indicate the outlet water temperature and the outlet water temperature setpoint. The setpoint was preprogrammed at the factory according to the installation details specified on the **Installation Detail Form (IDF)**.

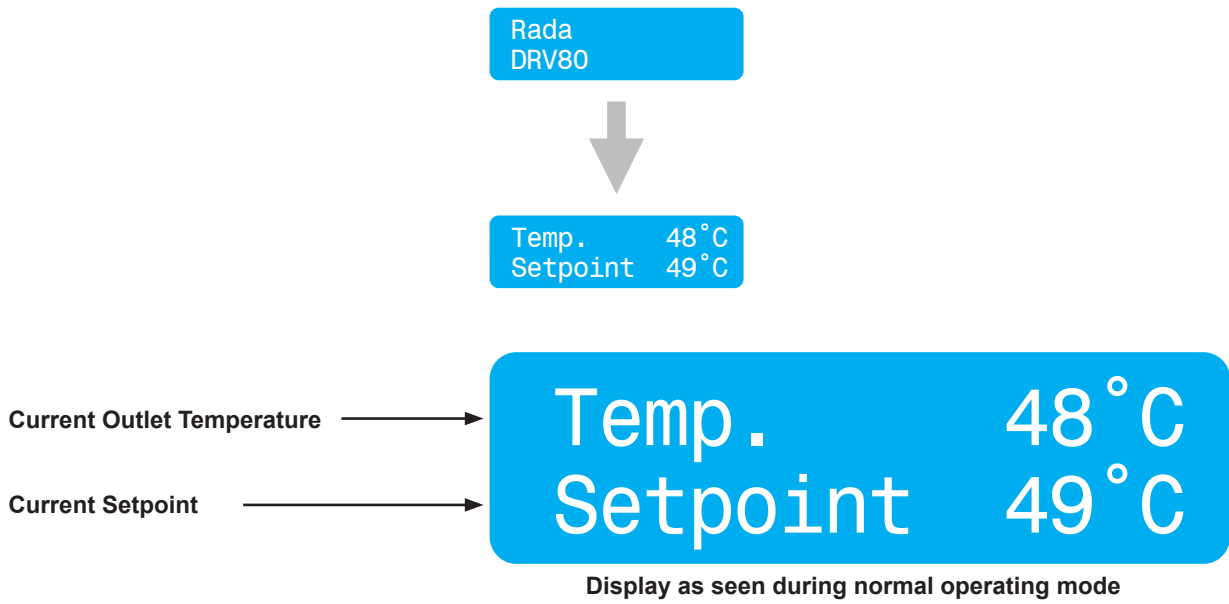

Operation

Temperature Adjust Using Laptop or PC

- 1 Operating System: Microsoft Windows XP, Vista or Windows 7, Windows 8 - 8.1 and Windows 10.
Minimum Screen Resolution: 1024 x 768 (Recommended 1280 x 1024 or higher.)
- 2 Download and install:

USB Driver - www.ftdichip.com/Drivers/VCP.htm

The Brain(R) DRV Programming Software - www.armstronginternational.com/brain
- 3 Connect the Laptop / PC to the Electronics Module with PC USB Cable supplied.
- 4 Connect the cable to the serial port on the Electronics Module and the Laptop / PC.
- 5 Run the DRV80 Control Software by double clicking the icon on the desktop or search for and run the file **Brain DRV Programming Software.exe**

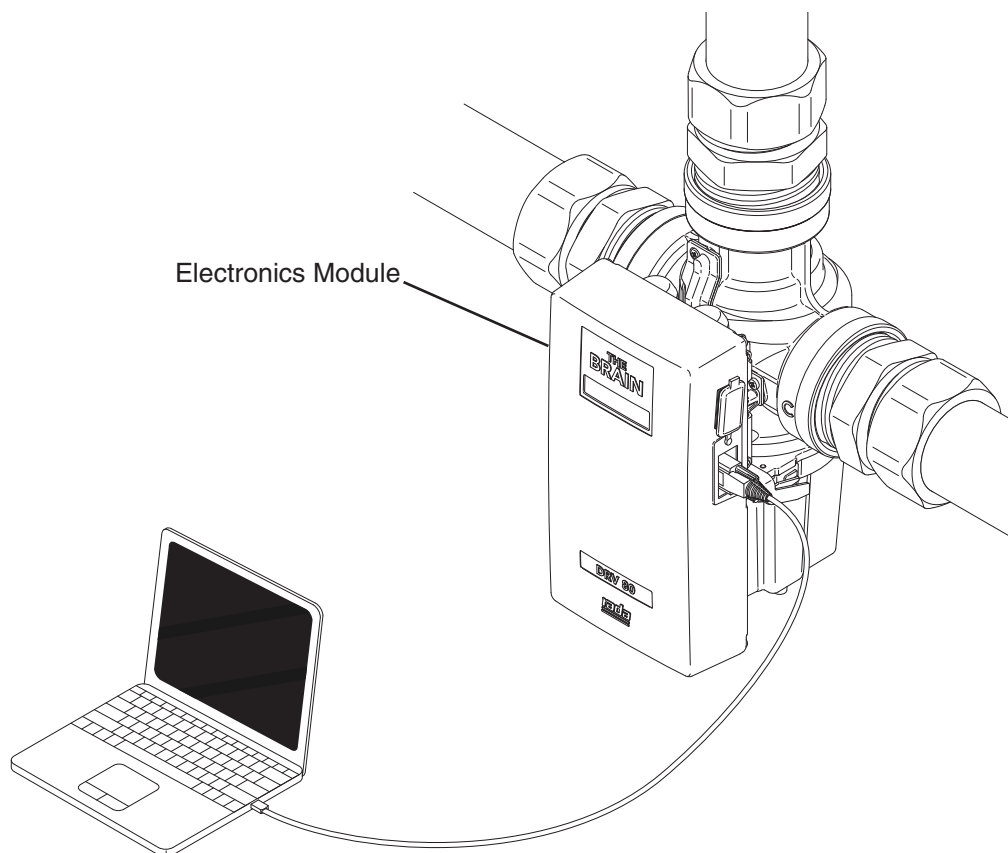

Armstrong International
Parc Industriel Des Hants-Sarts, 2ème Avenue No. 4, Haerstal, B-4040, Belgium
armstronginternational.com/brain

Control Software

Introduction

The Brain® DRV80 control software has been designed to control all aspects of the DRV function.



Check the DRV80 is connected to the PC / Laptop device. Double click **The Brain® DRV Programming Software** icon on the desktop or search for and run the file **Brain DRV Programming Software.exe**.

There are three options for adjusting the DRV80 settings:

1. A Microsoft Windows based Laptop / PC Computer with **The Brain® DRV Programming Software** and a USB Cable.
2. A Web Browser via the integral serial port and **BrainScan®** supplied by Armstrong.*
3. A Building Automation System (BAS).

** This option is detailed in a separate Installation, Operation and Maintenance (IOM) Guide for **BrainScan®**. Available by contacting Armstrong technical support.*



Armstrong International
Parc Industriel Des Hants-Sarts, 2ème Avenue No. 4, Haerstal, B-4040, Belgium
armstronginternational.com/brain

COM Port

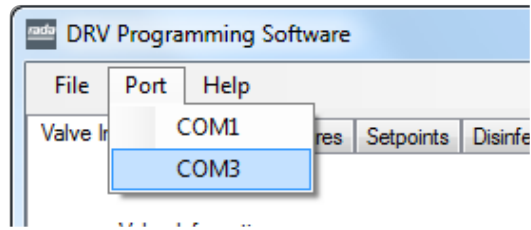

Locate the DRV80 by selecting the correct **COM Port**. The COM Port can be confirmed using the **Device Manager** utility within the Microsoft Windows OS.

Note! Make sure the USB Driver has been installed.

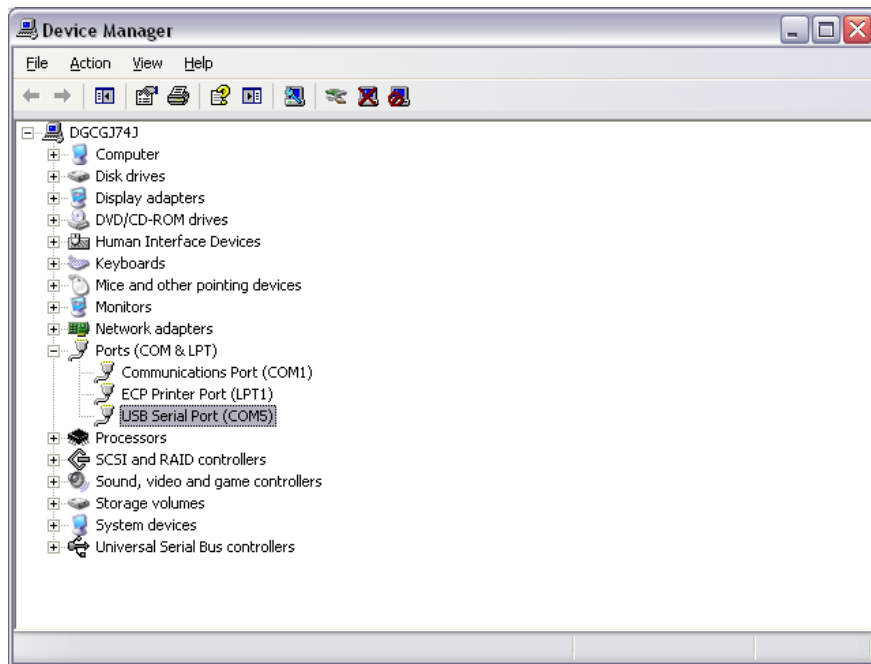

Example of Microsoft Windows XP Device Manager



Armstrong International
Parc Industriel Des Hants-Sarts, 2ème Avenue No. 4, Haerstal, B-4040, Belgium
armstronginternational.com/brain

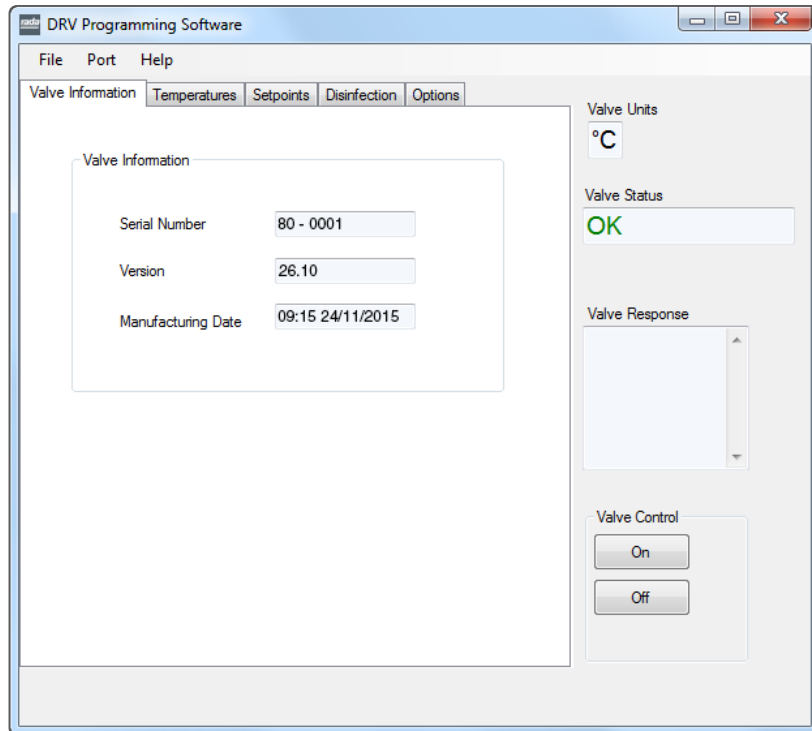

The DRV80 is now connected to the PC / Laptop device and will receive data automatically.

The control screens can be selected individually by clicking on each of the tabs.

The general status of the DRV80 is displayed on the right of the screen.

Valve Units - displays the temperature units.

Valve Status - displays the DRV80's current operating status.

Valve Response - displays any confirmation of commands received or any error messages.

Valve Control - Alters the DRV80's state **ON / OFF**. This is required when making specific adjustments to the DRV80's settings (*detailed further in these instructions*).



Armstrong International
 Parc Industriel Des Hants-Sarts, 2ème Avenue No. 4, Haerstal, B-4040, Belgium
armstronginternational.com/brain

DRV Information

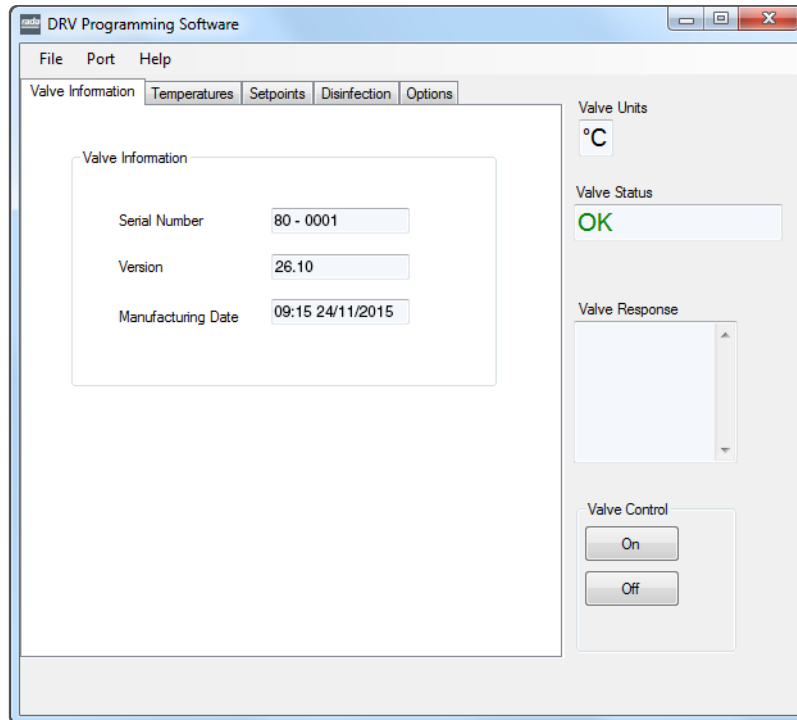

Once the DRV80 is connected, the DRV information screen is updated.

Serial Number - The serial number of the DRV80 assigned at manufacture.

Version - The version of the DRV80 Control Software.

Manufacturing Date - The date the DRV80 was built.

These data fields are read only and can only be changed by updating the DRV80 internal software (*only to be performed by a qualified service engineer*).



Armstrong International
Parc Industriel Des Hants-Sarts, 2ème Avenue No. 4, Haerstal, B-4040, Belgium
armstronginternational.com/brain

Temperatures

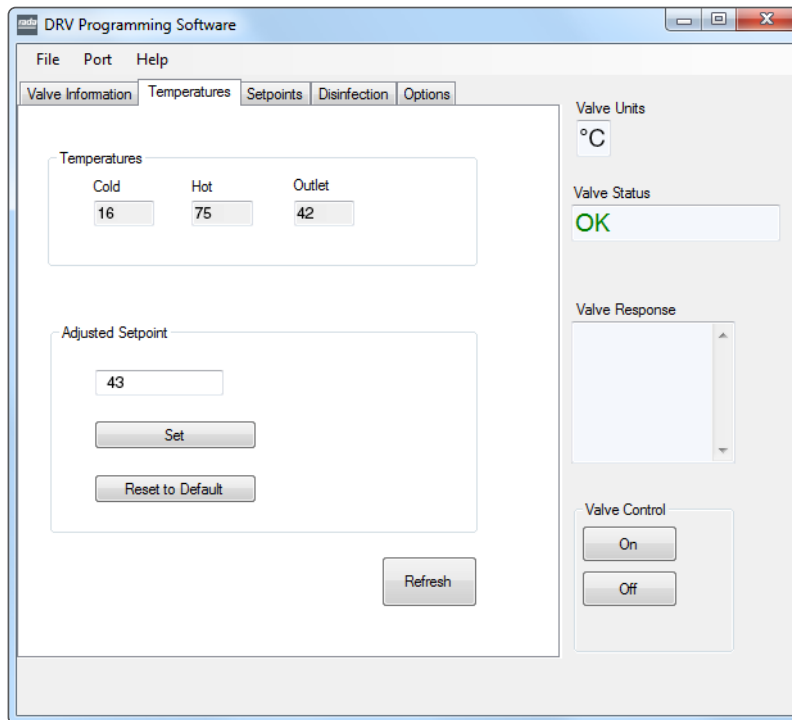

Temperatures

The **Cold, Hot and Outlet** are read only values and can be used to monitor the current settings. They are continuously updated every **2 seconds**.

Adjusted Setpoint

- 1 Input **Adjusted Setpoint** value
- 2 Click **Set** to transfer the value to the DRV80
- 3 Change the **Adjusted Setpoint** back to the default value by clicking **Reset to Default**.

The **Adjusted Setpoint** value is displayed on the DRV80 as **Setpoint**.

Temp	42 °C
Setpoint	43 °C



Armstrong International
Parc Industriel Des Hants-Sarts, 2ème Avenue No. 4, Haerstal, B-4040, Belgium
armstronginternational.com/brain

Setpoints *(Also see **Setpoints - Explained** page 28)*

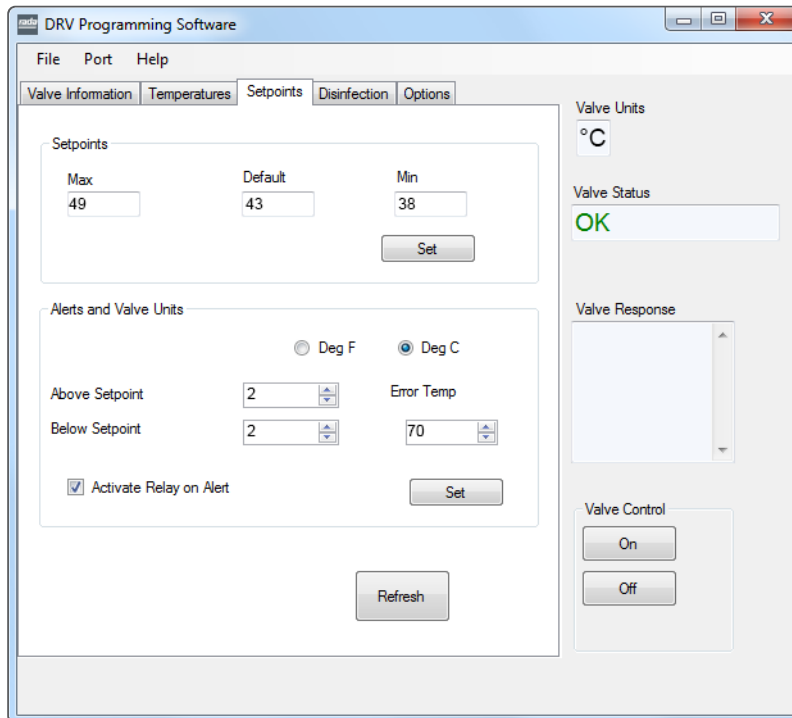

Setpoints

*(Also see **Setpoints - Explained**)*

Alter the **Max**, **Min** and **Default** values as required for the application.

- 1 Switch **Valve Control** to **OFF**.
- 2 Click **Set** to transfer the values to the DRV80.
- 3 Switch **Valve Control** back **ON**.
- 4 The **Setpoint Default** value is displayed on the DRV80.

Units

- 1 Click the preferred **Valve Units** (**°F** or **°C**).
- 2 Switch **Valve Control** to **OFF**.
- 3 Click **Set** to transfer the value to the DRV80.
- 4 Switch **Valve Control** back **ON**.



Armstrong International
Parc Industriel Des Hants-Sarts, 2ème Avenue No. 4, Haerstal, B-4040, Belgium
armstronginternational.com/brain

Alerts - optional

(Also see **Alerts - Explained** page 29 and **Preset Display Alerts** page 31)

- 1 Input the **Above Setpoint and Below Setpoint** values.
- 2 Input the **Error Temp** value.
- 3 Click **Activate Relay on Alerts** if required.
- 4 Switch **Valve Control** to **OFF**.
- 5 Click **Set** to transfer the values to the DRV80.
- 6 Click **Refresh** to force display and confirm the updated values.
- 7 Switch **Valve Control** back **ON**.



Armstrong International
Parc Industriel Des Hants-Sarts, 2ème Avenue No. 4, Haerstal, B-4040, Belgium
armstronginternational.com/brain

Setpoints - Explained

The setpoint is the required outlet water temperature. The values in the **Setpoints** tab control the range in which the setpoint can be adjusted to, but not the current setpoint itself. The **Default** value is the temperature the DRV will return to should the power be lost and the DRV80 is reset. The **Default** is adjustable, but cannot be more than the **Max.** (maximum) value or less than the **Min.** (minimum) value.

Example 1

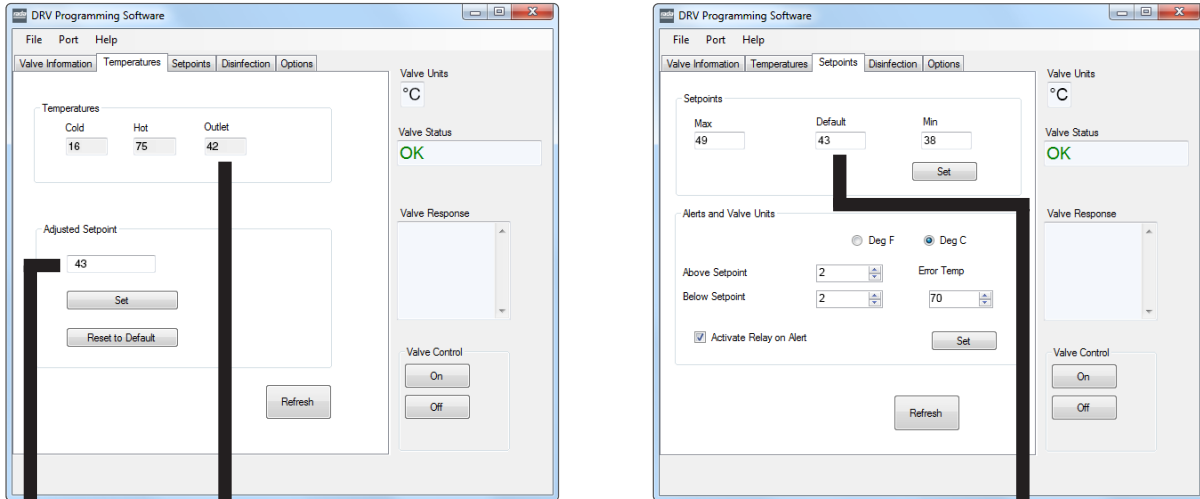

Temp 42°C
Setpoint 43°C

normal operation

Temp 42°C
Setpoint 39°C

*reset after power failure
(to change back to 43°C use Adjusted Setpoint)*



Alerts - Explained

DRV80 will issue an alert which is activated upon a breach of pre-established **above setpoint** and **below setpoint** values (factory default +2 °C, -2 °C) located under the **Setpoints** tab. Upon activation, the display on the DRV80 will read **Temp High** or **Temp Low**. **This advisory feature cannot be disabled.**

If the **Activate Relay on Alert** box is checked, this will enable a feature which can be used to activate an auxiliary alarm or solenoid valve. A connection is made to a set of single pole changeover relay contacts fused at 2 Amps (see **Specifications**). When the DRV80 is operating normally, C terminal and NO terminal of the relay have continuity. During the following circumstances, the C terminal and NC terminal have continuity:

1. Power failure.
2. Start up sequence.
3. Outlet temperature causing an alert signal
(can be disabled via the **Setpoints** tab of **The Brain DRV Programming Software**)
4. Outlet temperature causing an error signal.
5. Internal fault on PCB.
6. Battery failure.
7. Thermistor failure.

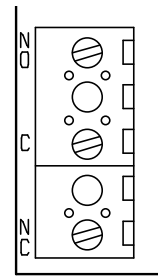

Relay
(PCB, see page 47)

DRV80 will also issue an alert if the preset **Error Temp** value located under the **Setpoints** tab is exceeded (factory default 70 °C). In the event of an Error Temp, the display on the DRV80 will read **Error Temp**, the aforementioned relay will be activated and the DRV80 will assume a position where no hot water can enter the DRV through the hot water inlet. **This safety feature cannot be disabled.**

The **Alert** and the **Error Temp** activation can be relayed to a Building Automation System (BAS), a Local Area Network (LAN) or can be accessed online via the integrated **Modbus** and **BrainScan®** connection port if connected and programmed accordingly.



Armstrong International
Parc Industriel Des Hants-Sarts, 2ème Avenue No. 4, Haerstal, B-4040, Belgium
armstronginternational.com/brain

Example 2

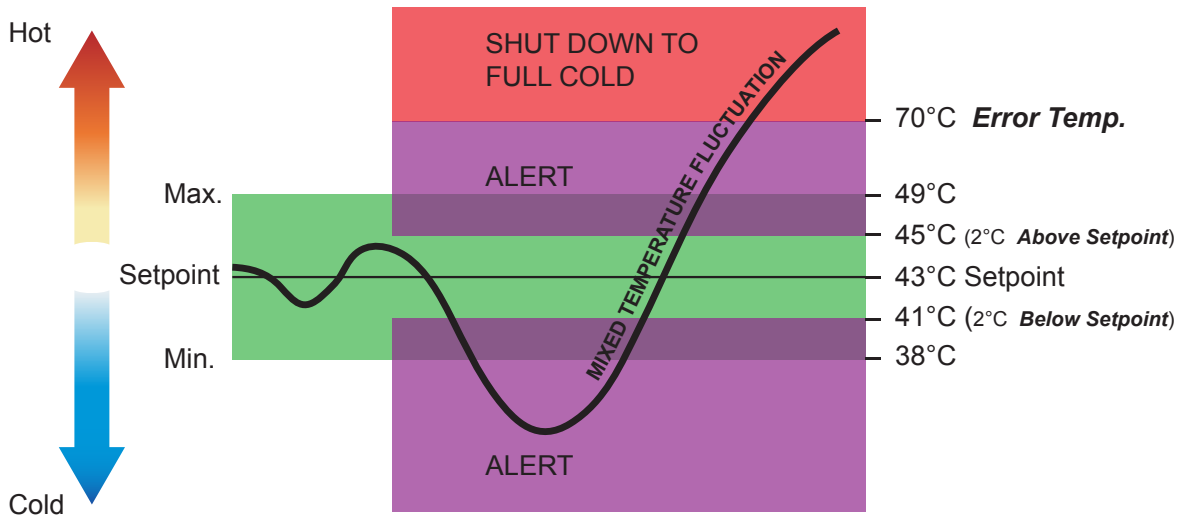
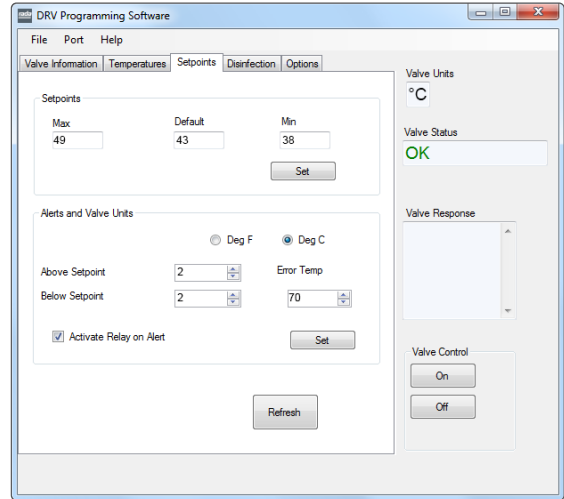
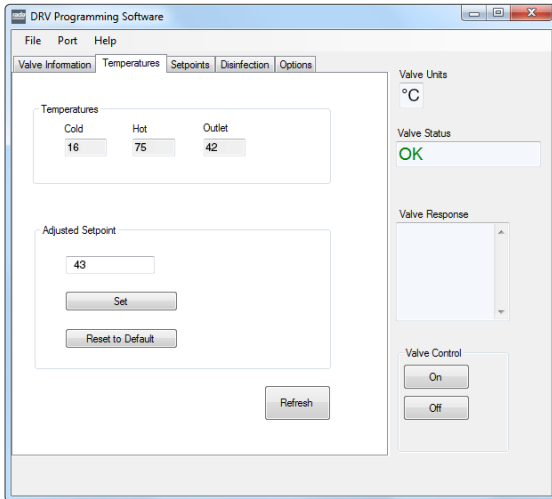

Important!

The **Error Temp** value cannot be set lower than the **Max** value plus the **Above Setpoint** value.

Note! **Adjusted Setpoint** value does not need to be the same as the **Default** value. Both **Adjusted Setpoint** and **Default** can be set within the **Max** and **Min** range only.



Armstrong International
 Parc Industriel Des Hants-Sarts, 2ème Avenue No. 4, Haerstal, B-4040, Belgium
armstronginternational.com/brain

Preset Display Alerts

The DRV80 is supplied preprogrammed to the customers requirements specified on the **Installation Detail Form (IDF)**. In addition, Armstrong has preset two DRV80 display alerts:

Level 1 - Alert preset: 2°C **Above Setpoint** DRV80 will display **Temp High**
 preset: 2°C **Below Setpoint** DRV80 will display **Temp Low**

Level 2 - Error preset: 6°C above specified setpoint DRV80 will display **Error Temp and switch to full cold**

Example 3

If the Adjusted Setpoint were set at 43°C, the alerts would operate in the following way...

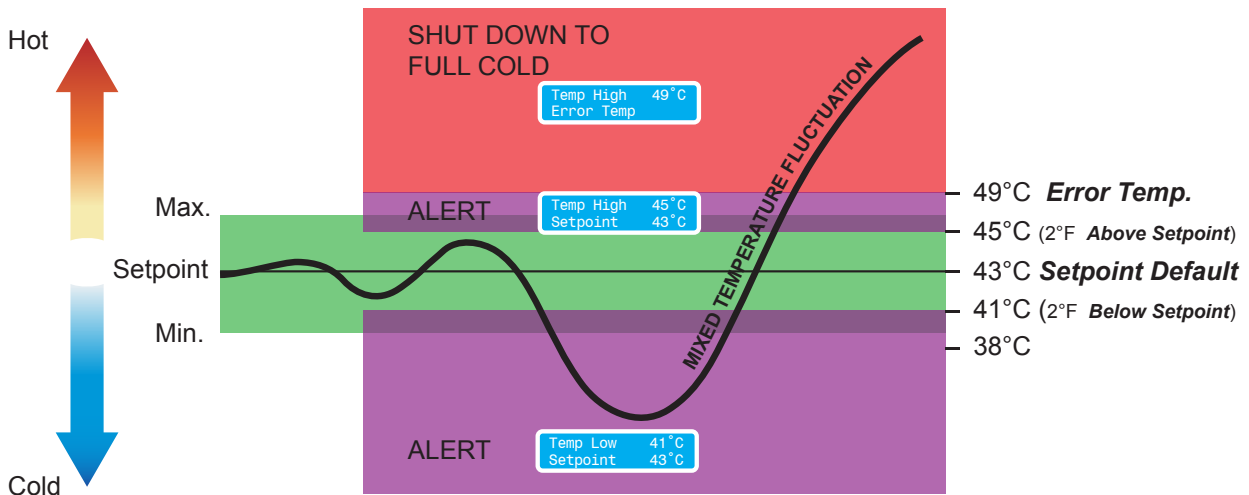

Temp High 49°C
Error Temp

Important!

Error Temp can also indicate the need for maintenance. (See **DRV80 Display Errors** for further details.)



Disinfection

Thermal Disinfection

IMPORTANT! PLEASE READ CAREFULLY

The thermal disinfection mode of the DRV80 is *not* an automated process. It is manually activated by the supervisor to increase the temperature of the blend circuit to equal the temperature of the hot supply. The circuit pipework and outlets can be thermally disinfected as part of a bacterial infection control regimen.

DO NOT USE THE THERMAL DISINFECTION FEATURE IF THE HOT WATER SUPPLY CAN EXCEED 185°F (85°C)!

THE MAXIMUM TEMPERATURE FOR DISINFECTION SETPOINT MUST BE 185°F (85°C).



Warning! Thermal disinfection is a potentially hazardous process to raise the water temperature to a level that will scald or even kill. It is therefore the responsibility of the person supervising the process to make sure it is carried out correctly and safely.

ALL DRV80 DISPLAY ALERTS AND ERRORS ARE DISABLED DURING THE PROCESS!

It is the responsibility of the supervisor to make sure that:

1. An appropriate Risk Assessment is carried out in accordance with the local or national regulations.
2. The water temperature is raised to and held at the required level at all parts of the circuit for the required duration as stated in the Risk Assessment.
3. All outlets are flushed for the correct amount of time if required by the Risk Assessment.
4. Appropriate measures are taken to make sure that none of the outlets are used while the water is at an unsafe temperature.
5. Once thermal disinfection is complete, the supervisor should return the DRV80 to its normal operating mode using the **Cool Down** button within the **Disinfection screen**. This will switch the DRV80 to its full cold position and allow the blend circuit to be reduced gradually to a safe temperature level*. Make sure the blend circuit temperature returns to normal operation within the **Disinfection Timeout** period (see page 35).
6. The Disinfection cycle is monitored constantly and the supervisor is able to stop the cycle using the **Abort** button in the **Disinfection** screen.

Without a draw off, the water in the blend circuit will remain hot for a long time. In order to speed up the temperature reduction, a draw-off must be made during **Cool Down using the last outlet of the blend circuit, or a dump valve fitted near to the end of the blend circuit. Check with local water authorities with regard to water temperature limitations to drain.*

*Failure to complete a sufficient cool down of the blend circuit may result in a **Temp High** alert or an **Error Temp shut down to full cold** (see **Alerts** on pages 29 - 31).*



Armstrong International
Parc Industriel Des Hants-Sarts, 2ème Avenue No. 4, Haerstal, B-4040, Belgium
armstronginternational.com/brain

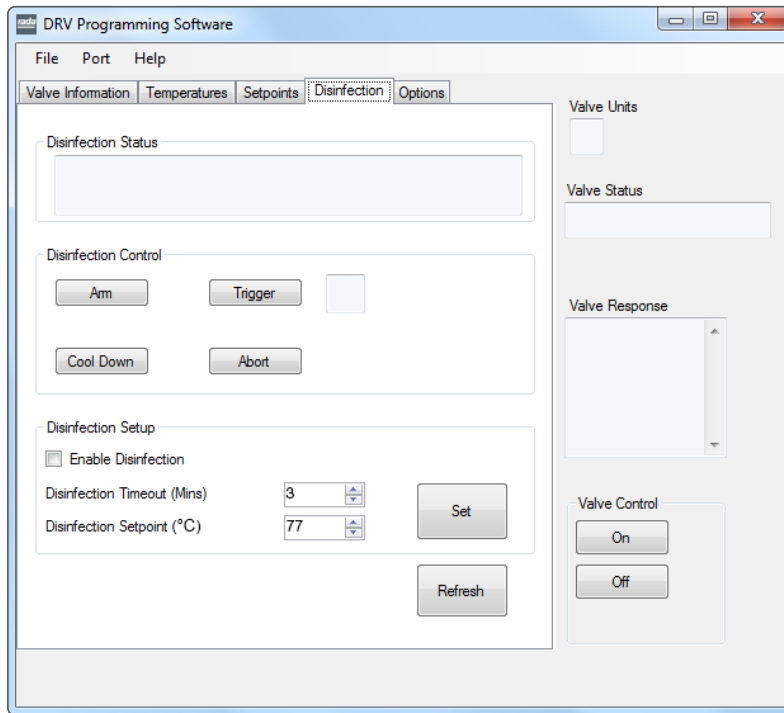

Disinfection Status

This shows the status of the disinfection cycle.

Disinfection Control

The controls for the **Disinfection Cycle**.

Disinfection Setup

The controls that enable a **Disinfection Cycle** to be run and sets the **Disinfection Timeout** feature.

Disinfection Setpoint

The temperature at which the thermal disinfection will be completed (must not exceed 185°F / 85°C).

Disinfection Setup

- 1 Click **Enable Disinfection** checkbox and set the **Disinfection Timeout** value.

Disinfection Timeout is the number of minutes the temperature alert and error displays are disabled to allow for disinfection and cool down of the blend circuit before switching back on automatically, i.e. if **Disinfection Timeout** is set to 30 minutes then the DRV80 has that time to complete the disinfection and cool down before entering an error condition and switching to full cold.

Please note the following:

- **Disinfection Timeout** starts when **Trigger** is pressed.
- During the **Disinfection Timeout** the disinfection and cool down must be completed manually and the DRV80 returned to **Setpoint** (normal operation within the setpoint limits).
- The **Disinfection Timeout** can be set up to a maximum of 1800 minutes (30 hours).

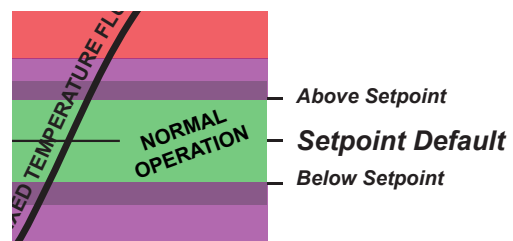

- 2 Switch **Valve Control** to **OFF**.
- 3 Click **Set** to transfer the values to the DRV80.
- 4 Click **Refresh** to force display and confirm the updated values.

Disinfection Cycle

Warning!



Due to the scalding temperature, the disinfection process must be supervised. The DRV80 should be monitored whilst in disinfection mode and no one should be allowed to approach within 3 meters of any affected outlets.

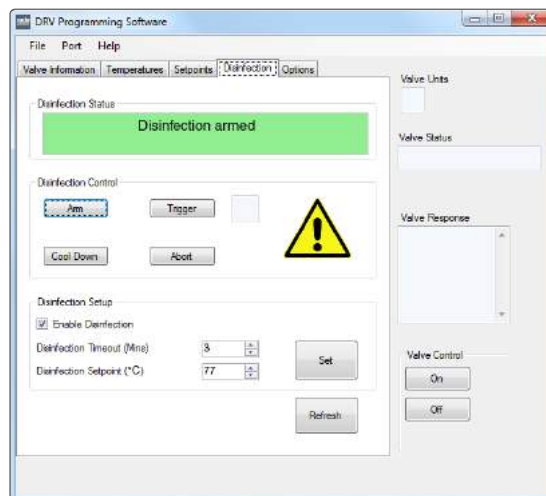

- 1 Click **Arm** when prepared for disinfection cycle, the **Disinfection Status** will confirm.

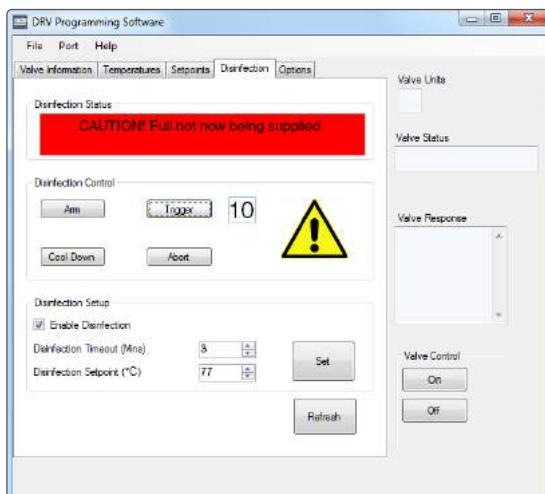

Temp Disinfection 77°C

- 2 Within 20 seconds, click **Trigger** to activate the disinfection, the **Disinfection Status** will confirm. (There is a 10 second countdown before full hot is supplied to the blend circuit. The display on the DRV80 changes to confirm the disinfection cycle is active.)



Armstrong International
 Parc Industriel Des Hants-Sarts, 2ème Avenue No. 4, Haerstal, B-4040, Belgium
armstronginternational.com/brain

EMERGENCY STOP! - Click **Abort*** at any time to stop the cycle.

Temp 48°C
Cooling Down

- 3 Click **Cool Down**. The display on the DRV80 changes to confirm the cool down mode. After cool down has been initiated, the blend circuit takes time to return to normal temperature. Drain the hot water using the last outlet of the blend circuit, or use a dump valve fitted near to the end of the blend circuit. Check with local water authorities with regard to water temperature limitations to drain. The time required to cool the blend circuit must be considered when setting the **Disinfection Timeout** period.
- 4 At the end of the **Disinfection Timeout** period, the DRV80 will return to normal operating mode and the alerts and errors will be re-enabled.

IMPORTANT! The DRV80 is locked in disinfection mode until one of the following actions has been performed:

- a. The **Disinfection Timeout** period has expired (automatic).
- b. The **Abort** button is pressed (manual).

Disinfection Timeline

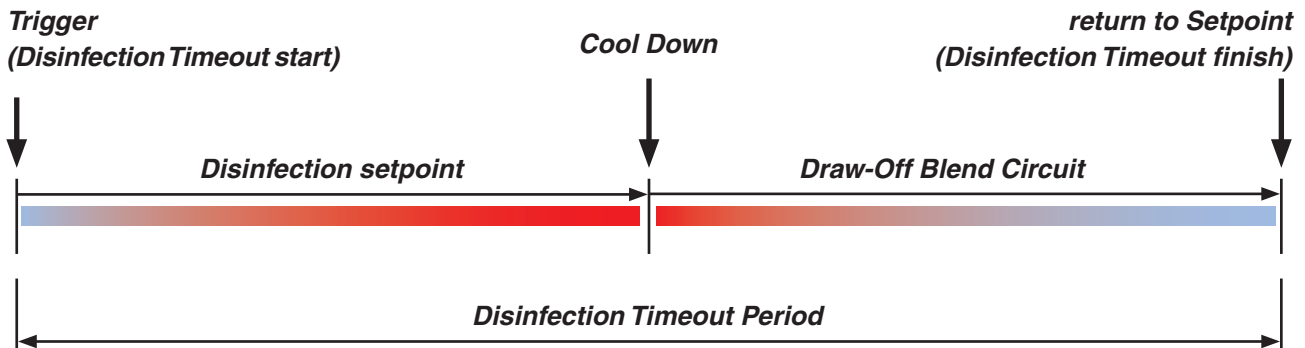

*Abort

If **Abort** is used when the cycle is disinfecting, the DRV80 switches to full cold and displays **Error Temp**. Cycle the power off / on to reset the DRV80, make sure the blend circuit is at a safe temperature before allowing any outlets to be used.



Armstrong International
Parc Industriel Des Hants-Sarts, 2ème Avenue No. 4, Haerstal, B-4040, Belgium
armstronginternational.com/brain

Disinfection Step by Step - 1 *(setting parameters for cycle)*

Follow these steps to determine the total disinfection cycle time and store that value in the *Disinfection Timeout* parameter of *The Brain® DRV Programming Software*. At the end, the parameters will be set to run all future disinfection cycles reliably.

You are about to run a test cycle to determine, in total, how long it takes to disinfect the blend circuit. Before you begin, make sure there is an adequate supply of hot water for this test. You will also require a reliable clock or stopwatch to monitor the duration of the test. Make sure all warnings, cautions and responsibilities on page 32 are observed during the test.

- 1 Click Enable Disinfection check box
- 2 Set *Disinfection Timeout* to **1800 minutes** (maximum).
- 3 Configure the disinfection setpoint as required (max 180 °F / 85 °C)
- 4 Click **Off** under *Valve Control*.
- 5 Click **Set**.
- 6 Click **Refresh** to confirm the settings.



MAKE SURE ALL OUTLETS ON BLEND CIRCUIT ARE NOT IN USE UNTIL TEST IS COMPLETE!
No one should be allowed to approach within 10 feet (3 meters) of any affected outlets.

- 7 Click **Arm**.
- 8 Click **Trigger** and start stopwatch or note the time of day.
- 9 Monitor the temperature and time until a satisfactory disinfection of the blend circuit has been achieved.
- 10 Click **Cool Down**.
- 11 Draw-off hot water from the blend circuit. Use either the last outlet on the circuit or a dump valve fitted near to the end of the circuit.
- 12 When the DRV80 temperature is within normal operation, stop the draw-off.
- 13 Click **Abort**.
- 14 Stop stopwatch or note the time of day. The time difference is the future *Disinfection Timeout* period.
- 15 Click **Off** under *Valve Control*.
- 16 Change *Disinfection Timeout* to new value.
- 17 Click **Set**.
- 18 Click **Refresh** to confirm.
- 19 Click **On** under *Valve Control*.

For all further disinfection cycles, use Step by Step - 2.

Disinfection Step by Step - 2 *(running a routine cycle)*

You are about to run a disinfection cycle of the blend circuit. Before you begin, make sure there is an adequate supply of hot water for the cycle. You will also require a reliable clock or stopwatch to monitor the duration of part of the cycle.

Make sure all warnings, cautions and responsibilities on page 32 are observed during the cycle.

- 1 Click **Off** under **Valve Control**.



MAKE SURE ALL OUTLETS ON BLEND CIRCUIT ARE NOT IN USE UNTIL TEST IS COMPLETE!
No one should be allowed to approach within 3 meters of any affected outlets.

- 2 Click **Arm**.
- 3 Click **Trigger**.
- 4 Start the stopwatch or make a note of the time of day. Monitor the temperature and time until a satisfactory disinfection of the blend circuit has been achieved.
- 5 Click **Cool Down**.
- 6 Draw-off hot water from the blend circuit. Use either the last outlet on the circuit or a dump valve fitted near to the end of the circuit.
- 7 When the DRV80 temperature is within normal operation, stop the draw-off.
- 8 Allow the DRV80 to return to normal operation automatically.

IMPORTANT! - CHANGES TO THE PLUMBING SYSTEM.

Any alteration to the plumbing system that may affect the blend circuit may, as a consequence, also affect the Disinfection Timeout period. Repeat all of Step by Step -1 to maintain a reliable disinfection cycle for the system.



Armstrong International
Parc Industriel Des Hants-Sarts, 2ème Avenue No. 4, Haerstal, B-4040, Belgium
armstronginternational.com/brain

Options

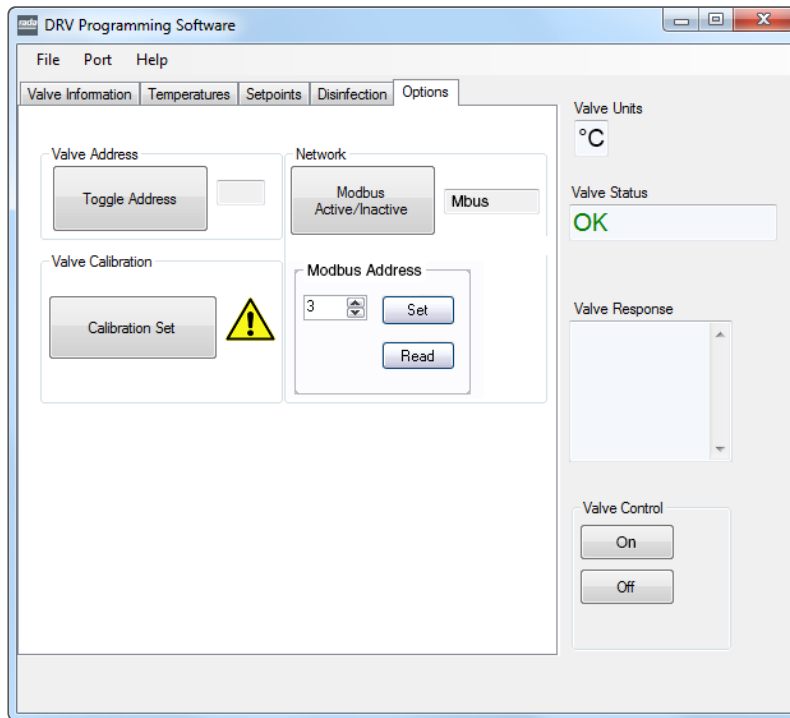

Valve Address

The **Address** of the DRV80 as used by **BrainScan®** can be set to **Standard (Std)** or **Alternate (Alt)**. This allows the use of two DRV80s on one serial line.

Set the first DRV80 to **Std** and the second DRV80 to **Alt**.

- 1 Switch **Valve Control** to **OFF**.
- 2 Click Toggle Address .
- 3 Switch **Valve Control** back **ON**.

Network

Click the button to toggle to **Bscan** if the DRV80 is connected to **BrainScan®**.

Click the button to toggle to **Mbus** if the DRV80 is connected to a **Modbus network**. The **Modbus Address** number is determined by the configuration of the network. The number is between **3 and 32**.

(If you are in any doubt contact the system administrator before adjusting this setting.)

Valve Calibration

Must be used when replacing the following parts:

- **Proportioning Assembly**
- **PCB**
- **Drive Housing**
- **Gear Drive Assembly**

(see Preventative Maintenance and Fitting Spare Parts for further details)

Do not use Calibration Set for any other reason. If in doubt contact Armstrong for further advice.

DRV80 Display Alerts

Temp High 53 °C
Setpoint 49 °C

Outlet temperature exceeds the **above setpoint** value. This condition causes a relay to be activated. (if the Activate Relay on Alert box is checked - see page 29)

Temp Low 38 °C
Setpoint 49 °C

Outlet temperature is less than the **below setpoint** value. This condition causes a relay to be activated. (if the Activate Relay on Alert box is checked - see page 29)

DRV80 Error Messages

See *Troubleshooting...*



Armstrong International
Parc Industriel Des Hants-Sarts, 2ème Avenue No. 4, Haerstal, B-4040, Belgium
armstronginternational.com/brain

Connectivity

The integral RS485 Serial Port (CN2 on the DRV80 PCB) can be used to connect to either **BrainScan®** or directly to **Building Automation Systems (BAS)** which operates on a **Modbus RTU** protocol.

See **Options** screen on page 38 for details on how to switch DRV80 for either **BrainScan®** or **Modbus**.

BrainScan® (not available in Europe)

BrainScan® is an optionally selected control module from Armstrong which enables an interface with **Building Automation Systems (BAS)** which utilize **Modbus, Bacnet™** or **LonWorks™** protocols via the use of specific ProtoCessor cards.

BrainScan® also has an ethernet port and operates as a web server for remote network access.

BrainScan® includes remote hot water supply, cold / recirculation water supply, blended water outlet temperature outputs and is supplied with a system graphic, memory card for data storage and web based software.

BrainScan® includes terminals for additional installer supplied RTDs, pressure transducers and pulse type flow meters and this data can be forwarded via the **BrainScan®** interface.

A separate BrainScan® specific Installation, Operation and Maintenance (IOM) Guide is available upon request. Please consult factory or visit:

www.armstronginternational.com/sites/default/files/resources/documents/IOM-690.pdf

Modbus

Modbus – DRV80 can be configured to communicate directly with BAS which utilize Modbus RTU.

When configured for Modbus the DRV80 becomes a **Remote Terminal Unit (RTU)**.

When connected directly to a BAS using Modbus RTU, the DRV80 will be assigned a unique network address which is programmed via the integral DB9 external port.

A separate Modbus specific Installation, Operation and Maintenance (IOM) Guide is available upon request. Please consult factory or visit:

www.armstronginternational.com/sites/default/files/resources/documents/IOM-776.pdf



Armstrong International
Parc Industriel Des Hants-Sarts, 2ème Avenue No. 4, Haerstal, B-4040, Belgium
armstronginternational.com/brain

System Performance

For effective DRV80 performance, the DRV must be able to experience a minimum flow and a minimum temperature differential between its inlet and outlet supplies when the system is in **zero demand**.

Zero demand is defined as periods when there is no mixed water outlet usage on the system.

Pre-installation calculations should have already determined the system heat loss characteristics. For optimum performance the DRV80 requires a minimum of 1°C differential between the digital display on the unit (the outlet temperature) and the thermometer which is installed on the system return line.

When there is no system draw-off, the DRV80 reverts to a zero demand. The recirculation temperature is continuously monitored and adjusted appropriately by the DRV80. The circulating pump must operate continuously, the DRV80 requires a minimum flow of 38 l/m.

Pump Capacity

The circulating pump is only required to keep water gently moving around the system. The pump should be sized and selected to overcome the system resistance (feet of head) at the minimum specified flow rate of 38 l/m while also accounting for system heat loss.

System Safety Measures

System safety measures such as the installation of an aquastat linked to the circulating pump which shuts the pump off if the system exceeds a given temperature setpoint is not required. DRV80 can be programmed to issue suitable alerts and / or system hot water shutoffs (DRV80) and shutdowns (Independent Solenoid Valve).



Armstrong International
Parc Industriel Des Hants-Sarts, 2ème Avenue No. 4, Haerstal, B-4040, Belgium
armstronginternational.com/brain

Preventative Maintenance and Fitting Spare Parts



Warning! Isolate power to the DRV80. Ensure that the circulating pump is not operating.

DRV80 components should be inspected annually, or more frequently where acknowledged site conditions such as high mineral content water dictate.

Each DRV80 has a serial number that is maintained on file with the technical department at Armstrong.

For any installation, operation, maintenance or technical support details not covered in this guide, please call our Technical Department quoting the model and / or serial number.

Batteries

Batteries are supplied to ensure the DRV switches to **Full Cold** in the event of a primary power supply failure, they should **not** be considered to be a backup power supply.

Battery life is variable depending upon usage. A battery error message appears on the DRV display when they require replacing.

Where primary power supply failure occurs regularly or the DRV is installed within a supply system where safety is critical, the batteries **must** be changed at least every 12 months as part of an annual maintenance routine.

In noncritical systems or where battery usage is low, longer replacement cycles may be considered up to a maximum of 5 years. Inspection of critical components and / or assemblies.

O - Rings / Seals

All 'wetted' O -Rings / Seals must be replaced at least every 12 months as part of an annual maintenance routine. In systems where water quality conditions are poor, more frequent replacement may be required.

Strainers

All supply strainers must be thoroughly cleaned at least every 12 months as part of an annual maintenance routine. Cleaning includes physically taking the strainer screen / basket out of the body and cleaning as well as flushing water through the body. In systems where water quality conditions are poor, more frequent cleaning may be required.



Armstrong International
Parc Industriel Des Hants-Sarts, 2ème Avenue No. 4, Haerstal, B-4040, Belgium
armstronginternational.com/brain

DRV80 Disassembly



Warning!

Before disassembly observe the following:



- Isolate the electrical supply to the DRV80.
- Isolate the water supplies to the DRV80.
- Allow the hot water inlet to cool sufficiently to reduce the risk of injury through contact with the hot pipe or DRV.

Step 1

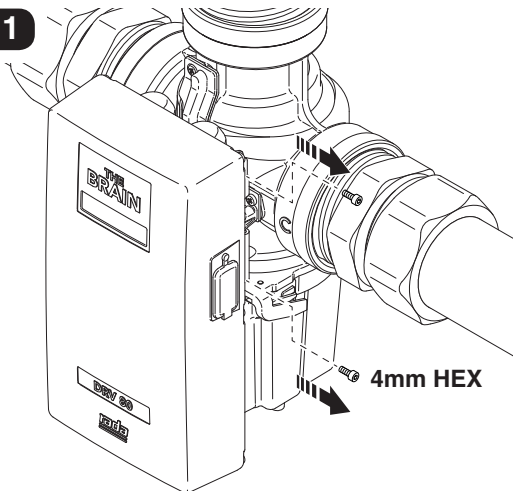

Step 2

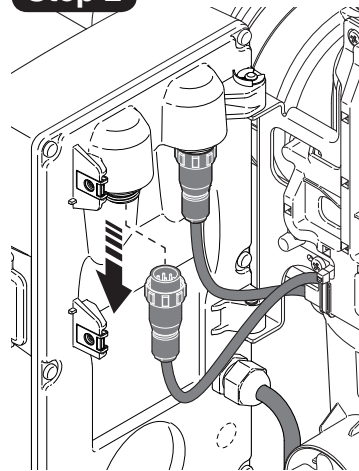

Failure to disconnect the incoming power supply before removing the plugs may result in product damage. Any damage caused in this way is not covered by the *Limited Warranty*. (See back page for full details.)

Step 3

Note! Retain Clips if replacing electronics module

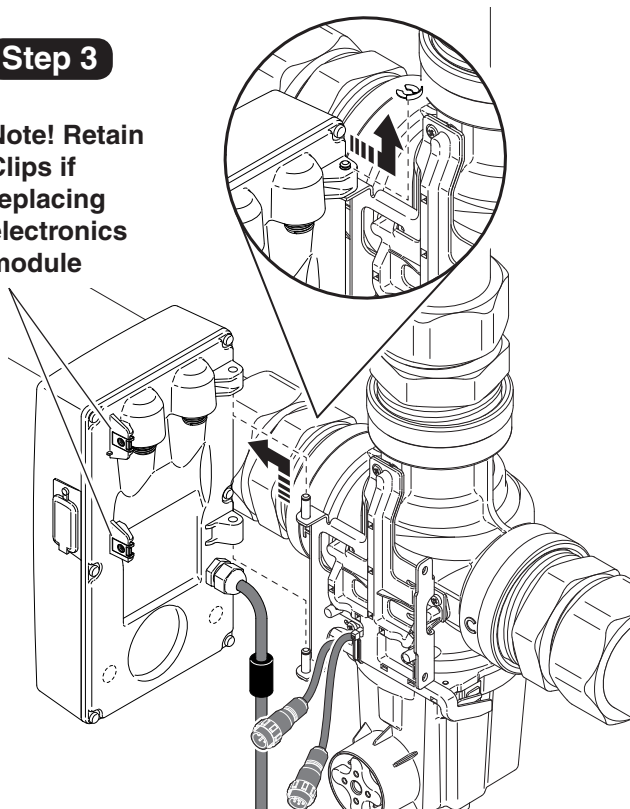

Step 4

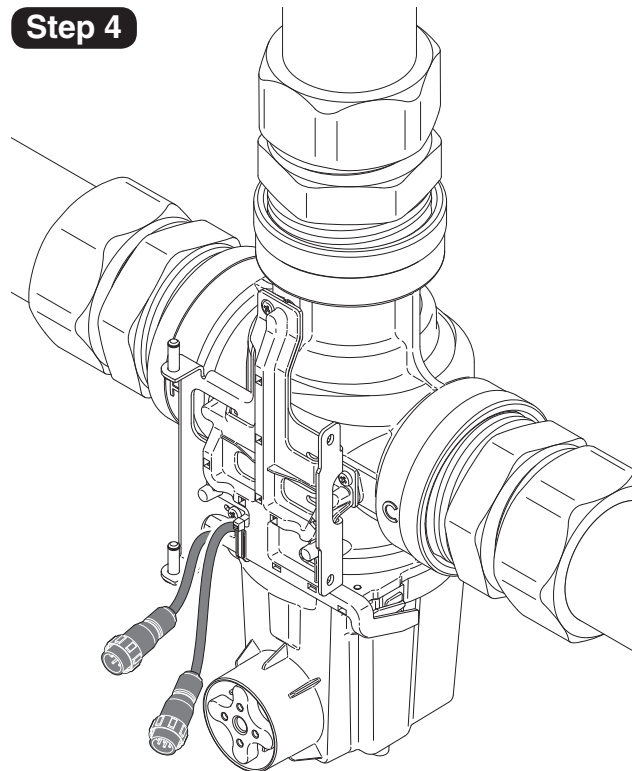

Armstrong International
Parc Industriel Des Hants-Sarts, 2ème Avenue No. 4, Haerstal, B-4040, Belgium
armstronginternational.com/brain

Electronics Module

DRV80 Electronics Module Spare Parts

- D57395 Electronics Module
- D57396 PCB
- D45781 LCD
- D51819 Front Cover
- D77504 Thermistor Loom

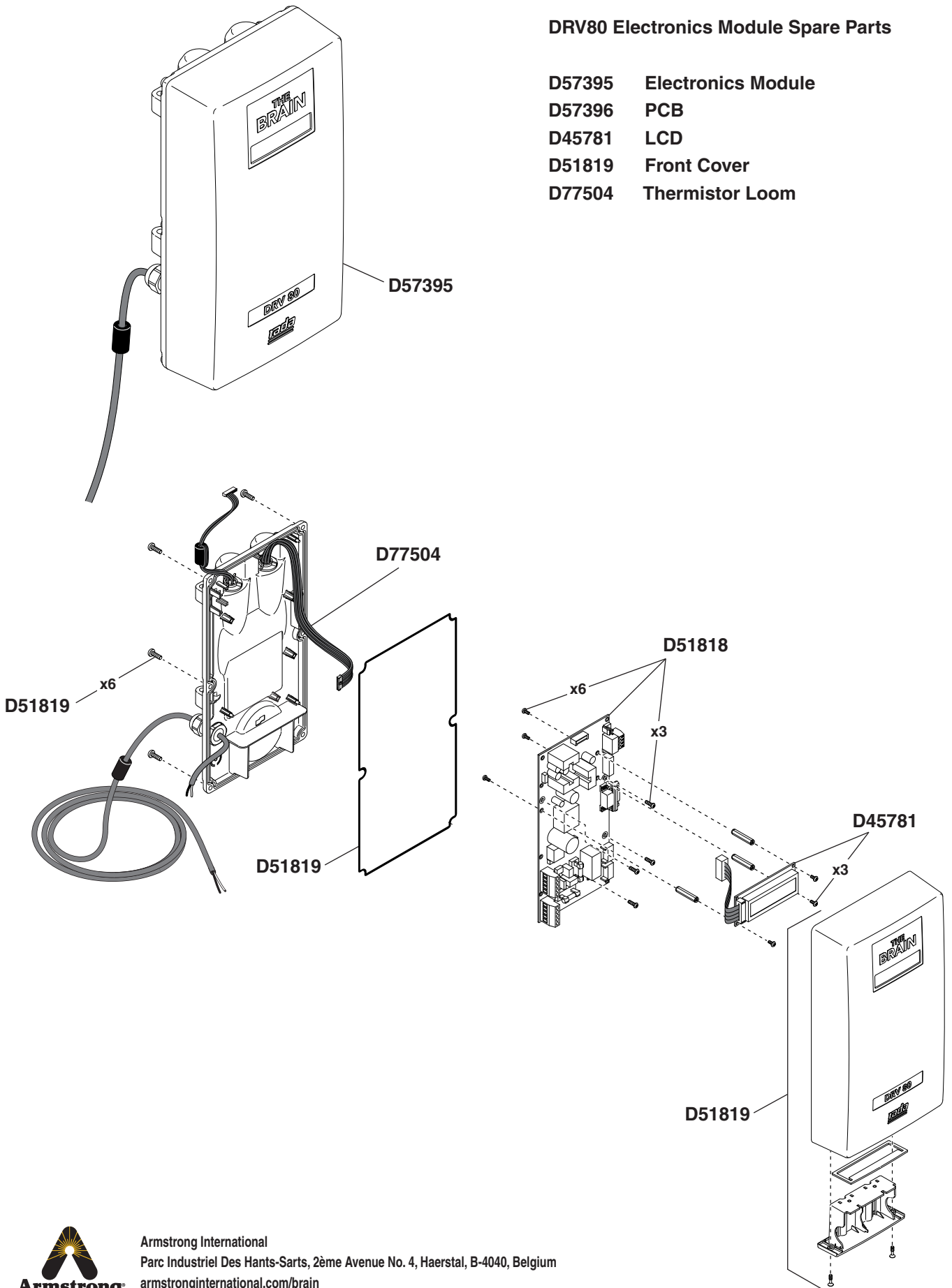

Armstrong International
 Parc Industriel Des Hants-Sarts, 2ème Avenue No. 4, Haerstal, B-4040, Belgium
armstronginternational.com/brain

Step 1

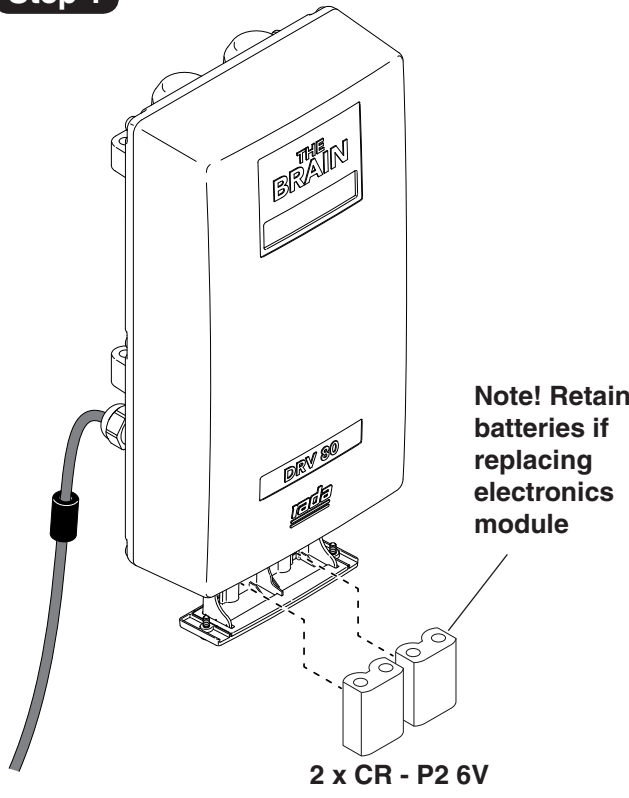

Step 2

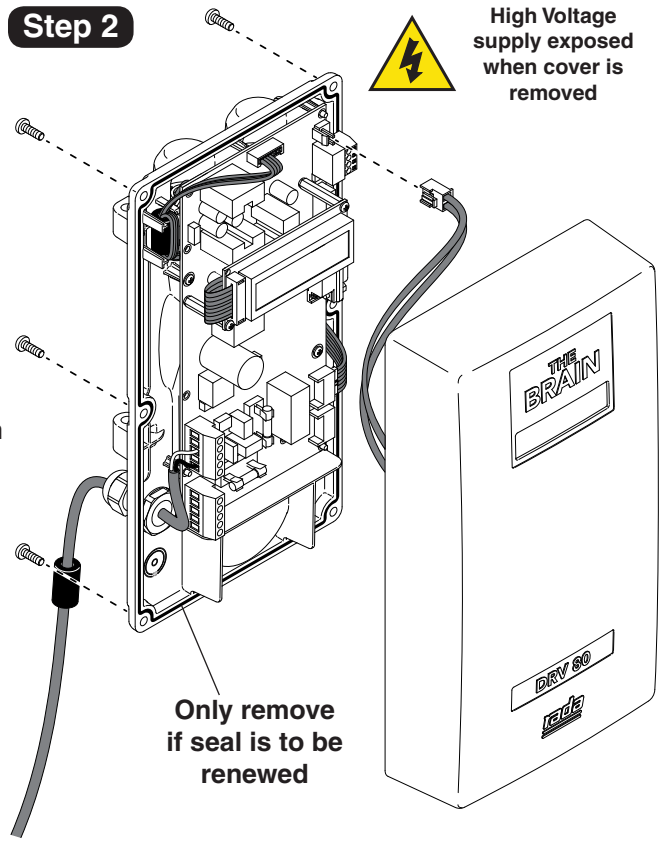

Step 3

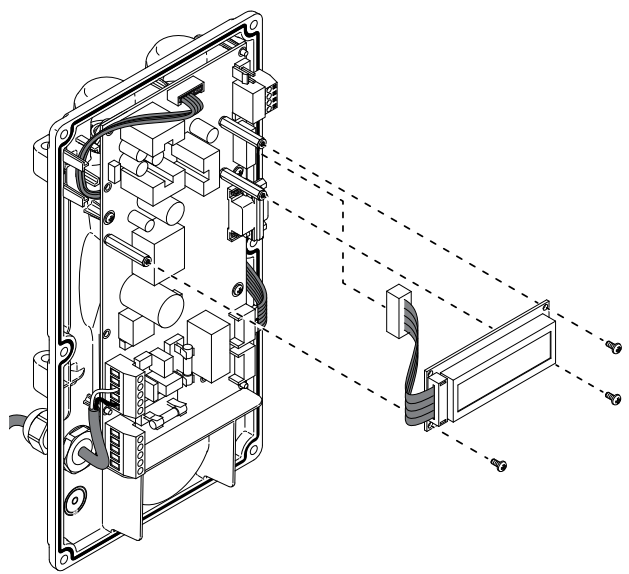

Step 4

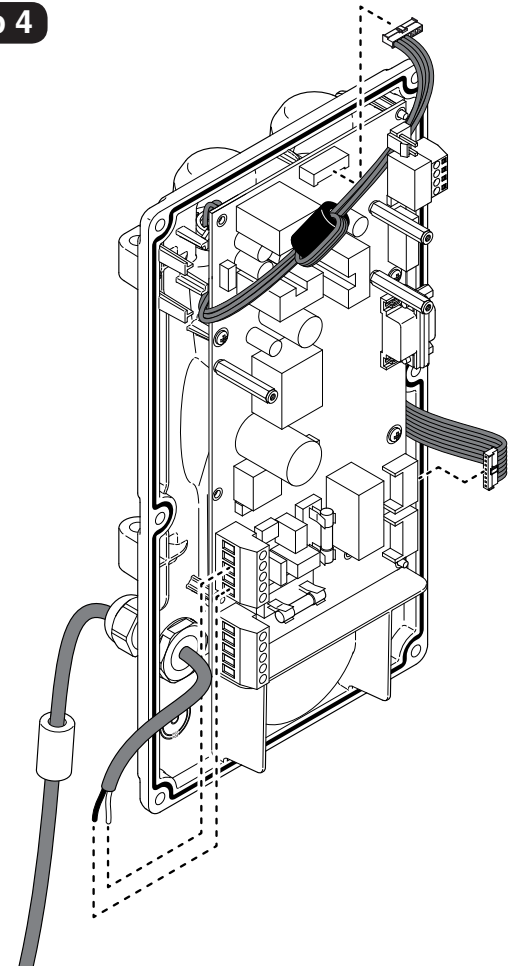

Armstrong International
 Parc Industriel Des Hants-Sarts, 2ème Avenue No. 4, Haerstal, B-4040, Belgium
armstronginternational.com/brain

Step 5

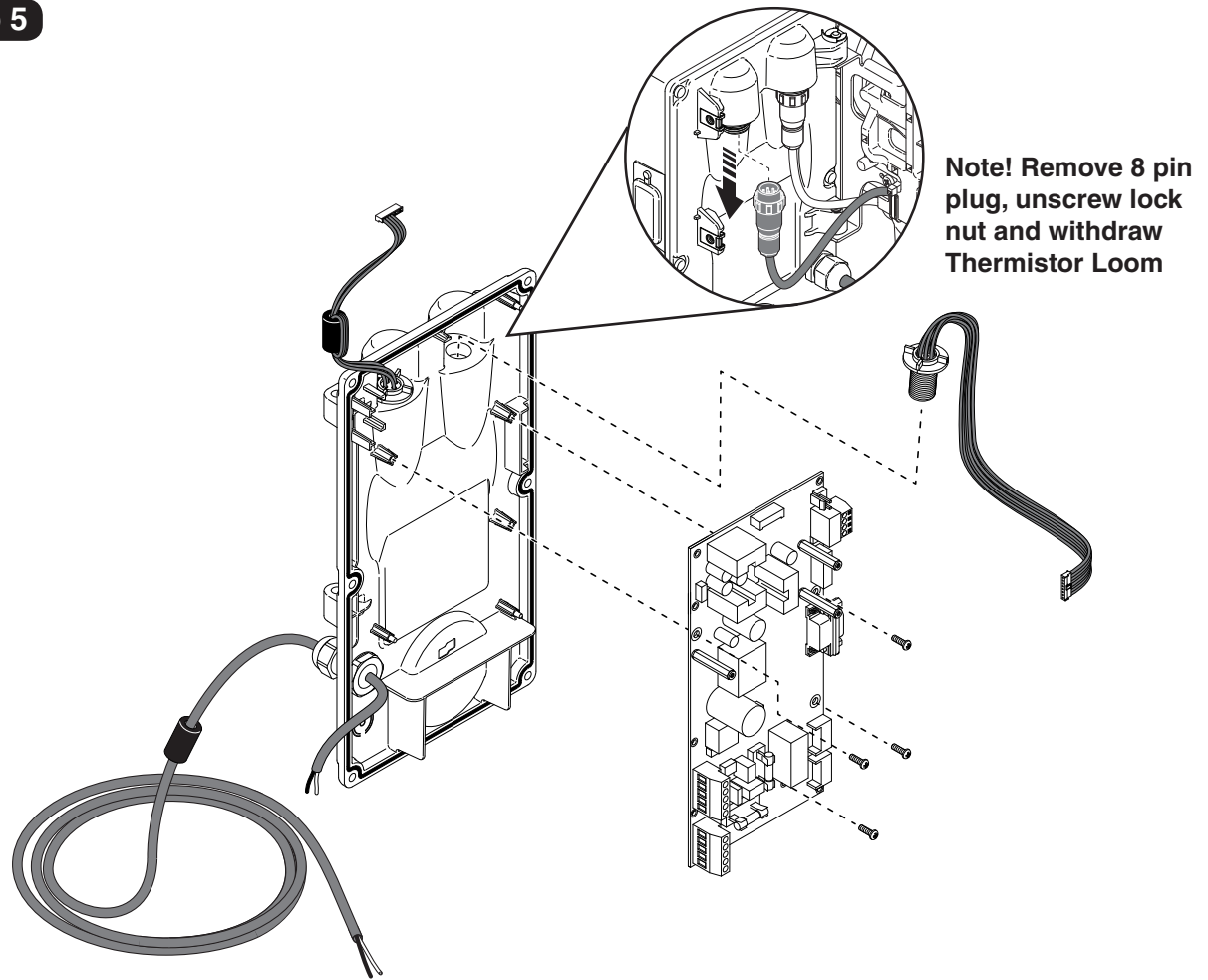

Step 6

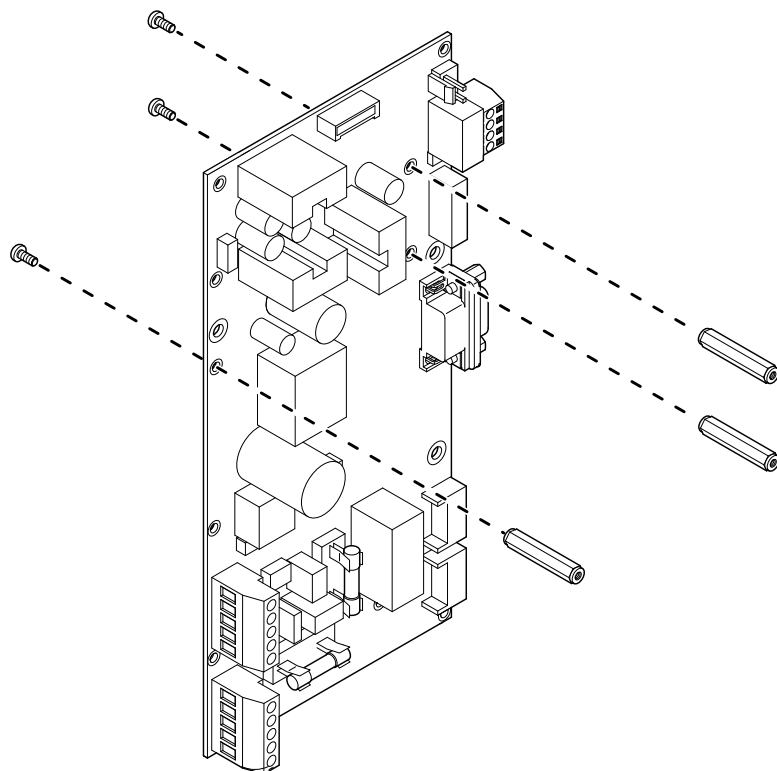

PCB Connections

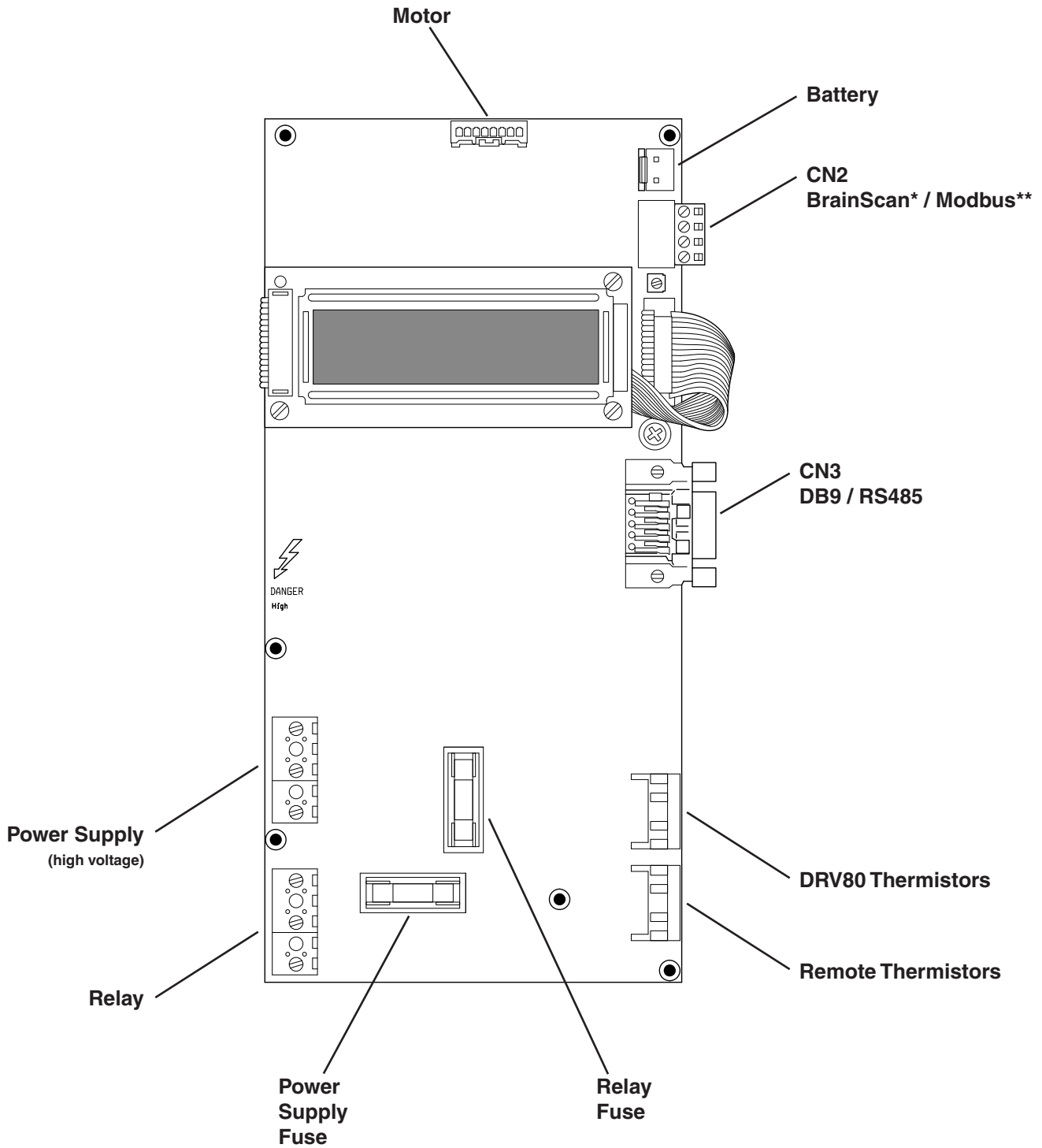

* See separate guide - www.armstronginternational.com/sites/default/files/resources/documents/IOM-690.pdf

**See separate guide - www.armstronginternational.com/sites/default/files/resources/documents/IOM-776.pdf



Armstrong International
 Parc Industriel Des Hants-Sarts, 2ème Avenue No. 4, Haerstal, B-4040, Belgium
armstronginternational.com/brain

DRV

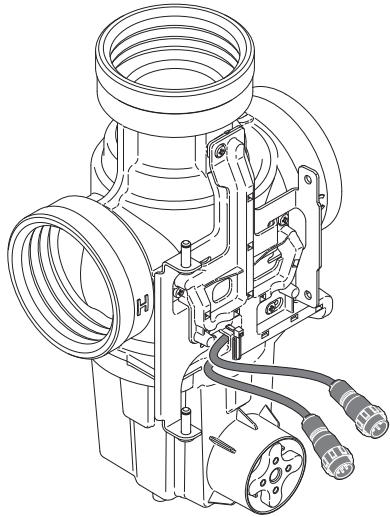

DRV80 DRV Spare Parts

- D51820 Motor Cover
- D51821 Magnetic Rotor
- D45786 Stepper Motor
- D51822 Cable Loom Assembly
- D51823 Proportioning Assembly
- D51824 Drive Housing
- D68927 Gear Drive Assembly
- D45791 Drain Plug
- D51825 Seal Pack
- D51826 Screw Pack

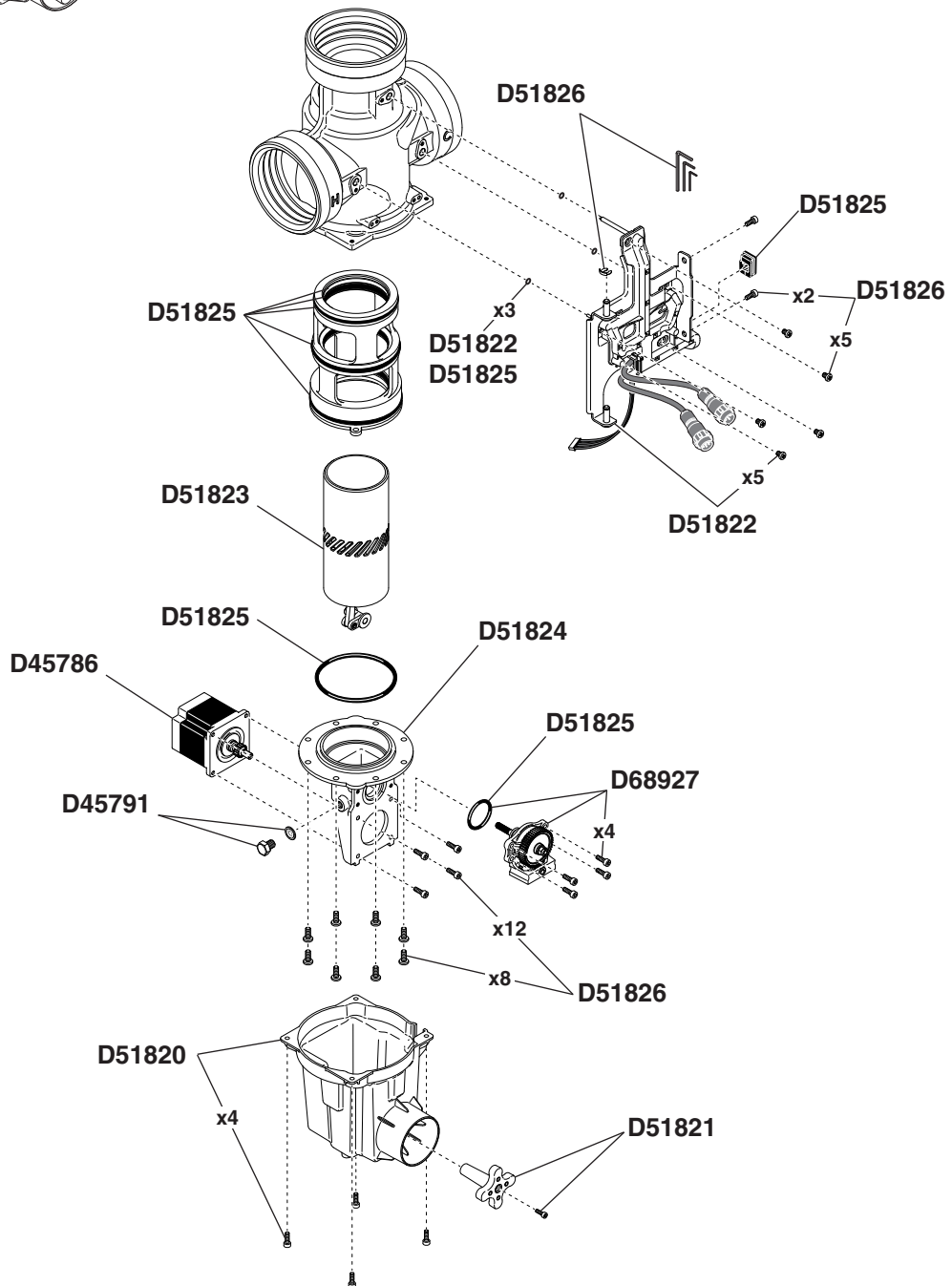

Step 1

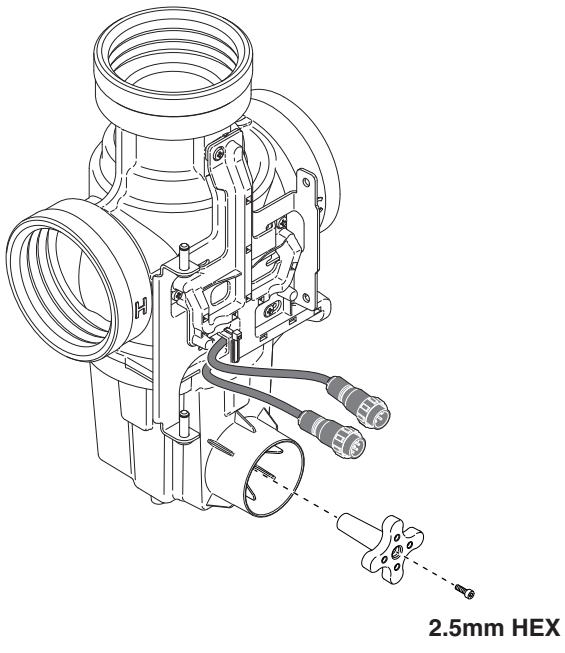

Step 2

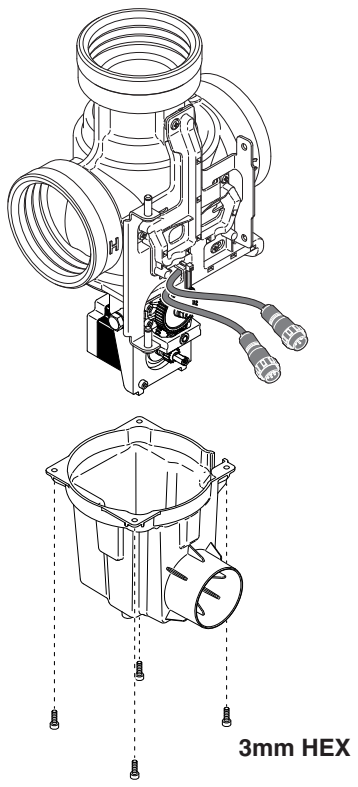

Step 3

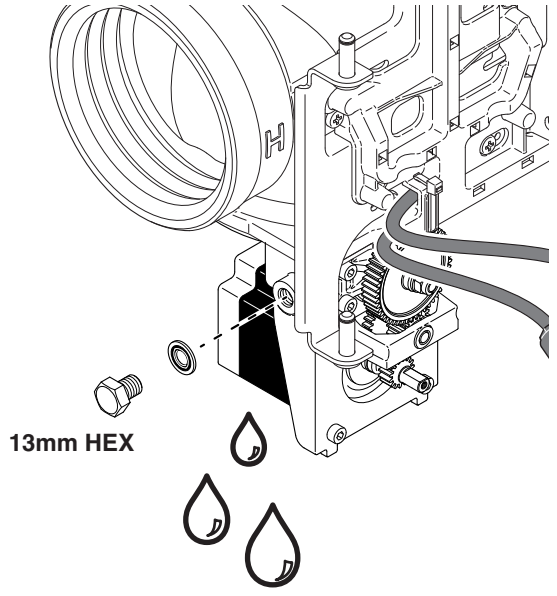

Step 4

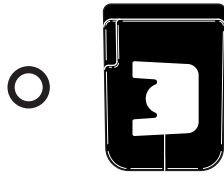
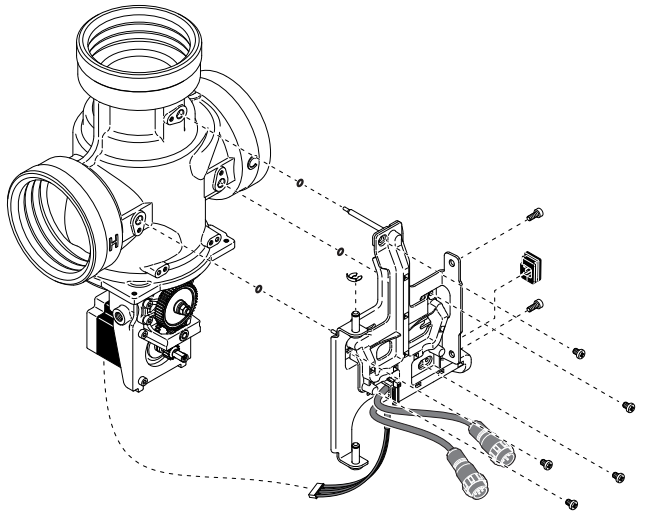

Seals shown 1:1 when printed at Full Scale



Armstrong International
 Parc Industriel Des Hants-Sarts, 2ème Avenue No. 4, Haerstal, B-4040, Belgium
 armstronginternational.com/brain

Step 5

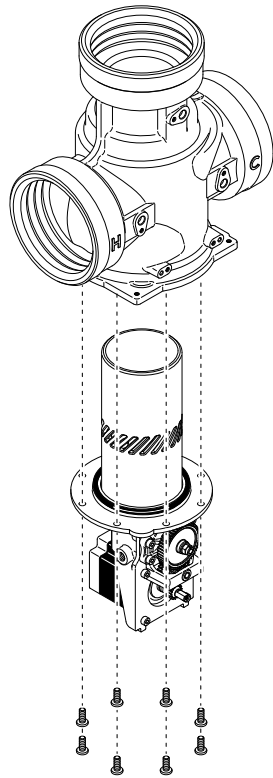

Step 6

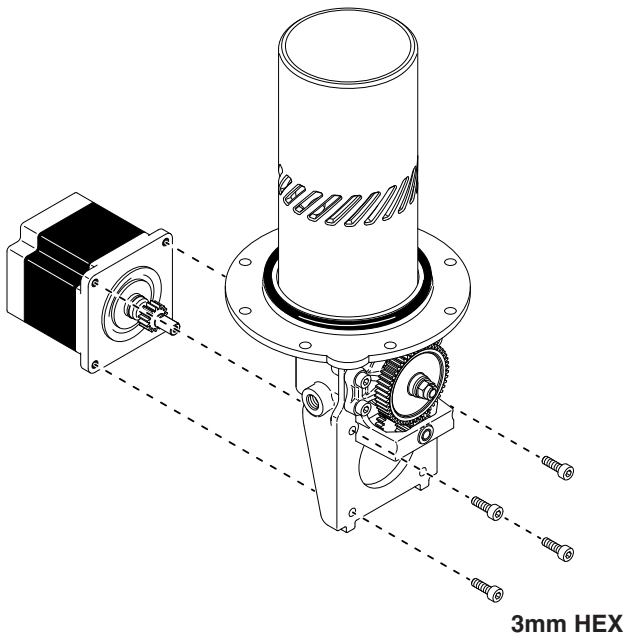

Armstrong International
Parc Industriel Des Hants-Sarts, 2ème Avenue No. 4, Haerstal, B-4040, Belgium
armstronginternational.com/brain

Step 7

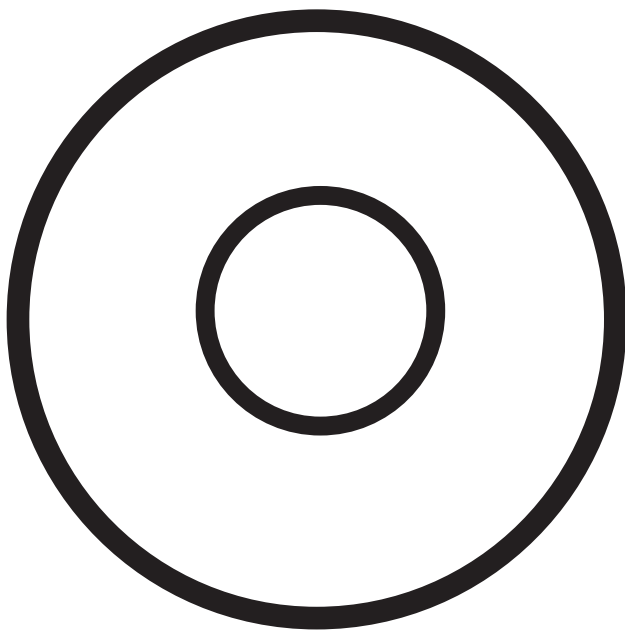
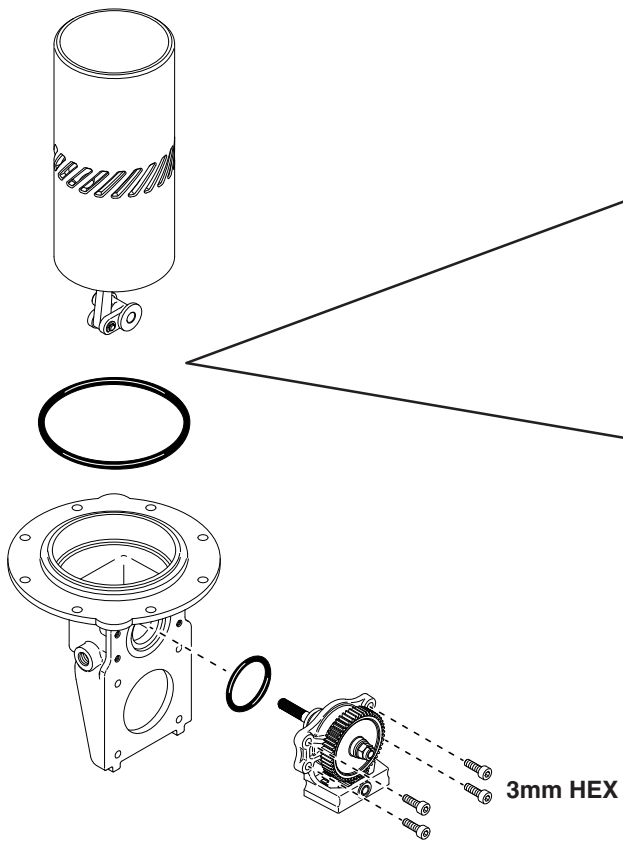

Step 7a

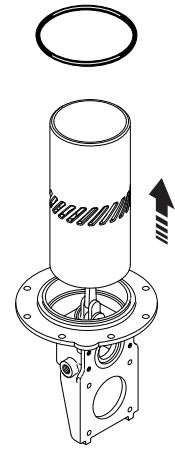

Step 7b

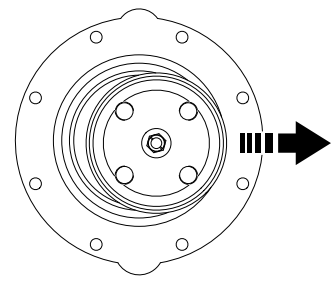

Step 7c

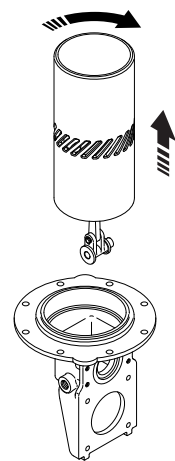

Seals shown 1:1 when printed at Full Scale

Step 8

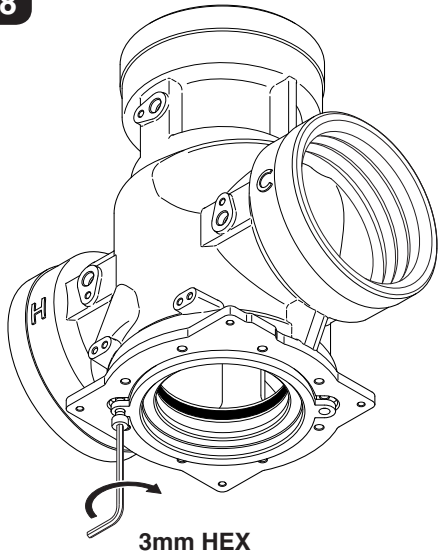

Use one of the 3mm Hex screws to assist in removing the cartridge.

Step 9

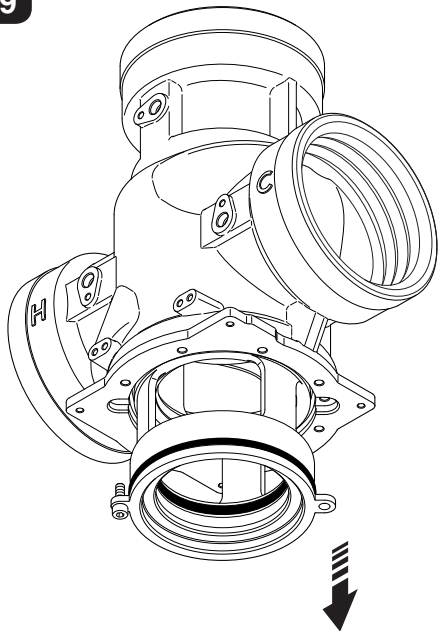

Cartridge will fall when loose.



Armstrong International
Parc Industriel Des Hants-Sarts, 2ème Avenue No. 4, Haerstal, B-4040, Belgium
armstronginternational.com/brain

Step 10

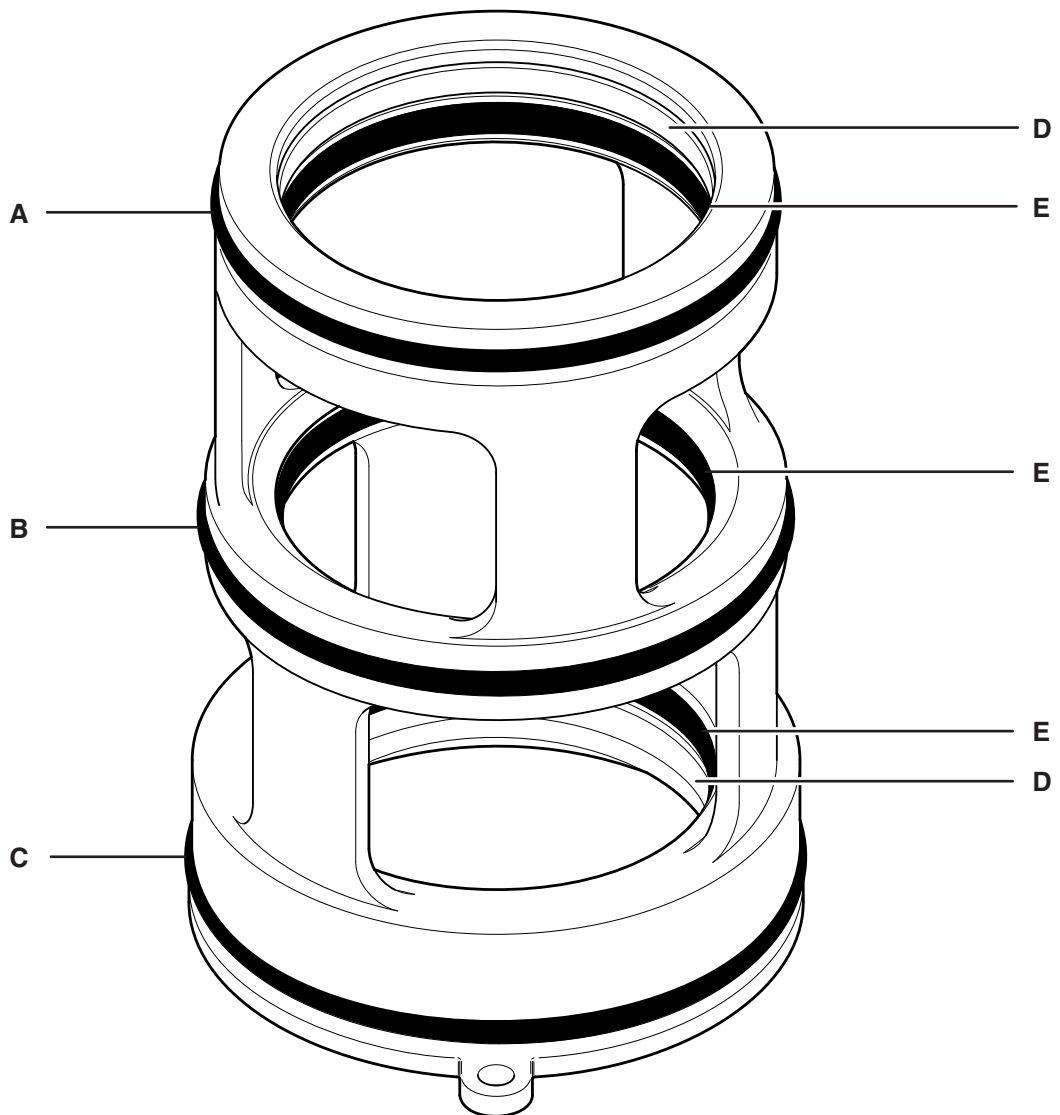

D45792 Cartridge Seal Pack
(Cartridge not included)



Only use silicone based lubricants on rubber seals.



Armstrong International
Parc Industriel Des Hants-Sarts, 2ème Avenue No. 4, Haerstal, B-4040, Belgium
armstronginternational.com/brain

continued...

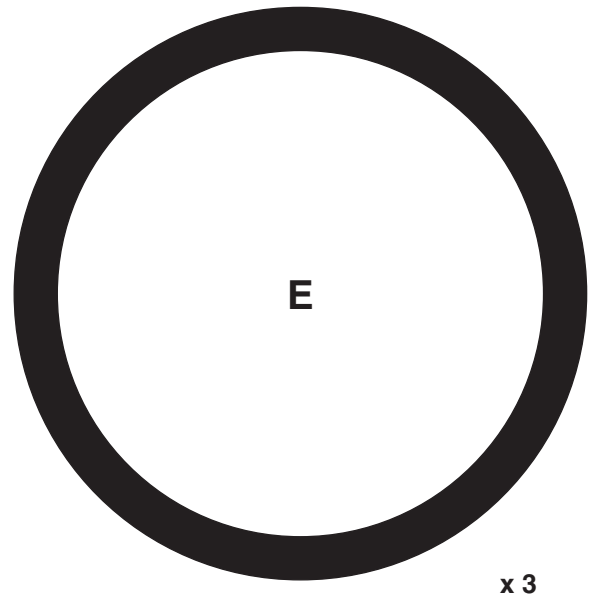
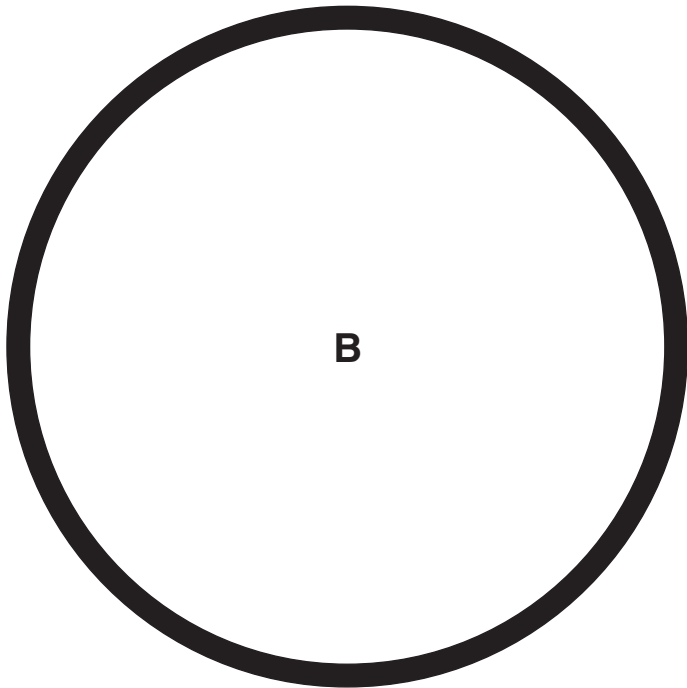
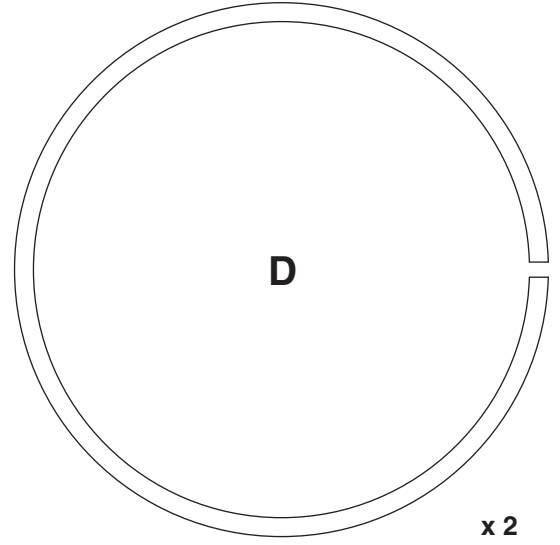
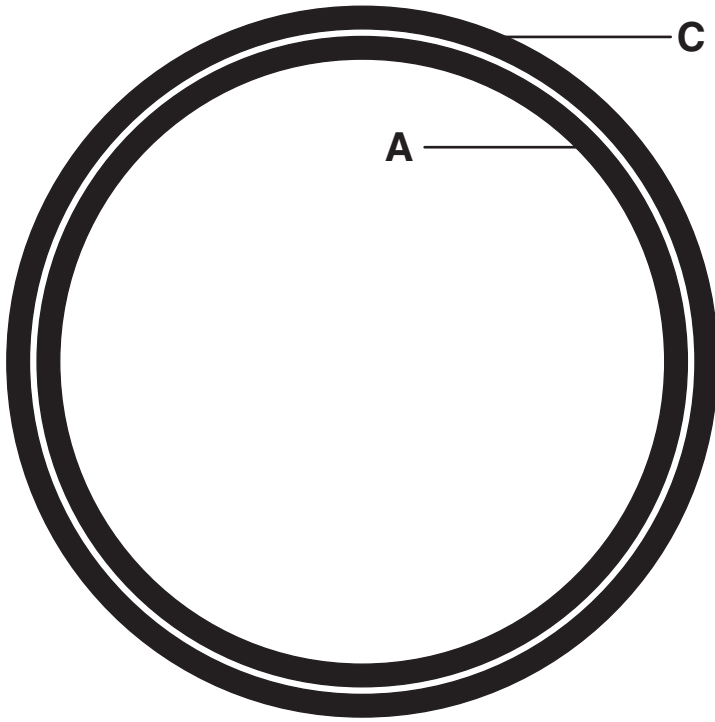

Seals shown 1:1 when
printed at Full Scale



Armstrong International
Parc Industriel Des Hants-Sarts, 2ème Avenue No. 4, Haerstal, B-4040, Belgium
armstronginternational.com/brain

Step 11

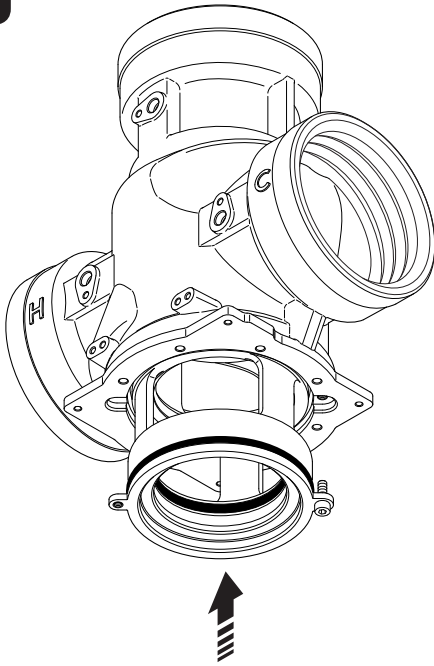

Step 12

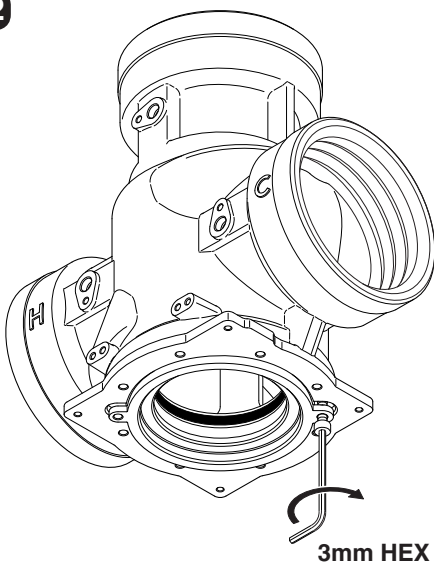

*Use one of the 3mm Hex screws to assist in refitting the cartridge.
Remove the screw when the cartridge is inserted fully.*



Step 13

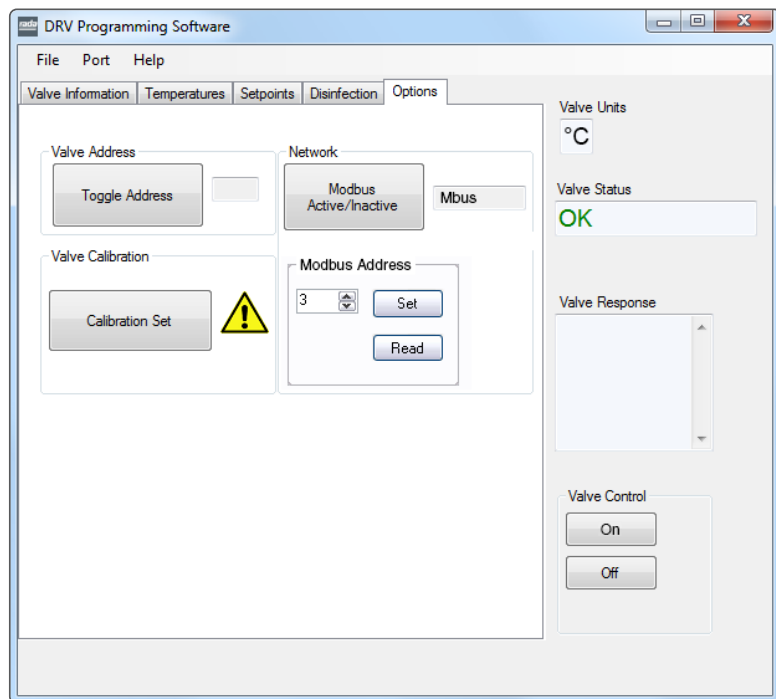
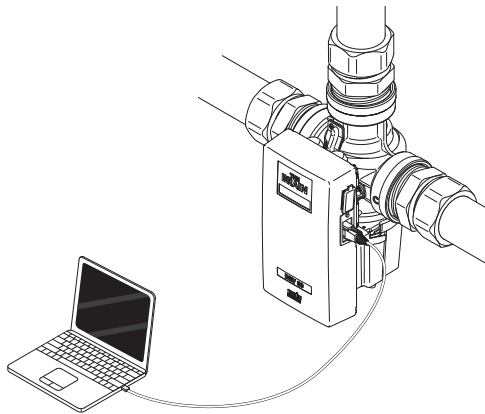

Valve Calibration

Must be used after replacing the following parts:

- Proportioning Assembly
- PCB
- Drive Housing
- Gear Drive Assembly

- 1 Turn power on to the reassembled DRV80 and connect to a Laptop / PC device.
- 2 Run the *The Brain® DRV Programming Software* and go to the *Options* screen.
- 3 Click *Off* under *Valve Control*.
- 4 Click *Calibration Set*.

continued...

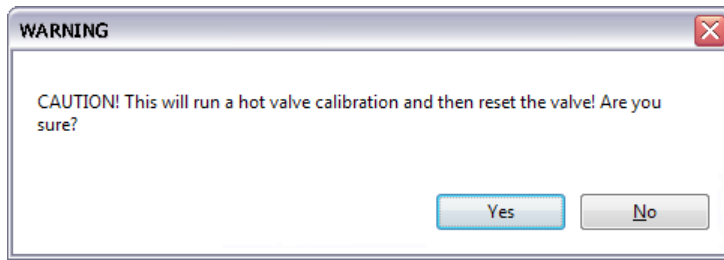

- 5 Click **Yes** to proceed with the calibration. Monitor the DRV80 display.

Calibrate HotEnd
Valve Reset...

Rada
DRV80

Temp.	48 °C
Setpoint	49 °C

- 6 Wait for the DRV80 to reset.



Troubleshooting

Contents

DRV80 Display Errors.....	59
Common Faults	
<i>“Blend temperature rises when system is in zero demand”</i>	62
<i>“Outlet temperature fluctuates more than $\pm 2^{\circ}\text{C}$”</i>	63
<i>“LCD Display shows any of the following”</i>	64
<i>“Blend circuit does not fully return to normal within the Disinfection Timeout period”</i>	65
<i>“Constant difference between blend circuit temperature reading and DRV80 temperature display”</i>	66
<i>“Unable to adjust outlet temperature”</i>	67
<i>“No display”</i>	68
<i>“No display or no control”</i>	68
<i>“Cannot read the LCD display”</i>	69
<i>“High pitched noise from DRV80”</i>	70
<i>“Water leaking from DRV80”</i>	71



DRV80 Display Errors

Emergency Mode
Setpoint 49 °C

Maintenance to the DRV80 internal mechanism is required. DRV80 continues to operate safely, but with reduced performance. Check for the following:

- Motor damage or signs of wear
- Proportioning Assembly damage or signs of wear
- Debris in the Drive Housing
- Anything that could impair the movement of the Proportioning Assembly

If this mode is not addressed then it is likely the DRV80 will stop working and display any of the errors below.

Temp 49 °C
Error PCB 0

Indicates the PCB has failed, replace the PCB.

P/N - D57396 PCB, or

P/N - D57395 Electronics Module

see pages 43-46.

Temp 49 °C
Error PCB 5

Temp 49 °C
Error PCB 16

Temp 49 °C
Error PCB 32

Temp 49 °C
Error PCB 0 + Temp 49 °C
Error Reset 6

Indicates the PCB has failed. Turn power off for 10 seconds and restart. If the error persists, replace the PCB.

P/N - D57396 PCB, or

P/N - D57395 Electronics Module

see pages 43-46.

+ Temp 49 °C
Error Reset 8

+ Temp 49 °C
Error Reset 37

+ Temp 49 °C
Error Reset 40

+ Temp 49 °C
Error Reset 90



Temp 49°C	+	Temp 49°C
Error Thermistor		Error Check 4

Indicates thermistor / cable loom failure. Turn power off for 10 seconds and restart. If the error persists, check for the following.

- Connectors from DRV to electronics module are disconnected or wet
- Thermistors are loose

If the problem persists, replace the thermistor loom.

P/N - D77504 Thermistor Loom, or

P/N - D57395 Electronics Module

see pages 44-46.

Temp 49°C
Error Temp 3

Temp 49°C
Error Temp 7

Outlet temperature exceeds the **Error Temp** value. This condition causes the DRV80 to switch to full cold. Check for the following:

- Internal seal damage
- Debris in the internal mechanism
- Internal mechanism damaged / disconnected

Temp 49°C	+	Temp 49°C
Error Drive		Error Check 60

+	Temp 49°C
	Error Check 70

Indicates motor / cable loom failure or a malfunction of the positioning sensor. Reset the DRV80. If the error persists, check for the following:

- Electronics module is assembled to the DRV correctly
- Dirt or debris in gear mechanism
- Dirt or debris around motor
- Motor is disconnected
- Magnetic rotor is not coupled to the motor
- Proportioning Assembly is sticking or has seized
- Motor is loose
- Gear Drive assembly is loose

Replace in the following order if the problem still persists after each:

1. **P/N - D45787 Cable Loom**
2. **P/N - D57395 Electronics Module**
3. **P/N - D51821 Magnetic Rotor**
4. **P/N - D45786 Stepper Motor**

see pages 43-50.

Temp 49°C	+	Temp 49°C
Error Battery		Error Check 41

Indicates the batteries are flat or disconnected. Check for the following:

- Battery is connected to PCB
- Battery connections, signs of wear or debris / corrosion
- Batteries are at minimal power or flat

Replace batteries (see **Preventative Maintenance and Fitting Spare Parts** on page 42. Do not use rechargeable batteries)

Temp 1%\$ °C
Setpoint 43 °C

Rogue characters appear on display. Reset DRV80, if the error persists, replace LCD.

P/N - D45781 LCD

See pages 43-45

Temp 48 °C
Setpoint 49 °C

Brightness of LCD. Adjust setting on PCB. (See **Common Faults - Cannot read the LCD display** on page 69.



No power to DRV80. Check circuit breaker and electrical supply. Check wiring connections at power supply terminal block on PCB (see page 47). Check power supply fuse on PCB (see page 47). If problem persists, replace PCB and / or LCD.

P/N - D45781 LCD, or

P/N - D57396 PCB

See pages 43-46



Common Faults

Problem: “Blend temperature rises when system is in zero demand...”

DRV80 display errors

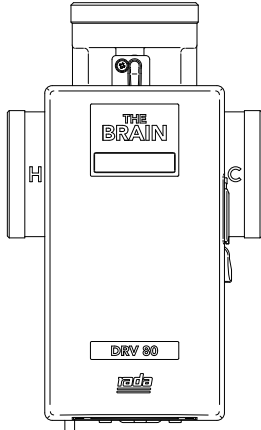

Temp 49 °C
Error Temp 3

Temp 49 °C
Error Temp 7

These are the most likely error messages to be displayed during this problem. For the most probable causes and solutions see **DRV80 Display Errors** on page 60.

If any other error message is displayed see **DRV80 Display Errors** on pages 59-61.

Check blend circuit flow rate.

Flow rate is less than 38 l/m. Reset circuit flow rate and check for the following:

- Air locks
- Blocked strainers
- Closed valves
- Pump failure

Check mixed return temperature.

Minimum recirculation loop temperature loss = 1°C

Checkvalves

Check circuit to make sure checkvalves are correct positioned and operating normally. (See **Piping Diagrams** on pages 12-15)

Water pressure

Make sure supply pressures are balanced. Make sure mixed return is flowing correctly to hot water supply inlet.

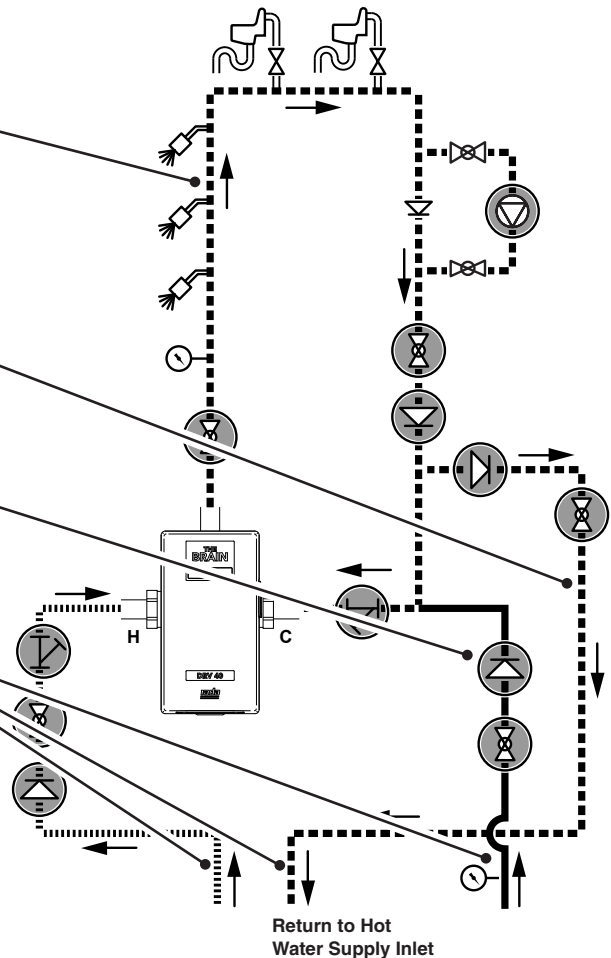

Armstrong International
Parc Industriel Des Hants-Sarts, 2ème Avenue No. 4, Haerstal, B-4040, Belgium
armstronginternational.com/brain

Problem: “Outlet temperature fluctuates more than $\pm 2^{\circ}\text{C}$...”

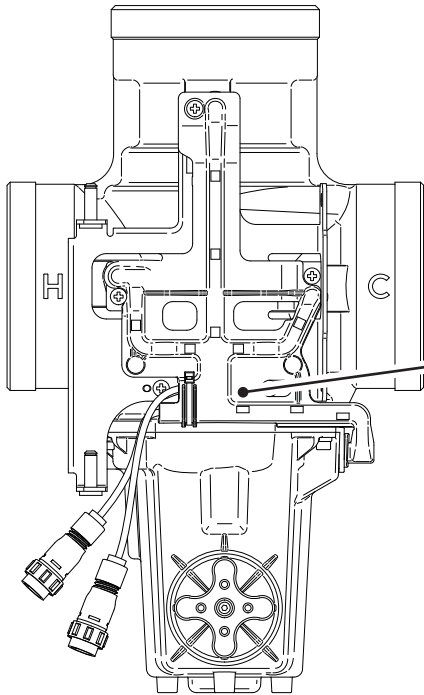

Check internal mechanism
 Mechanism is jamming or slow to control.
 Clean and descale the following parts:

- Proportioning Assembly
- Gear Drive Assembly
- Magnetic Rotor

Renew separator seal and lubricate internal mechanism.

Check blend circuit flow rate.
 Flow rate is less than 10 gpm (37.8 lpm). Reset circuit flow rate and check for the following:

- Air locks
- Blocked strainers
- Closed valves
- Pump failure

Water pressure
 Make sure supply pressures are balanced.
 Check for the following:

- Air locks
- Blocked strainers
- Closed valves

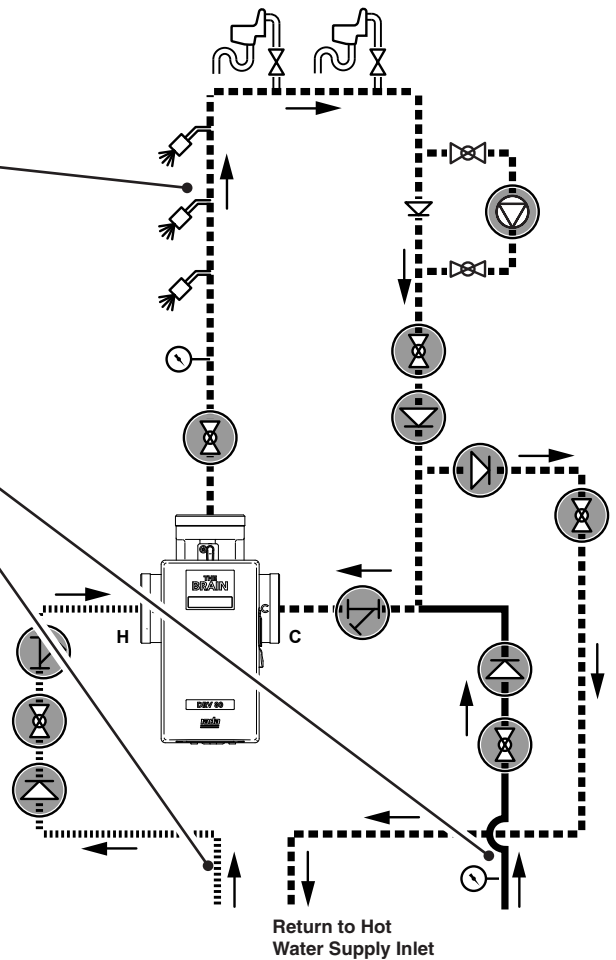

Problem: “LCD Display shows any of the following...”

Temp High 53°C
Setpoint 49°C

Outlet temperature exceeds the **above setpoint** value. This condition causes an alert signal to be activated.

Temp Low 38°C
Setpoint 49°C

Outlet temperature is below the **below setpoint** value. This condition causes an alert signal to be activated.

Temp 49°C
Error Temp 3

Outlet temperature exceeds the Error Temp value. This condition causes the DRV80 to switch to full cold. For the most probable causes and solutions see **DRV80 Display Errors** on page 60.

If any other error message is displayed see **DRV80 Display Errors** on pages 59-61.

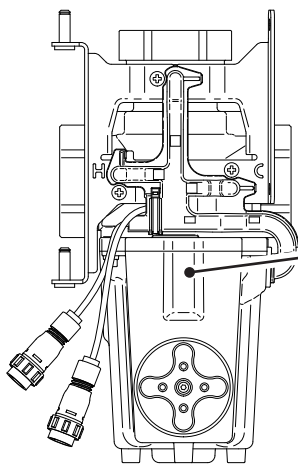

Check internal mechanism
Mechanism is jamming or slow to control.
Clean and descale the following parts:

- Proportioning Assembly
- Gear Drive Assembly
- Magnetic Rotor

Renew separator seal and lubricate internal mechanism using silicone based grease suitable for plumbing applications

Inlet water temperatures
Check water supplies are connected to the correct inlet ports.
Check inlet supply temperature

Reset DRV80
Turn power off for 10 seconds and restart.

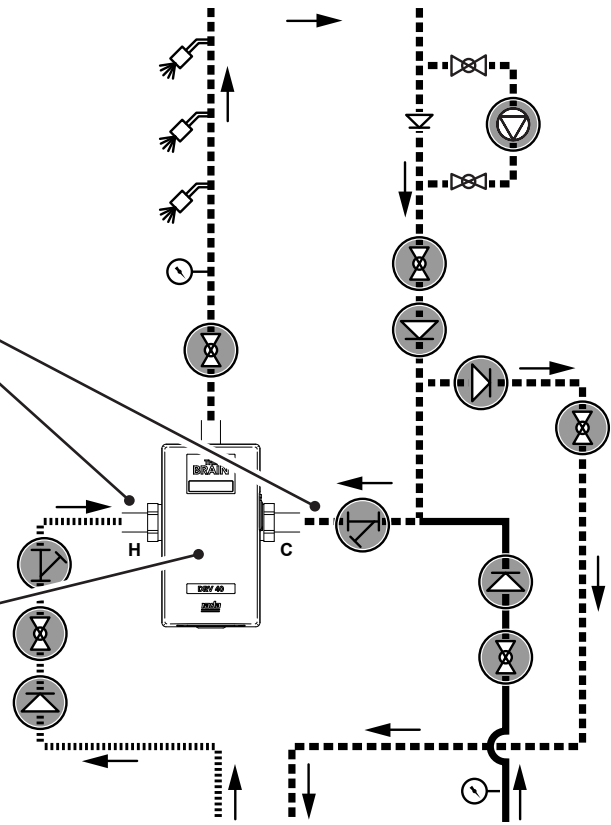

Armstrong International
Parc Industriel Des Hants-Sarts, 2ème Avenue No. 4, Haerstal, B-4040, Belgium
armstronginternational.com/brain

Problem: “Blend circuit does not fully return to normal within the Disinfection Timeout period...”

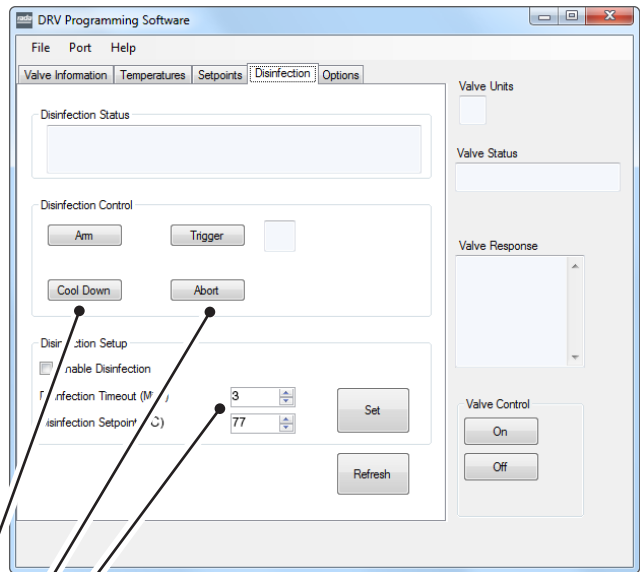

Blend circuit / Control software
 Blend circuit does not fully return to normal temperature within the **Disinfection Timeout** period. Check the following:

- Disinfection Timeout value.
- Cool Down start and finish times.
- Early abort of disinfection cycle.
- Use of a dump valve to speed up cool down time.

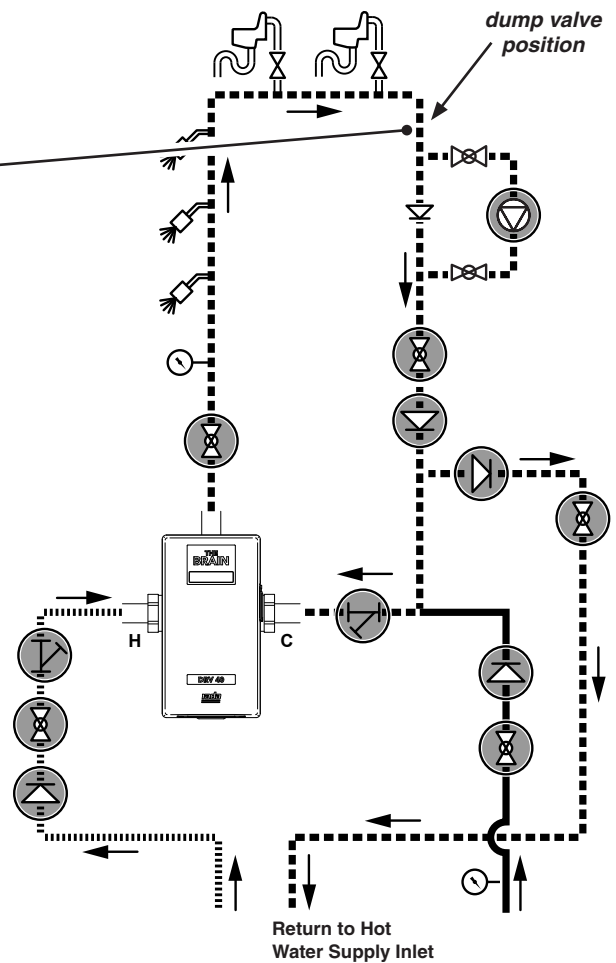

Armstrong International
 Parc Industriel Des Hants-Sarts, 2ème Avenue No. 4, Haerstal, B-4040, Belgium
 armstronginternational.com/brain

Problem: “Constant difference between blend circuit temperature reading and DRV80 temperature display..”

Readings are not equal after outlet temperature has stabilized

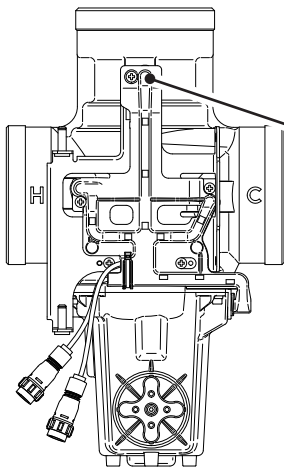
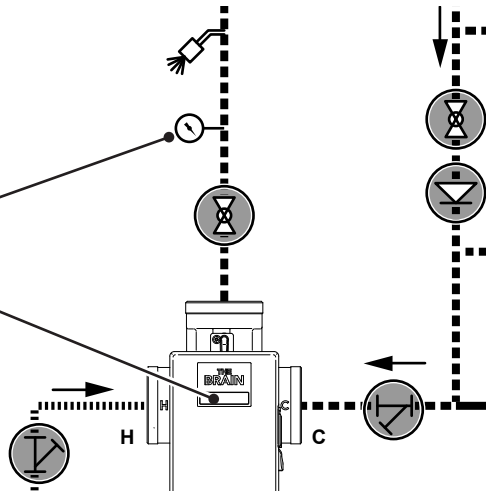

Check outlet thermistor
Turn power off for 10 seconds and restart.
If the error persists, check the thermistor connections or replace the thermistors.

Blend circuit thermometer
Check or replace.

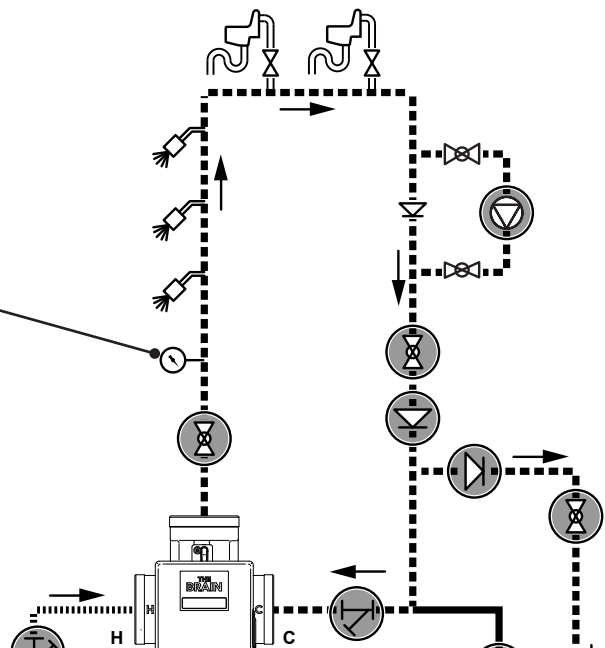

Problem: “Unable to adjust outlet temperature...”

DRV80 display errors

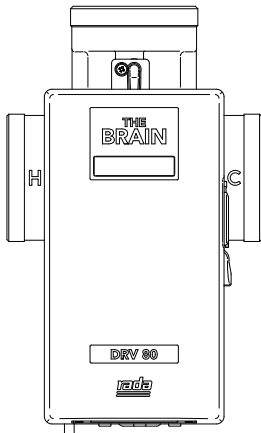

- Temp 49 °C
Error PCB
- Temp 49 °C
Error Drive
- Temp 49 °C
Error Thermistor
- Temp 49 °C
Error Temp

*These are the most likely error messages to be displayed during this problem. For the most probable causes and solutions see **DRV80 Display Errors** on page 59-60.*

*If any other error message is displayed see **DRV80 Display Errors** on pages 59-61.*

Check blend circuit flow rate.

Flow rate is less than 38 l/m. Reset circuit flow rate and check for the following:

- Air locks
- Blocked strainers
- Closed valves
- Pump failure

Check mixed return temperature.

Minimum recirculation loop temperature loss = 1°C

Check valves

*Check circuit to make sure checkvalves are correct positioned and operating normally. (See **Piping Diagrams** on pages 12-15)*

Water pressure / flow

Make sure supply pressures are balanced. Make sure mixed return is flowing correctly to water heater. Check for the following:

- Air locks
- Blocked strainers
- Closed valves

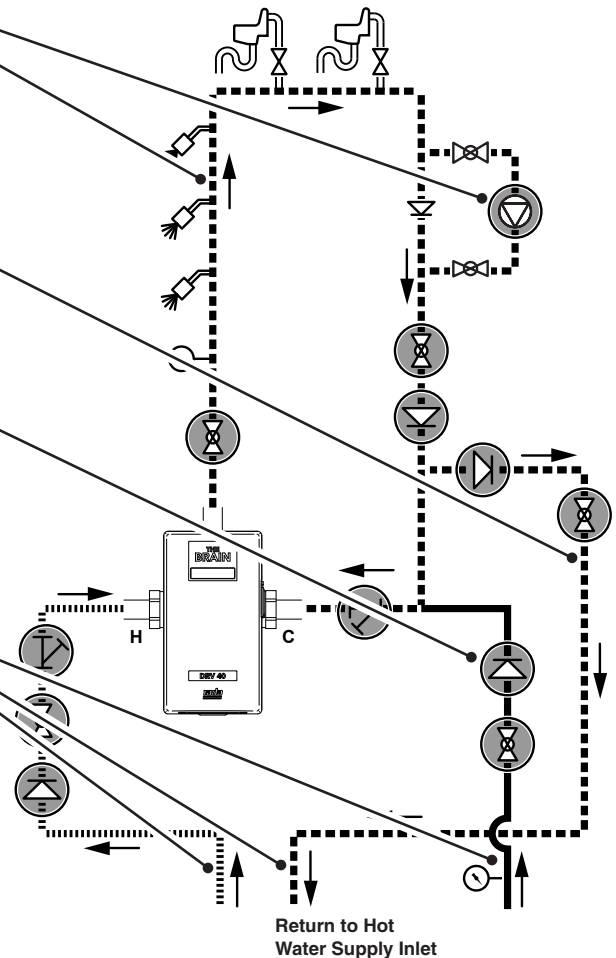

Armstrong International
 Parc Industriel Des Hants-Sarts, 2ème Avenue No. 4, Haerstal, B-4040, Belgium
armstronginternational.com/brain

Problem: “No display...”

DRV80 display errors

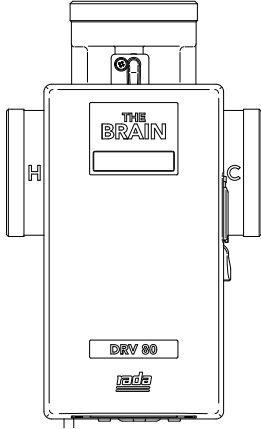

A technical drawing of the DRV80 device, a rectangular unit with a top-mounted component. The front panel features a display screen at the top, the text "THE BRAIN" below it, and a "DRV 80" label at the bottom. The "ada" logo is visible at the very bottom. To the right of the device is a solid blue rectangle representing a blank display.

*Blank display.
For the most probable causes and solutions see **DRV80 Display Errors** on page 61.*

*If any other error message is displayed see **DRV80 Display Errors** on pages 59-61*

Problem: “No display or no control...”

DRV80 display errors

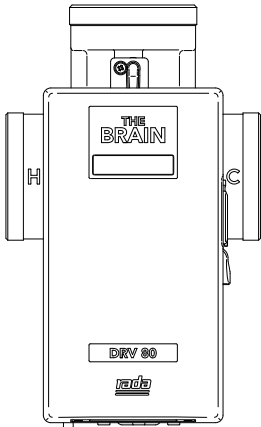

A technical drawing of the DRV80 device, similar to the one above. To its right, a blue rectangle represents the display showing two error messages: "Temp 49°C" and "Error PCB".

*These are the most likely error messages to be displayed during this problem. For the most probable causes and solutions see **DRV80 Display Errors** on pages 59-61.*

*If any other error message is displayed see **DRV80 Display Errors** on pages 59-61.*



Problem: “Cannot read the LCD display...”

DRV80 display errors

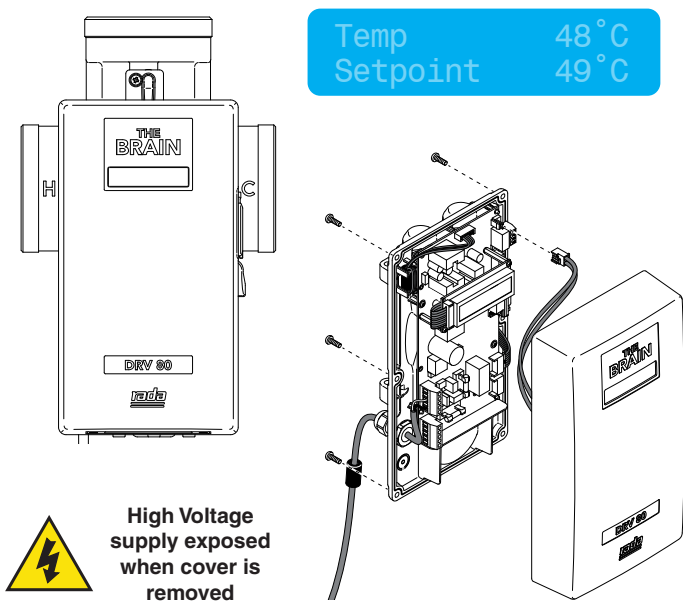

Temp 48 °C
Setpoint 49 °C

High Voltage supply exposed when cover is removed

Isolate power to the DRV80 **before** disconnecting and removing the Electronics Module, see pages 43-46. Adjust the brightness setting on the PCB and reconnect the Electronics Module.

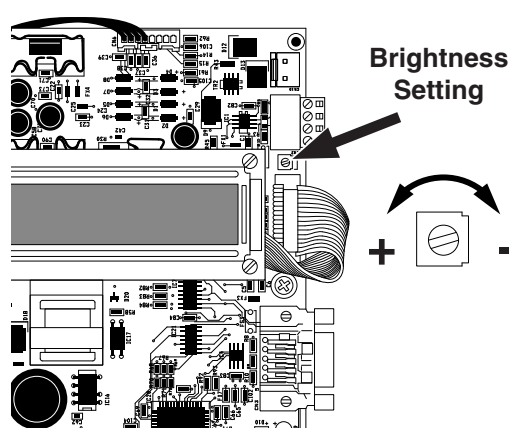

Brightness Setting

+

-

If any other error message is displayed see **DRV80 Display Errors** on page 59 - 61.



Problem: “High pitched noise from DRV80...”

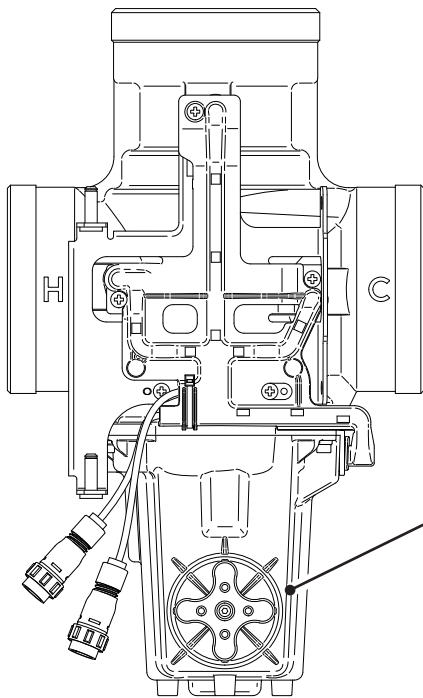

Check motor

Motor may be worn, replace.

Water pressure

Make sure supply pressures are balanced. Check for the following:

- Air locks
- Blocked strainers
- Closed isolator valves
- Check inlet flow rates are within specified parameters. See **Specifications** on page 8.

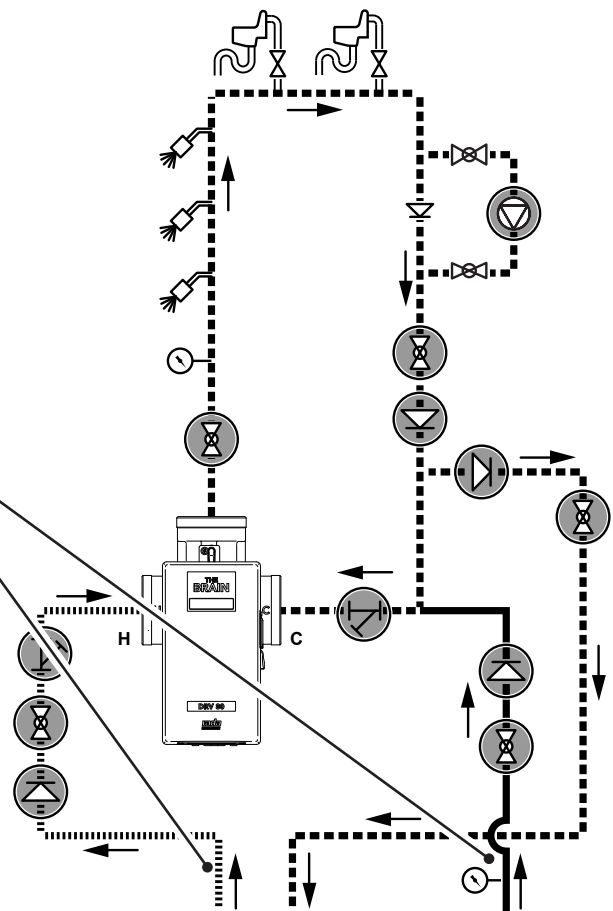

Armstrong International
 Parc Industriel Des Hants-Sarts, 2ème Avenue No. 4, Haerstal, B-4040, Belgium
armstronginternational.com/brain

Problem: “Water leaking from DRV80...”

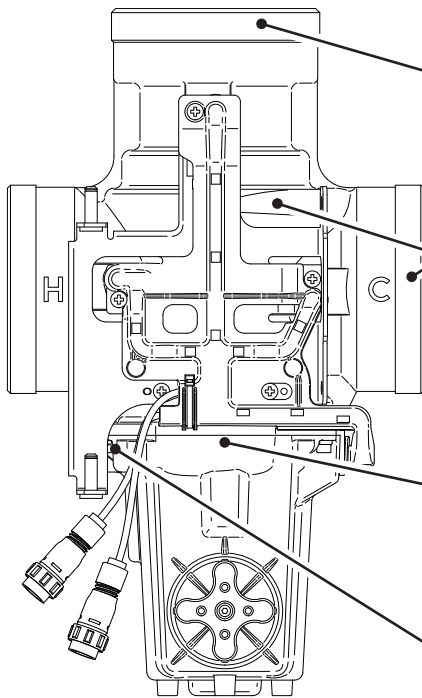

Check inlet and outlet connections
Check inlet and outlet thread joints. Check a correct seal has been made with PTFE thread sealing tape or liquid sealant. Oil-based, non-setting joint compounds should not be used.

DRV body failure
DRV80 replacement required.

Check all DRV seals
Check all internal seals for wear and / or damage. Clean and refit seals. If problem persists, replace seals. Only use silicone based lubricants on rubber seals in cartridge (see page 53).

Check drain plug
Check drain plug and seal for wear and / or damage. Make sure drain plug and seal are fitted and tightened adequately. If problem persists, replace both plug and seal.



Limited Warranty and Remedy

Armstrong Hot Water, Inc. (“Armstrong”) warrants to the original user of those products supplied by it and used in the service and in the manner for which they are intended, that such products shall be free from defects in material and workmanship for a period of one (1) year from the date of installation, but not longer than 15 months from the date of shipment from the factory [unless a Special Warranty Period applies, as listed below]. This warranty does not extend to any product that has been subject to misuse, neglect, or alteration after shipment from the Armstrong factory. Except as may be expressly provided in a written agreement between Armstrong and the user, which is signed by both parties, Armstrong **DOES NOT MAKE ANY OTHER REPRESENTATIONS OR WARRANTIES, EXPRESS OR IMPLIED, INCLUDING, BUT NOT LIMITED TO, ANY IMPLIED WARRANTY OF MERCHANTABILITY OR ANY IMPLIED WARRANTY OF FITNESS FOR A PARTICULAR PURPOSE.**

The sole and exclusive remedy with respect to the above limited warranty or with respect to any other claim relating to the products or to defects or any condition or use of the products supplied by Armstrong, however caused, and whether such claim is based upon warranty, contract, negligence, strict liability, or any other basis or theory, is limited to Armstrong’s repair or replacement of the part or product, excluding any labor or any other cost to remove or install said part or product, or, at Armstrong’s option, to repayment of the purchase price. As a condition of enforcing any rights or remedies relating to Armstrong products, notice of any warranty or other claim relating to the products must be given in writing to Armstrong: (i) within 30 days of last day of the applicable warranty period, or (ii) within 30 days of the date of the manifestation of the condition or occurrence giving rise to the claim, whichever is earlier. **IN NO EVENT SHALL ARMSTRONG BE LIABLE FOR SPECIAL, DIRECT, INDIRECT, INCIDENTAL OR CONSEQUENTIAL DAMAGES, INCLUDING, BUT NOT LIMITED TO, LOSS OF USE OR PROFITS OR INTERRUPTION OF BUSINESS.** The Limited Warranty and Remedy terms herein apply notwithstanding any contrary terms in any purchase order or form submitted or issued by any user, purchaser, or third party and all such contrary terms shall be deemed rejected by Armstrong.

Special Warranty Periods are as follows:

The Brain - Model DRV80 shall have a 5-year parts warranty on all components other than preventative maintenance service items, mentioned on page 42, which includes batteries and all ‘wetted’ O-rings / Seals.

© 2016 Armstrong International, Inc.

Designs, materials, weights, performance ratings and prices are subject to change without notice.



Armstrong International
Parc Industriel Des Hants-Sarts, 2ème Avenue No. 4, Haerstal, B-4040, Belgium
armstronginternational.com/brain

IOM-1079-K2-B Kohler Mira Limited, April 2016