

Guide to The Brain[®] Modbus Networking Installation and Operation Manual

IOM-776



Guide to The Brain[®] Modbus Networking

Contents

Introduction	3
The Brain [®] Electronics Overview	4
Connecting to the Modbus port	6
The Brain [®] functional overview.....	8
The RTU format and registers relevant to the Brain [®]	9
Enumeration Details.....	13
The Brain [®] Programming Sequence	13
Enabling Disinfection Feature	14
Triggering Disinfection Sequence	14
Stopping Disinfection	14



Introduction

Modbus is a well established protocol that is commonly used and ideally suited for connecting multiple devices in a commercial/institutional or industrial environment. This is largely because of its resilience when it comes to electrical interference. The Brain's® interface is designed for serial communications protocols, but can be configured to communicate with a BAS (Building Automation System) using Modbus protocols. When configured for Modbus, the Brain® acts as an RTU (Remote Terminal Unit) that is monitored by the BAS.

The following is a guide for connecting the Brain® (DRV40/DRV80) to a BAS using a Modbus RTU protocol. Please review the appropriate Brain® Installation and Maintenance guide available at www.armstronginternational.com/brain to familiarize yourself with the product specification and installation before attempting to connect the BAS.

The Brain® Electronics Overview

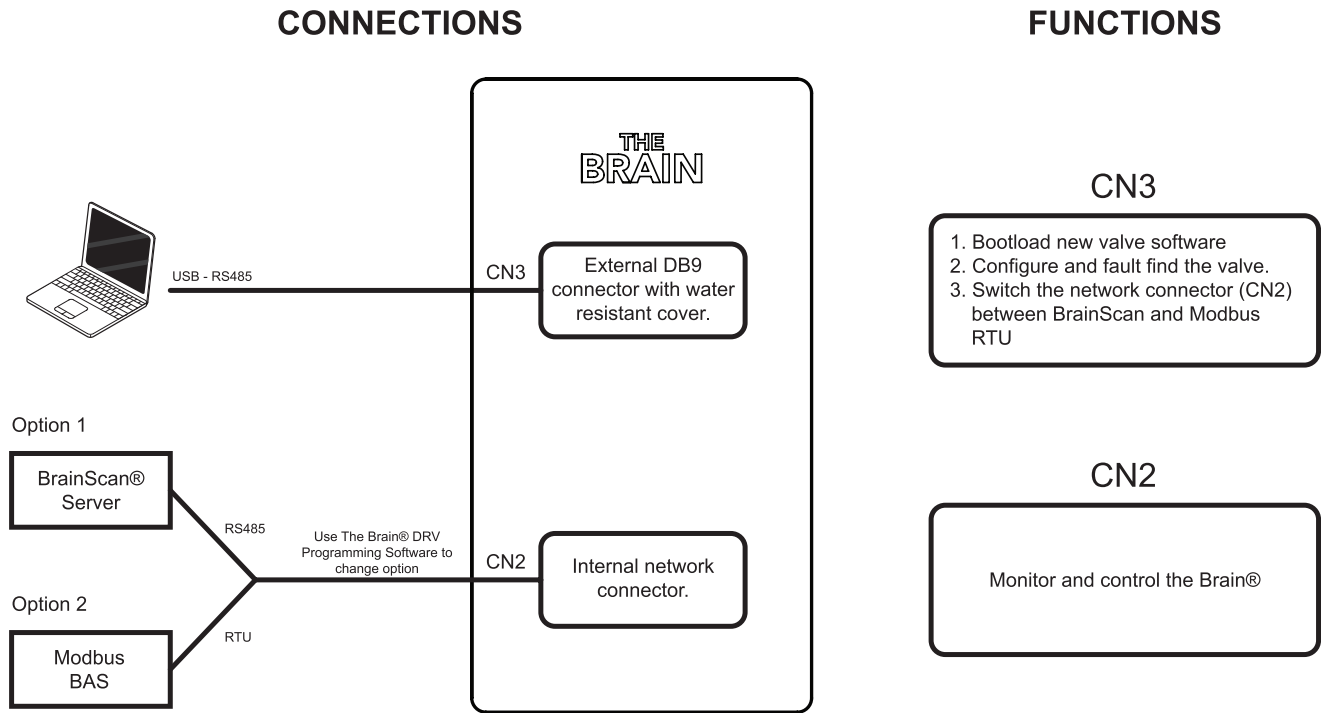

Figure 1: Functional diagram of the Brain Electronics Enclosure

CN3 is the DB9 or external debug port which can be accessed by removing the rubber plug on the side of the module.

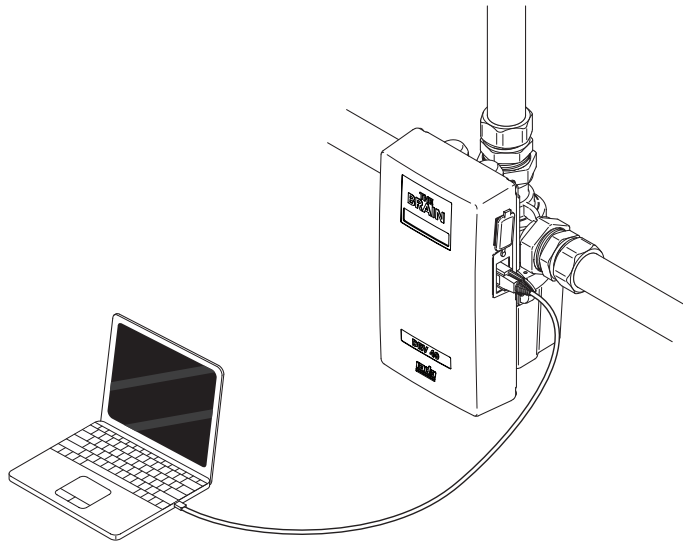

Figure 2

This connection can be used for:

1. Setup, calibration, debug and diagnostics by connecting a laptop via the USB to RS485 cable and running the Brain® DRV Programming Software (available at www.armstronginternational.com/brain). This software is also used to switch the internal network connector (CN2) over from BrainScan® to Modbus and then set a unique network address for the valve. It can also be used to switch CN2 back to BrainScan® if required.
2. Reprogramming can also be done via this port if the laptop has the latest Bootloader software installed.

CN2 is the internal network connection for the Brain®. CN2 also uses RS485, but with the option of running either the BrainScan® protocol or Modbus RTU protocol.



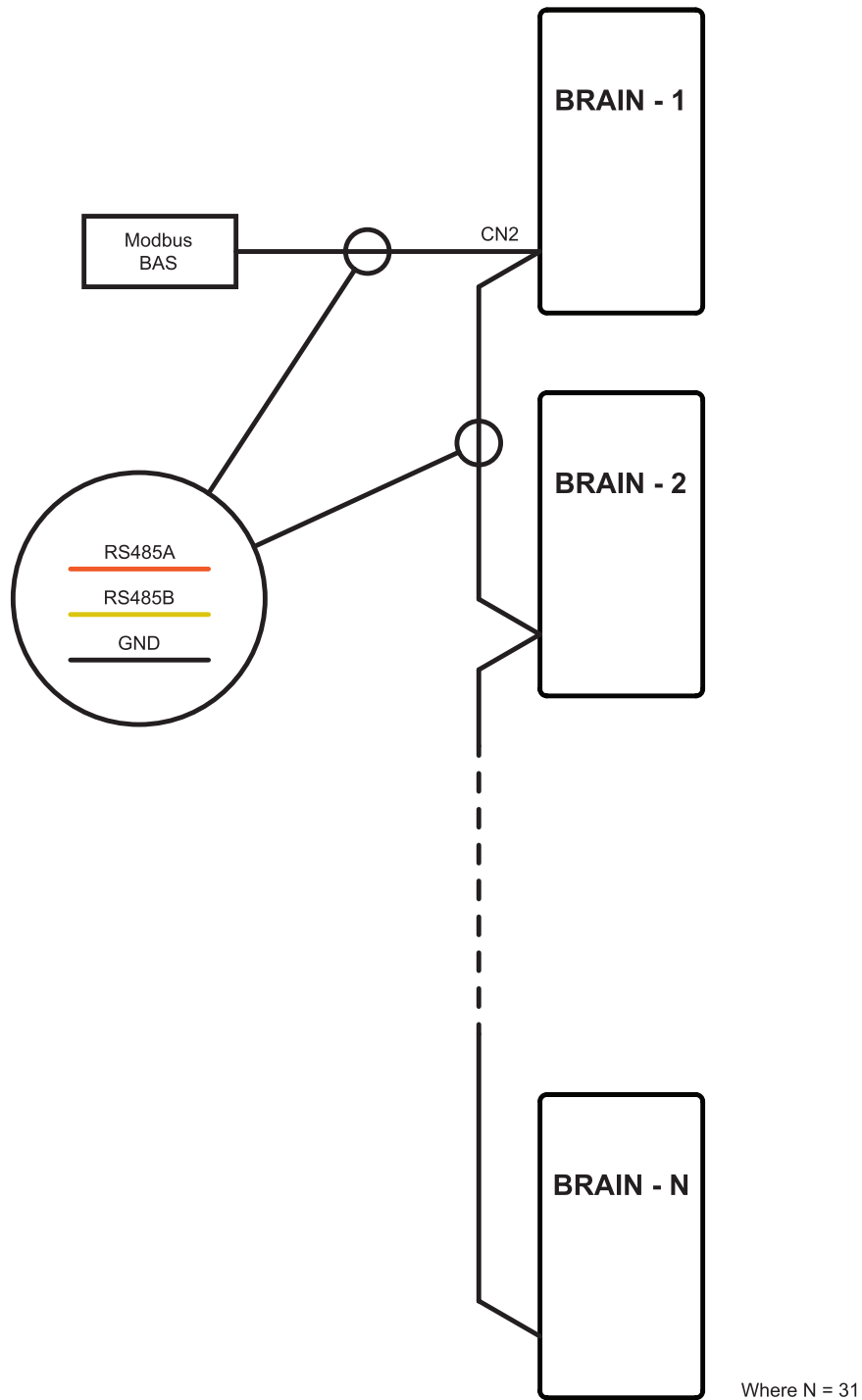

Figure 1: Functional diagram of the Brain Electronics Enclosure

Figure 3 illustrates how a Brain® Modbus network should be arranged. The DRV Programming Software should be used first to set the valve to its unique address via CN3 connector. This should be done before the network is activated (or before each Brain® is connected to the network).

The cable connecting to the BAS should be twisted pair CAT 5 and should be in a “daisy chain” arrangement as shown, rather than connecting them in star formation (all Brains® to one single point).

Connecting to the Modbus port



WARNING! There are high voltages present on the control PCB. Ensure that the power supply to the Brain® has been isolated and that the unit has fully powered down before removing the cover to access the network port.

CN2 Connectivity is as follows:

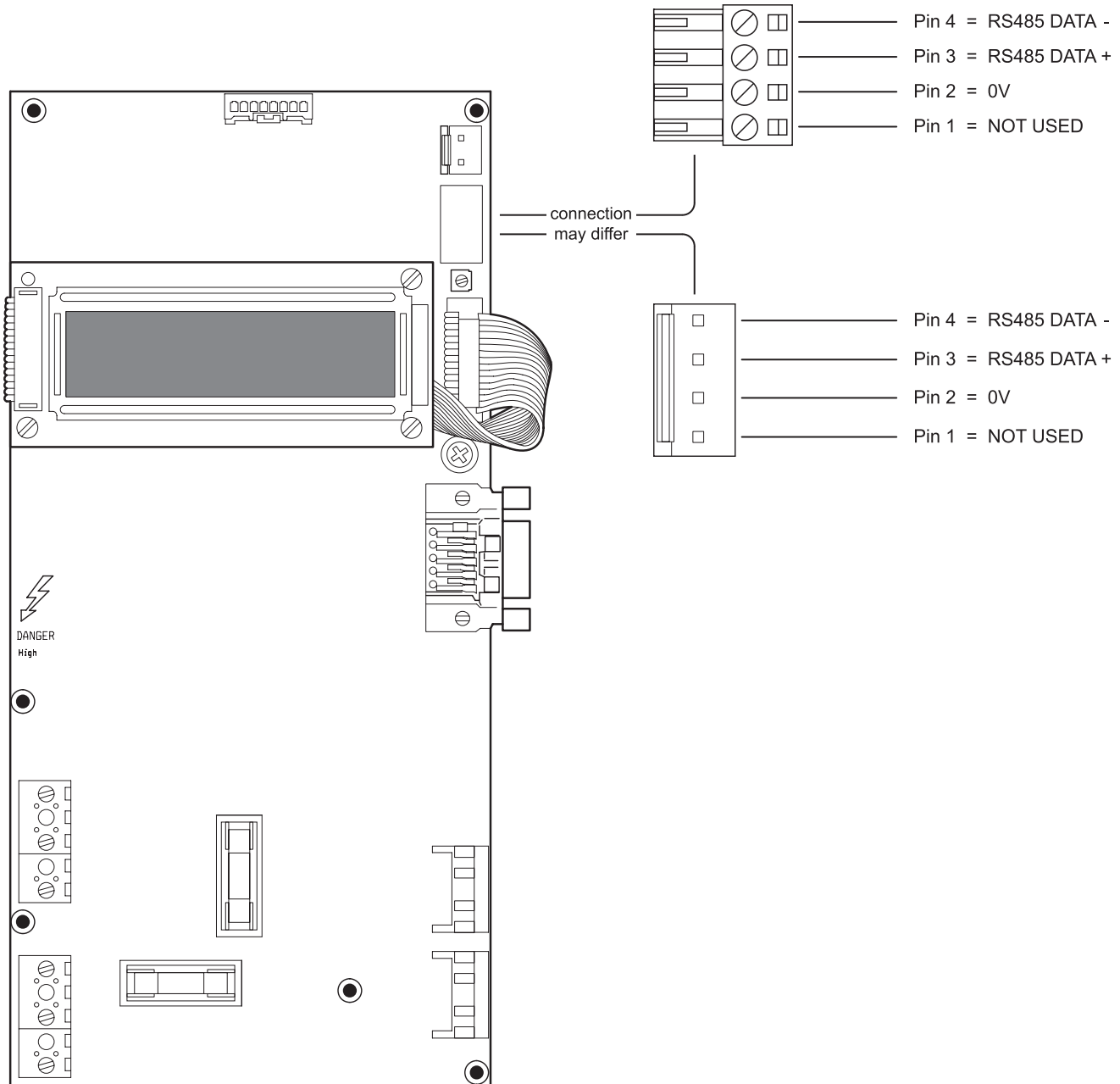

Figure 4: BrainScan® / Modbus connector pinout



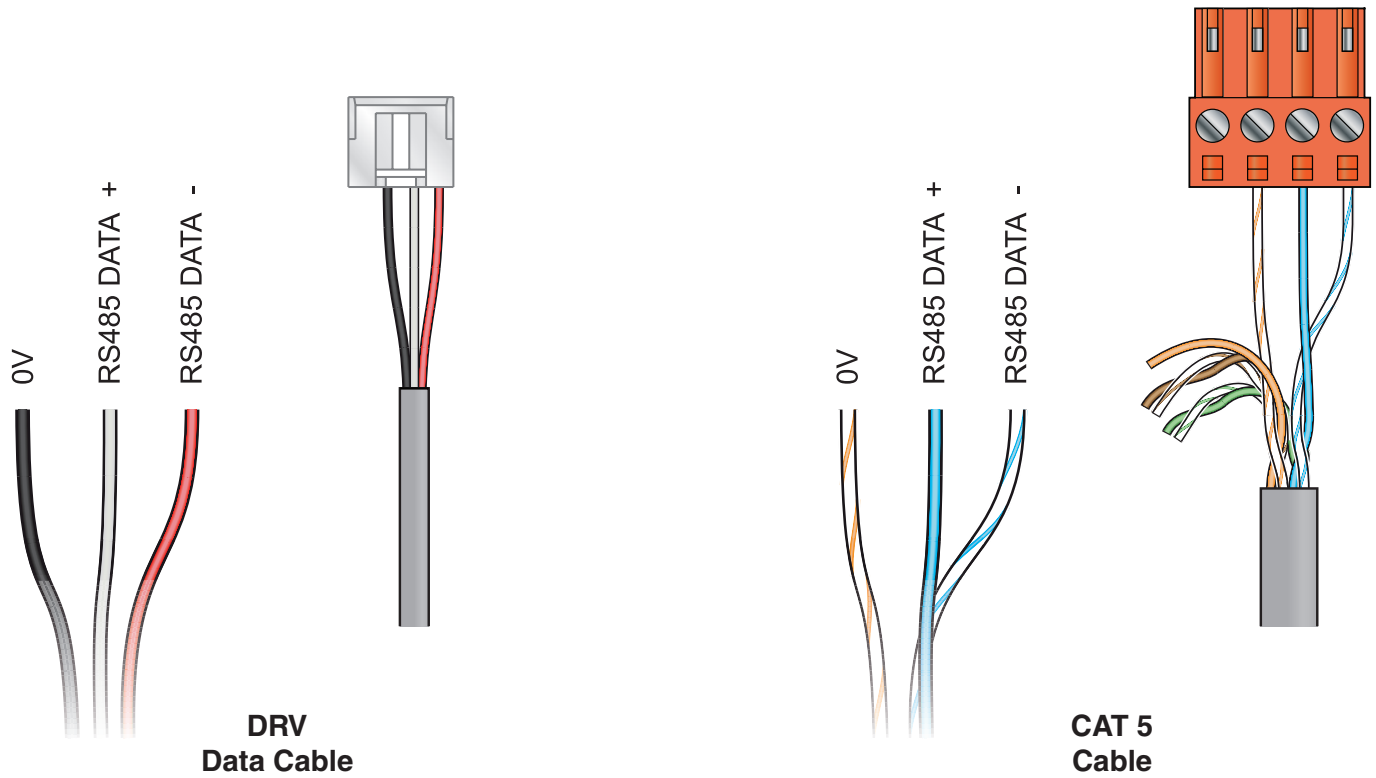

Figure 5: Recommended cable arrangement.

Figure 5 shows the connection for the DRV Data Cable or a CAT 5 cable (depending upon the connector type of the DRV). The twisted pair CAT 5 cable is arranged to minimise any signal interference.

The Brain[®] functional overview

The Brain[®] is a micro-processor controlled recirculation valve specifically designed to be used in warm water systems. Hot and cold water is mixed to produce blended water at a setpoint stored in the configuration software of the valve.

In order to do this effectively it has 3 temperature sensors that constantly monitor the hot inlet, cold inlet and outlet (blended) temperatures. The Brain[®] is designed to maintain the water temperature automatically at the chosen setpoint however, for safety; provision is made to generate various alert and error conditions should the outlet temperature fall outside certain operating parameters:

High / Low Temperature Alerts

Should the outlet temperature increase or decrease to outside the setpoint range, an alert condition will be shown on the Brain's[®] display. There is also the option to trigger a relay which can be linked to an auxiliary alarm. The valve will continue to operate normally during an alert condition.

Error Temperature

Should the outlet temperature exceed this threshold, an error condition will be shown on the Brain's display. An error condition will also trigger a relay which can be linked to an auxiliary alarm. For safety, the Brain[®] will drive to the full cold position and remain there until the power is cycled off / on.

Disinfection

The Brain[®] has a disinfection feature which can be used to run full hot water to all outlets in order to clear bacteria from the plumbing system (and the outlet fittings as required). To use the disinfection feature certain parameters must be defined and set within the Brain's[®] software. For a remote monitoring system (BAS), this involves writing a specific set of registers in the correct sequence. This is described in the section 'Correct Brain[®] Disinfection Sequence'.



The RTU format and registers relevant to the Brain®

The BMS software will need to be using Modbus RTU (Remote Terminal Unit) format in order to communicate with the Brain®.

START	ADDRESS	FUNCTION	DATA	CRC	END
3.5 Ch idle	8 bits	8 bits	N x 8 bits	16 bits	3.5 Ch idle
At least 3.5 character times of silence (MARK condition)	Station (RTU) Address	Function codes (E.g. Read coils / inputs)	Message data (length will depend on message type)	Error check	At least 3.5 character times of silence between frames

Figure 6: Modbus RTU format

1. Communications Standard
 - 1.1. Baud Rate 9600
 - 1.2. Parity None
 - 1.3. Data bits 8
 - 1.4. Stop Bits 1
 - 1.5. Mode RTU
 - 1.6. Electrical Interface RS485 3w cabling no pull-up
2. Modbus functions supported
 - 2.1. Read holding registers (0x03)
 - 2.2. Write Single register (0x06)
 - 2.3. Write Multiple registers (0x10)
 - 2.4. Read File record (0x14) (File number 1 Duty flush Record)
3. Modbus error codes
 - 3.1. Illegal Address
Returned if the read or write register address is outside the address range of the unit
 - 3.2. Illegal data
Returned if data written to a register is outside the bounds for that register or the valve is not configured to accept such data
 - 3.3. Slave failure
Returned if the valve attached to the adapter cannot be identified
4. Data Description General
The unit data is divided as follows
 - 4.1. Prime data section (registers 1 to 19).
This is active data and represents the actual status of the valve
 - 4.2. Configuration and log data (registers 20 – 305)
This data is typically stored in non volatile storage within the valve or adapter. Configuration data is used to control valve and unit operations. The log data is stored data for various units operation.
 - 4.3. Commands. (Registers 306 – 310)
Logic command used to force the valve into certain special functions.
 - 4.4. Comments
 - 4.5. The Brain® acts as the Modbus slave unit or RTU and keeps its registers synchronised with the Brain's® internal database. This synchronisation is scheduled every 24 milliseconds. Following a successful write to the Brain® RTU from the Modbus master, the Brain's® database is updated with the new register values. This is again on a 24 milliseconds schedule. However, at least 5 seconds should be allowed between Modbus writes and updates. This is because the Brain® may need to perform mechanical movement and other setup changes in response to the update.

Table 1: Modbus Registers for the Brain®

Reg	Description	Number of Registers	Units	Read / Write
0	Unit address	1	Address 1-31	R O
1	Setpoint temperature	1	0.1 Deg C	R / W
2				
4	Valve Status	1	Enumeration 1 (see 4.5.1)	R / W
5				
6	Valve outlet temperature	1	0.1 Deg C	R O
7	Valve remaining time	1	Seconds	R O
8	Valve error code	1	Enumeration 9 (see 4.5.2)	R O
9				
10	Hot Inlet Temperature	1	0.1 Deg C	R / W
11	Cold Inlet Temperature	1	0.1 Deg C	R / W
106	Valve serial number	2	Serial Number	R O
107				
108	Date & time of manufacture	2	date/time(long)	R O
109				
110	Valve Firmware type number	1	integer	R O
111	Valve Firmware version number	1	integer	R O
112	Valve configuration identity	1	integer	R O
113	Valve configuration version	1	integer	R O
114	Adapter Firmware version number	1	date/time(long)	R O
115	Adapter configuration identity	1	integer	R O
116	Date & time of valve commissioning	2	date/time(long)	R / W
121	Number of valve operations	2	number (long)	R O
122				
123	Total valve ON time	2	minutes	R O
124				
125	Date & time of valve service	2	date/time(long)	R / W
126				
127	ID of valve service engineer	1	number integer	R / W
128	Hours valve has been unused	1	Hours	R O
129	Reserved			
139	Valve Identity	16	String (Packed 2 chars to 1 register)	R / W
155	Hours since last disinfection	1	hours	R O
156	Disinfection time & date	2	date/time(long)	R O
158	User ID disinfection	1	integer	R / W
159	Disinfection confirmation	1	Logic	R O

Table 1: Modbus Registers for the Brain® Continued

Reg	Description	Number of Registers	Units	Read / Write
306	Arm disinfection command	1	Command	R / W
307	Trigger disinfection command	1	Command	R / W
308	Abort disinfection command	1	Command	R / W
314	Disinfection Cool Down	1	Command	R / W
400	DRV Series Serial Line Address	1	0 = Standard 1 = Alternate	R / W
401	Disinfection enable	1	Logic 1 = On 0 = Off	R / W
402	Disinfection Timeout	1	Minutes	R / W
403	High Alert	1	0.1 Deg C	R / W
404	Low Alert	1	0.1 Deg C	R / W
405	Error Temperature	1	0.1 Deg C	R / W
406	Relay Active (set relay to active on High / Low Alerts, instead of just Temp Error)	1	Logic 1 = On 0 = Off	R / W
407	Offset Temperature	1	0.1 Deg C	R / W
408	Valve's temperature units (degrees C or F)	1	0 = Deg F 1 = Deg C	R / W
409	DRV Maximum Setpoint	1	0.1 Deg C	R / W
410	DRV Minimum Setpoint	1	0.1 Deg C	R / W
411	DRV Default Setpoint	1	0.1 Deg C	R / W
412	DRV spare / remote thermistor 1	1	0.1 Deg C	R O
413	DRV spare / remote thermistor 2	1	0.1 Deg C	R O

Note! In order to change reg 400-413, the valve status (reg 4) must be set to the OFF position

Enumeration Details

4.5.1. Enumeration 1

- 0 = OFF
- 1 = ON
- 2 = FULL COLD
- 3 = PAUSE
- 4 = DUTY FLUSH
- 5 = COMMISSIONING
- 6 = DISINFECTION
- 7 = ERROR
- 8 = FORCED DISABLE

4.5.2. Enumeration 9

- 0 = NO ERROR
- 1 = OVER TEMPERATURE
- 2 = STUCK MOTOR
- 3 = MOTOR CALIBRATION
- 4 = VALVE FAILURE
- 5 = THERMISTOR FAILURE
- 6 = UNCONFIGURED
- 7 = A TO D ERROR
- 8 = RAM ERROR
- 9 = EE ERROR
- 10 = FLASH ERROR
- 11 = ALGORITHM ERROR
- 12 = CONTROLLER ERROR
- 13 = BATTERY ERROR
- 14 = SCHEDULER ERROR

The Brain[®] Programming Sequence

Set **Reg 4** to **OFF** before adjusting any of the following registers:

Reg 400-413

Set **Reg 4** back to **ON**

All other registers can be set without setting **Reg 4** to **OFF**.

IMPORTANT!

The disinfection feature has a specific sequence as all Alerts and Errors are disabled temporarily while hot water is flushed through the DRV. Please read the following section on setting up the disinfection sequence carefully.

The Brain's[®] disinfection feature is a manual process and for safety reasons must be monitored constantly.



Enabling Disinfection Feature

In order to enable the Disinfection feature for use, the following registers must be set up when the Brain[®] is configured:

Reg 401 Set to enable the disinfection feature to be used.

Reg 402 Disinfection Timeout in minutes (max 1800).

The Disinfection Timeout is the number of minutes the temperature alert and error displays are disabled to allow for disinfection and cool down of the blend circuit before switching back to automatically. (See **The Brain[®] DRV40 or DRV80 product manual** for full details of disinfection and how to determine a reliable Disinfection Timeout period.)

Triggering Disinfection Sequence

Each time a disinfection cycle is to be run the following sequence must be used:

1. **Reg 306** To **Arm** the disinfection cycle (set to 1)
2. **Reg 307** To **Trigger** the disinfection cycle (set to 1 within 30 seconds else Brain[®] will clear **Arm** status)

Stopping Disinfection

Reg 314 Cool Down (normally be used to end the sequence – this will switch the Brain[®] to the full cold position to allow the temperature of the blend circuit to be reduced to a safe level)

Reg 308 Abort (Must be able to activate at any stage of the sequence. Emergency stop, Brain[®] immediately re-enables temperature alert and error displays. If the cycle is at full hot, the Brain[®] switches to full cold and displays Error Temp. Cycle the power off / on to reset the Brain[®], make sure the blend circuit is at a safe temperature before allowing any outlets to be used.)

Any attempt to write to registers **401, 306, or 307** in the wrong sequence will result in an error response from the Brain[®].



Notes



Armstrong Hot Water Group

221 Armstrong Blvd., Three Rivers, Michigan, 49093 – USA Phone: (269) 279-3602 Fax: (269) 279-3130

armstronginternational.com