



Sense™ Digital Mixing Valve Installation, Operation and Maintenance (IOM)

This Sense™ Digital Mixing Valve (DMV) has been supplied for this application based upon information provided to Armstrong at the time the order was placed.

This Sense™ DMV is configured for installation in a single Point of Use-Lavatory, Shower, Bath Tub or combination Bath/Shower application depending upon the model selected.

This IOM includes Installation, Operation and Maintenance guidance for the four individual models and the model specific to this installation is listed below along with its serial number.

For Technical Support please call Toll Free: 1-888-468-4673

Recording the serial number and maintaining this IOM on file is strongly recommended.

Model No _____

Serial No _____

Ship Date _____



Introduction

Sense™ features Rada Technology, Rada Sense is a registered trademark of Kohler-Mira Ltd of Cheltenham, England.

Sense™ is a brand of patented Point of Use Digital Mixing Valves (DMV) with a surface mount no-touch control panel for flow and temperature control. Programmable functions include timed flow, service/standby flush and thermal disinfection.

Sense™ is field programmable with download software from Armstrong International web site, armstronginternational.com/files/products/wheaters/sense_laptop_software.zip. An infrared device is needed to communicate between the Rada Sense and your computer.

Safety Warnings

The function of this DMV is to deliver water consistently at a pre-selected temperature directly to a point of use for hand washing, showering and/or bathing applications.

This requires that:

1. It is installed, commissioned, operated and maintained in accordance with the recommendations given in this Manual.
2. Periodic attention is given, as necessary, to maintain the product in good functional order. Recommended guide lines are noted under **SCHEDULED MAINTENANCE** on page 21.
3. Using this product outside the specification limits given in this Manual is not recommended and may present potential risk to users.
4. The electrical connection must be performed by a licensed electrician and comply to all applicable local, state and national electric codes.

General Advisory

The use of the word 'fail-safe' to describe the function of any mixing valve is both incorrect and misleading. This electronic valve incorporates additional shut-off devices to improve the level of safety however, just as in every other mechanism it cannot be considered to be functionally absolutely reliable.

Where chlorine disinfection is performed, DO NOT exceed a chlorine concentration of 50 mg/l (ppm) in water, per one hour exposure time. Such procedures must be conducted strictly in accordance with the information supplied with the disinfectant and with all of the relevant Guidelines/Approved Codes of Practice.

Models

This IOM covers the Sense™ models listed below.

DMV 1 Concealed DMV with a surface mount no-touch control panel for **lavatory** flow and temperature control. Programmable functions include timed flow, service/stand by flush and thermal disinfection.

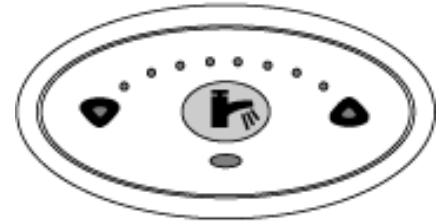

DMV 2 Concealed DMV with a surface mount no-touch control panel for **individual shower** flow and temperature control. Programmable functions include timed flow, service/stand by flush and thermal disinfection.

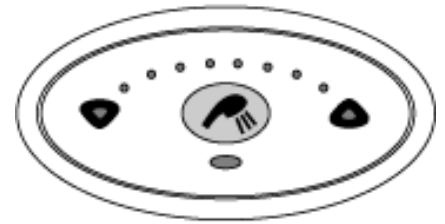

DMV 3 Concealed DMV with a surface mount no-touch control panel for **individual bath** fill flow and temperature control. Programmable functions include timed flow, service/stand by flush and thermal disinfection.

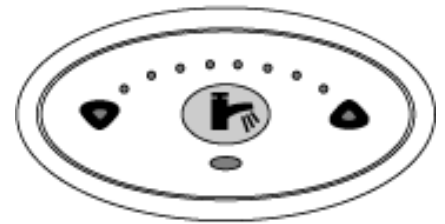

DMV 23 Concealed DMV with a surface mount no-touch control panel for **combination bath and shower** flow and temperature control. Programmable functions include timed flow, service/stand by flush and thermal disinfection.

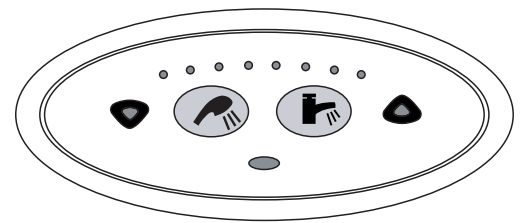

Important Note

Sense™ is supplied as standard with a factory preset flow time, a default set point (on) temperature, a user adjustable temperature selection range and a maximum temperature limit stop. These settings are site adjustable and the service flush and thermal disinfection modes can be initialized with programmable software. Go to armstronginternational.com/files/products/wheaters/sense_laptop_software.zip for programming software.

The programmer software has a separate IOM.

Water Temperature Control - Single Point of Use

Digital

Sense™ Model DMV1

Concealed digital mixing valve with surface mount control panel for lavatory flow and +/-2°F (+/-1°C) temperature control.

Operational Specifications

- Programmable timed flow
- No touch on/off flow control
- No touch temperature adjustment
- Programmable minimum/maximum temperature access limits
- Programmable service flush
- Programmable thermal disinfection mode
- Data logging capabilities



For a submittal drawing, refer to D34255.

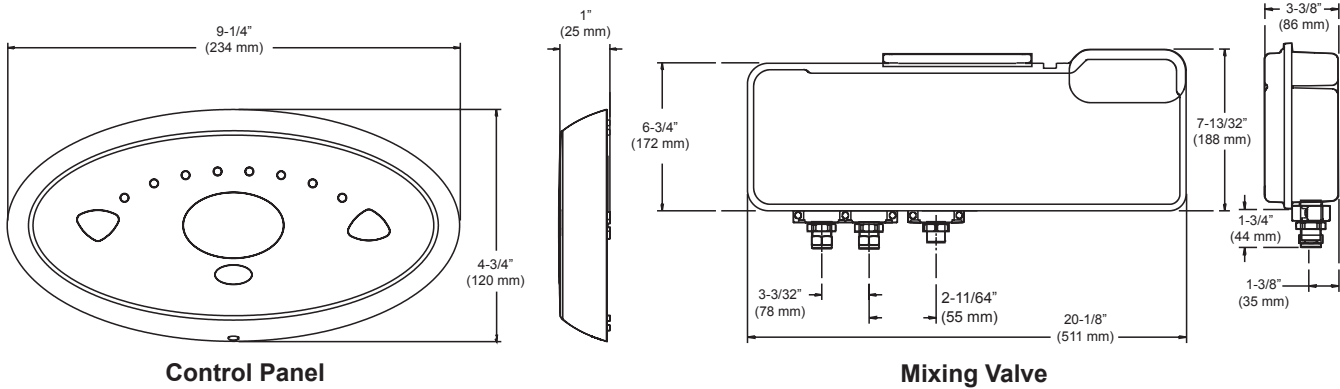
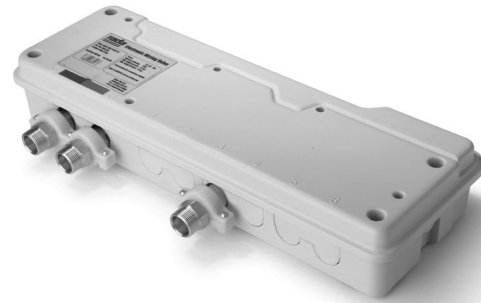

Sense™ Digital Mixing Valves												
Model	Pressure Drop (psi)										Min. Flow	Cv
	5	10	15	20	25	30	35	40	45	50		
DMV1	3	4	5	6	6	7	7	8	9	9	1	1.2
DMV2	6	8	10	11	12	14	15	16	17	18	1.6	2.5
DMV3												
DMV23												

Water Temperature Control - Single Point of Use

Digital

Sense™ Model DMV1-Lavatory Technical Specifications

Connections

- Inlet and outlet connections: 1/2" NPT

Materials

- Control panel cover: Chrome ABS I
- Mixing unit enclosure: PC/ABS
- Integral components: DZR brass stainless steel and engineering plastic

Temperatures

- Factory pre-set:
 - Min 86°F (30°C), Max 106°F (41°C)
 - Default 100°F (38°C)
- Programmable range:
 - Min 86°F - 117°F (30°C - 47°C),
 - Max 91°F - 122°F (33°C - 50°C),
 - Default 86°F - 122°F (30°C - 50°C)
 - Full cold can also be selected
- Minimum blend temperature differential from hot supply:
 - 5°F (2°C)
- Optimum thermostatic control range:
 - 86°F - 122°F (30°C - 50°C)
- Inlet Cold water range (recommended):
 - 34°F - 68°F (1°C - 20°C)
- Inlet Hot water range (recommended):
 - 122°F - 149°F (50°C - 65°C)
 - 185°F (85°C) during disinfection

Performance

- Thermal shutdown upon inlet supply failure
- +/- 2°F (+/- 1°C) delivery temperature stability
- Minimum flow rate at recommended supply conditions:
 - 1 GPM (4 LPM) at <72 psi maintained pressure
 - 1.6 GPM (6 LPM) at >72 psi maintained pressure.

Thermal Disinfection

- Factory Settings
 - Min. Temperature: 140°F (60°C)
 - Min. Time: 5 minutes
- Programmable Range
 - Min. Temperature: 140 - 185°F (60 - 85°C)
 - Min. Time: 0 - 50 minutes

Reduced water flow during disinfection can be selected.

Environment

- Ambient temperature: 34°F - 104°F (1°C - 40°C)
- Maximum relative humidity: 95% non-condensing

Pressures

- Maximum static pressure: 145 psi (10 bar)
- Maximum inlet supply pressure differential: 3:1 (equal inlet pressures recommended)

IP Rating

- Control panel: IP45
- Overall valve enclosure: IP24
- Electronics compartment: IP45
- PSU: IP45

Electrical

- Supply Voltage: 120V 50-60Hz
- Maximum load: 20W at 12V DC
- Control panel cable length: 10 ft. (3m) supplied
- Maximum distance 20 ft. (6m)

Times - Factory settings

- Flow time: 15 seconds
- Service flush cycle: 2 minutes
- Service flush waiting period: 12 hours

Programmable range

- Flow time: 5 seconds - 60 minutes
- Service flush cycle: 1 minute - 59 minutes
- Service flush waiting period: 1 hour - 983 hours

Operation

- Temperature selector: Full no-touch temperature control
- Flow control: No-touch on/off - timed flow

Approvals

- ASSE 1016, CSA, UL

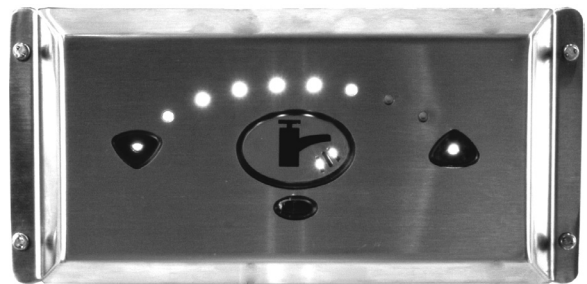

Optional Stainless Steel Control Panel Cover

Water Temperature Control - Single Point of Use

Digital

Sense™ Model DMV2

Concealed digital mixing valve with surface mount control panel for **individual shower** flow and +/-2°F (+/-1°C) temperature control.

Operational Specifications

- Programmable timed flow
- No touch on/off flow control
- No touch temperature adjustment
- Programmable minimum/maximum temperature access limits
- Programmable service flush
- Programmable thermal disinfection mode
- Data logging capabilities

For a submittal drawing, refer to D34256.

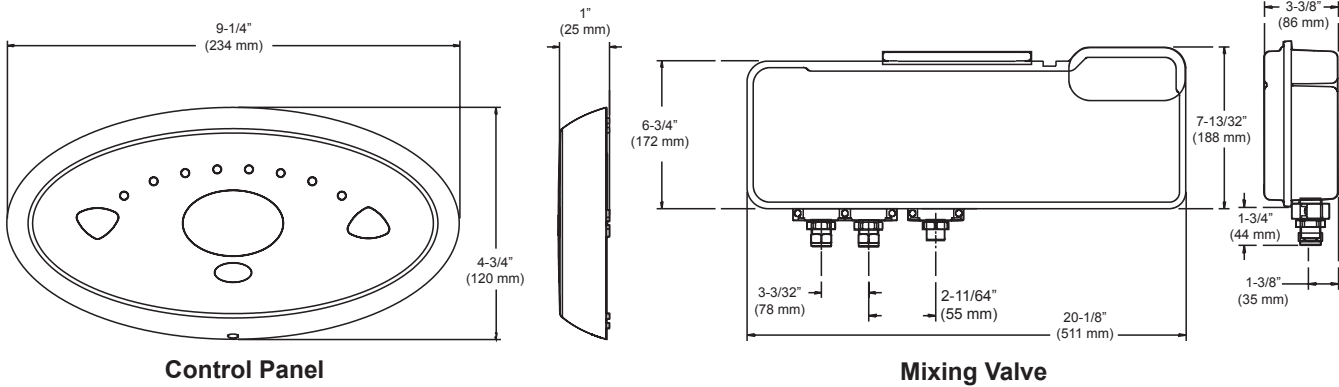

Sense™ Digital Mixing Valves												
Model	Pressure Drop (psi)										Min. Flow	Cv
	5	10	15	20	25	30	35	40	45	50		
DMV1	3	4	5	6	6	7	7	8	9	9	1	1.2
DMV2												
DMV3	6	8	10	11	12	14	15	16	17	18	1.6	2.5
DMV23												

Water Temperature Control - Single Point of Use

Digital

Sense™ Model DMV2-Individual Shower Technical Specifications

Connections

- Inlet and outlet connections: 1/2" NPT

Materials

- Control panel cover: Chrome ABS
- Mixing unit enclosure: PC/ABS
- Integral components: DZR brass stainless steel and engineering plastic

Temperatures

- Factory pre-set:
Min 86°F (30°C), Max 106°F (41°C),
Default 100°F (38°C)
- Programmable range:
Min 86°F - 117°F (30°C - 47°C),
Max 91°F - 122°F (33°C - 50°C),
Default 86°F - 122°F (30°C - 50°C)
Full cold can also be selected
- Minimum blend temperature differential from hot supply:
5°F (2°C)
- Optimum thermostatic control range:
86°F - 122°F (30°C - 50°C)
- Inlet Cold water range (recommended):
34°F - 68°F (1°C - 20°C)
- Inlet Hot water range (recommended):
122°F - 149°F (50°C - 65°C)
185°F (85°C) during disinfection

Performance

- Thermal shutdown upon inlet supply failure
- +/- 2°F (+/- 1°C) delivery temperature stability
- Minimum flow rate at recommended supply conditions:
1 GPM (4 LPM) at <72 psi maintained pressure
1.6 GPM (6 LPM) at >72 psi maintained pressure.

Thermal Disinfection

- Factory Settings
Min. Temperature: 140°F (60°C)
Min. Time: 5 minutes
- Programmable Range
Min. Temperature: 140 - 185°F (60 - 85°C)
Min. Time: 0 - 50 minutes
Reduced water flow during disinfection can be selected.

Environment

- Ambient temperature: 34°F - 104°F (1°C - 40°C)
- Maximum relative humidity: 95% non-condensing

Pressures

- Maximum static pressure: 145 psi (10 bar)
- Maximum inlet supply pressure differential: 3:1 (equal inlet pressures recommended)

IP Rating

- Control panel: IP45
- Overall valve enclosure: IP24
- Electronics compartment: IP45
- PSU: IP45

Electrical

- Supply Voltage: 120V 50-60Hz
- Maximum load: 20W at 12V DC
- Control panel cable length: 10 ft. (3m) supplied
- Maximum distance 20 ft. (6m)

Times - Factory settings

- Flow time: 15 seconds
- Service flush cycle: 2 minutes
- Service flush waiting period: 12 hours

Programmable range

- Flow time: 5 seconds - 60 minutes
- Service flush cycle: 1 minute - 59 minutes
- Service flush waiting period: 1 hour - 983 hours

Operation

- Temperature selector: Full no-touch temperature control
- Flow control: No-touch on/off - timed flow

Approvals

- ASSE 1016, CSA, UL

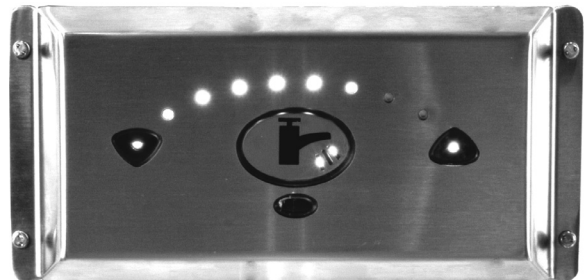

Optional Stainless Steel Control Panel Cover

Water Temperature Control - Single Point of Use

Digital

Sense™ Model DMV3-Individual Bath

Concealed digital mixing valve with surface mount control panel for individual bath fill and +/-2°F (+/-1°C) temperature control.

Operational Specifications

- Programmable timed flow
- No touch on/off flow control
- No touch temperature adjustment
- Programmable minimum/maximum temperature access limits
- Programmable service flush
- Programmable thermal disinfection mode
- Data logging capabilities

For a submittal drawing, refer to D34257.

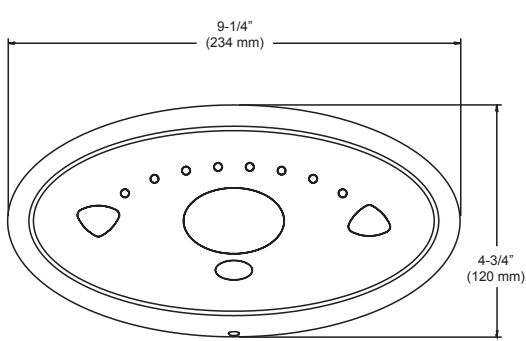

Control Panel

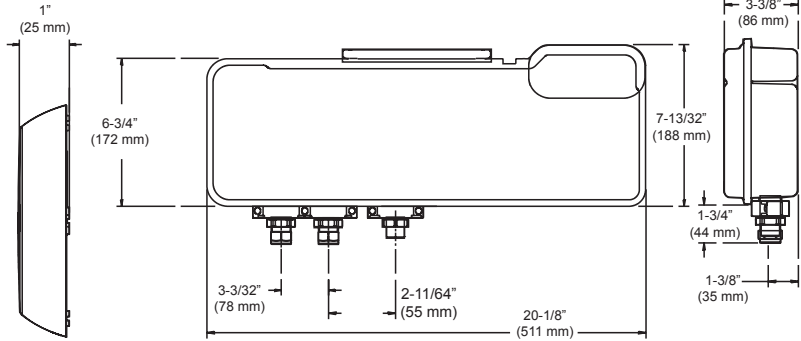

Mixing Valve

Sense™ Digital Mixing Valves												
Model	Pressure Drop (psi)										Min. Flow	Cv
	5	10	15	20	25	30	35	40	45	50		
DMV1	3	4	5	6	6	7	7	8	9	9	1	1.2
DMV2												
DMV3	6	8	10	11	12	14	15	16	17	18	1.6	2.5
DMV23												

Water Temperature Control - Single Point of Use

Digital

Sense™ Model DMV3-Individual Bath Technical Specifications

Connections

- Inlet and outlet connections: 3/4" NPT

Materials

- Control panel cover: Chrome ABS
- Mixing unit enclosure: PC/ABS
- Integral components: DZR brass stainless steel and engineering plastic

Temperatures

- Factory pre-set:
Min 86°F (30°C), Max 106°F (41°C),
Default 104°F (40°C)
- Programmable range:
Min 86°F - 117°F (30°C - 47°C),
Max 91°F - 122°F (33°C - 50°C),
Default 86°F - 122°F (30°C - 50°C)
Full cold can also be selected
- Minimum blend temperature differential from hot supply:
5°F (2°C)
- Optimum thermostatic control range:
86°F - 122°F (30°C - 50°C)
- Inlet Cold water range (recommended):
34°F - 68°F (1°C - 20°C)
- Inlet Hot water range (recommended):
122°F - 149°F (50°C - 65°C)
185°F (85°C) during disinfection

Performance

- Thermal shutdown upon inlet supply failure
- +/- 2°F (+/- 1°C) delivery temperature stability
- Minimum flow rate at recommended supply conditions:
1.6 GPM (6 LPM) at <72 psi maintained pressure
2 GPM (8 LPM) at >72 psi maintained pressure.

Thermal Disinfection

- Factory Settings
Min. Temperature: 140°F (60°C)
Min. Time: 5 minutes
- Programmable Range
Min. Temperature: 140 - 185°F (60 - 85°C)
Min. Time: 0 - 50 minutes
Reduced water flow during disinfection can be selected.

Environment

- Ambient temperature: 34°F - 104°F (1°C - 40°C)
- Maximum relative humidity: 95% non-condensing

Pressures

- Maximum static pressure: 145 psi (10 bar)
- Maximum inlet supply pressure differential: 3:1 (equal inlet pressures recommended)

IP Rating

- Control panel: IP45
- Overall valve enclosure: IP24
- Electronics compartment: IP45
- PSU: IP45

Electrical

- Supply Voltage: 120V 50-60Hz
- Maximum load: 20W at 12V DC
- Control panel cable length: 10 ft. (3m) supplied
- Maximum distance 20 ft. (6m)

Times - Factory settings

- Flow time: 300 seconds
- Service flush cycle: 2 minutes
- Service flush waiting period: 12 hours

Programmable range

- Flow time: 5 seconds - 60 minutes
- Service flush cycle: 1 minute - 59 minutes
- Service flush waiting period: 1 hour - 983 hours

Operation

- Temperature selector: Full no-touch temperature control
- Flow control: No-touch on/off - timed flow

Approvals

- ASSE 1016, CSA, UL

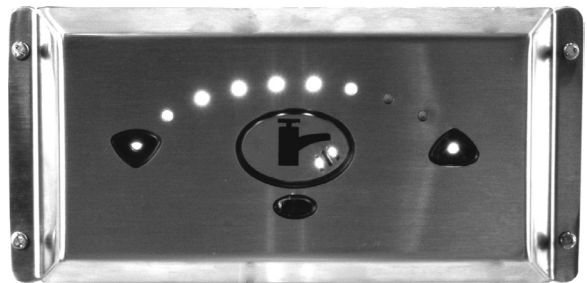

Optional Stainless Steel Control Panel Cover

Water Temperature Control - Single Point of Use

Digital

Sense™ Model DMV23-Bath and Shower

Concealed digital mixing valve with surface mount control panel for combination **bath and shower** flow and $\pm 2^{\circ}\text{F}$ ($\pm 1^{\circ}\text{C}$) temperature control.

Operational Specifications

- Programmable timed flow
- No touch on/off flow control
- No touch temperature adjustment
- Programmable minimum/maximum temperature access limits
- Programmable service flush
- Programmable thermal disinfection mode
- Data logging capabilities

For a submittal drawing, refer to D34258.

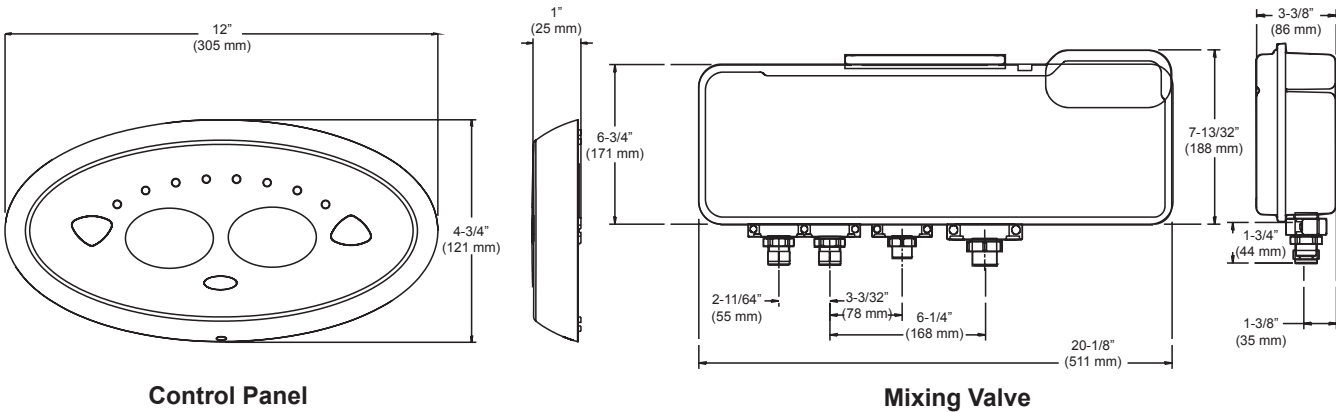

Sense™ Digital Mixing Valves												
Model	Pressure Drop (psi)										Min. Flow	C _v
	5	10	15	20	25	30	35	40	45	50		
DMV1	3	4	5	6	6	7	7	8	9	9	1	1.2
DMV2												
DMV3	6	8	10	11	12	14	15	16	17	18	1.6	2.5
DMV23												

Water Temperature Control - Single Point of Use

Digital

Sense™ Model DMV23-Bath and Shower Technical Specifications

Connections

- Inlet connections: 3/4" NPT
- Outlet connection: Bath 3/4" NPT, Shower 1/2" NPT

Materials

- Control panel cover: Chrome ABS
- Mixing unit enclosure: PC/ABS
- Integral components: DZR brass stainless steel and engineering plastic

Temperatures

- Factory pre-set:
 - Shower: Min 86°F (30°C), Max 106°F (41°C), Default 100°F (38°C)
 - Bath: Min 86°F (30°C), Max 111°F (44°C), Default 104°F (40°C)
- Programmable range:
 - Min 86°F - 117°F (30°C - 47°C),
 - Max 91°F - 122°F (33°C - 50°C),
 - Default 86°F - 122°F (30°C - 50°C)
 - Full cold can also be selected
- Minimum blend temperature differential from hot supply: 5°F (2°C)
- Optimum thermostatic control range:
 - 86°F - 122°F (30°C - 50°C)
- Inlet Cold water range (recommended):
 - 34°F - 68°F (1°C - 20°C)
- Inlet Hot water range (recommended):
 - 122°F - 149°F (50°C - 65°C)
 - 185°F (85°C) during disinfection

Performance

- Thermal shutdown upon inlet supply failure
- +/- 2°F (+/- 1°C) delivery temperature stability
- Minimum flow rate at recommended supply conditions:
 - 1.6 GPM (6 LPM) at <72 psi maintained pressure
 - 2 GPM (8 LPM) at >72 psi maintained pressure.

Thermal Disinfection

- Factory Settings
 - Min. Temperature: 140°F (60°C)
 - Min. Time: 5 minutes
- Programmable Range
 - Min. Temperature: 140 - 185°F (60 - 85°C)
 - Min. Time: 0 - 50 minutes

Reduced water flow during disinfection can be selected.

Environment

- Ambient temperature: 34°F - 104°F (1°C - 40°C)
- Maximum relative humidity: 95% non-condensing

Pressures

- Maximum static pressure: 145 psi (10 bar)
- Maximum inlet supply pressure differential: 3:1 (equal inlet pressures recommended)

IP Rating

- Control panel: IP45
- Overall valve enclosure: IP24
- Electronics compartment: IP45
- PSU: IP45

Electrical

- Supply Voltage: 120V 50-60Hz
- Maximum load: 20W at 12V DC
- Control panel cable length: 10 ft. (3m) supplied
- Maximum distance 20 ft. (6m)

Times - Factory settings

- Flow time shower: 30 seconds
- Flow time bath: 300 seconds
- Service flush cycle: 2 minutes
- Service flush waiting period: 12 hours

Programmable range

- Flow time shower : 5 seconds - 60 minutes
- Flow time bath : 5 seconds - 60 minutes
- Duty flush cycle: 1 minute - 59 minutes
- Duty flush waiting period: 1 hour - 983 hours

Operation

- Temperature selector: Full no-touch temperature control
- Flow control: No-touch on/off - timed flow
- Independent bath and shower control

Approvals

- ASSE 1016, CSA, UL

Installation

General

Installation must be performed in accordance with these instructions, and must be conducted by designated, qualified and competent installers.

The installation must comply with all local, state and national plumbing codes.

Caution!

The Digital Mixing Valve (DMV) and Power Supply Unit (PSU) must be installed in a dry area and where it will not freeze. The DMV must only be used with the, UL listed PSU specified in this manual.

Flat face union connections must be used on the inlet and outlet connections of the DMV ease of maintenance.

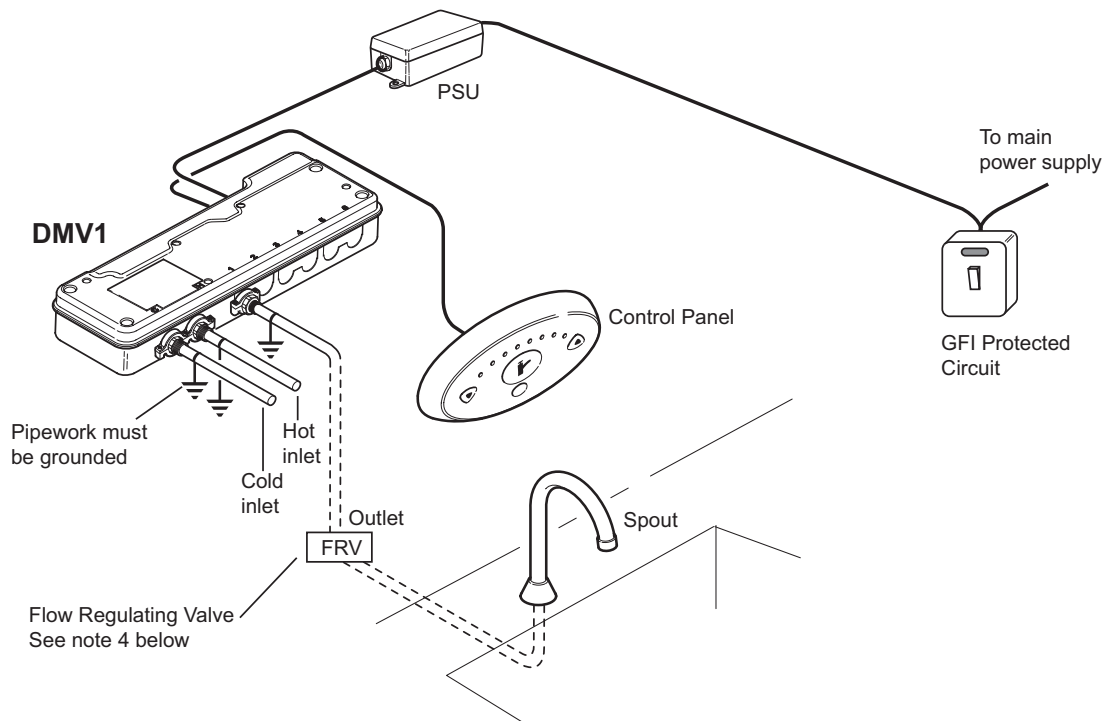

1. Inlet and outlet shut-off valves must be installed close to the DMV for ease of maintenance.
2. Inlet strainers will reduce the need to remove debris at each mixing valve point. The recommended maximum mesh aperture dimensions for such strainers is 0.02 inch (0.5 mm).
3. Inlet pressure tapplings which enable the measurement of the inlet pressures to the mixing valve under operating conditions are particularly recommended for healthcare applications.
4. **For systems with static water pressure greater than 30 psi a flow regulating valve (FRV) installed in the mixing valve outlet pipework is strongly recommended to set/adjust flow volume to the fixture.**
5. Pipework should be well supported to avoid any strain on the connections.
6. Pipework dead-legs should be kept to a minimum.

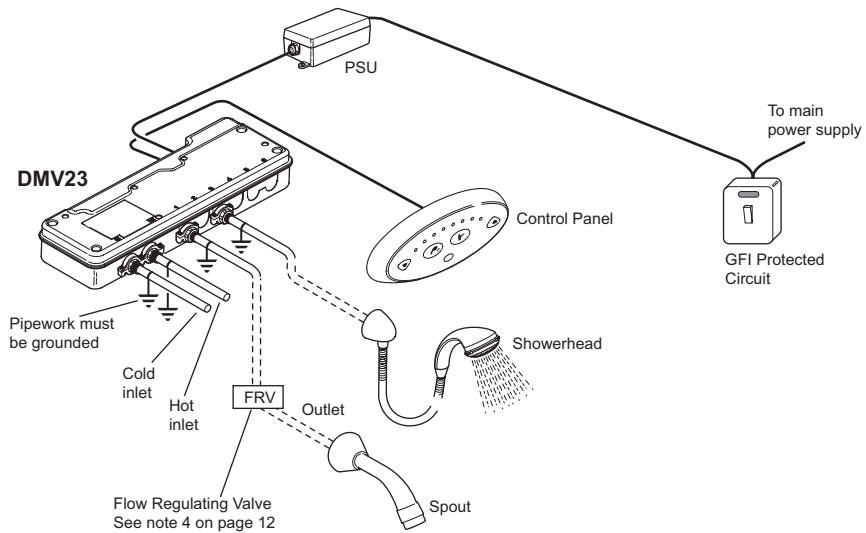
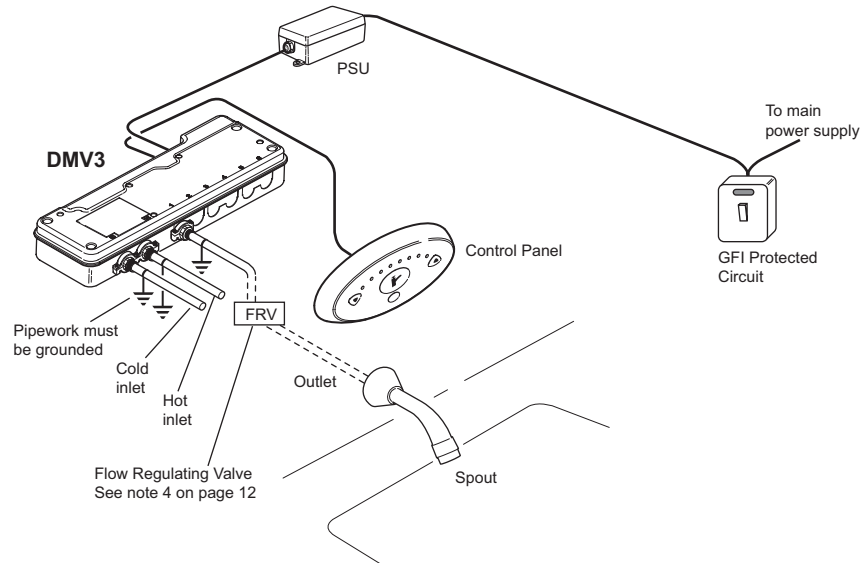
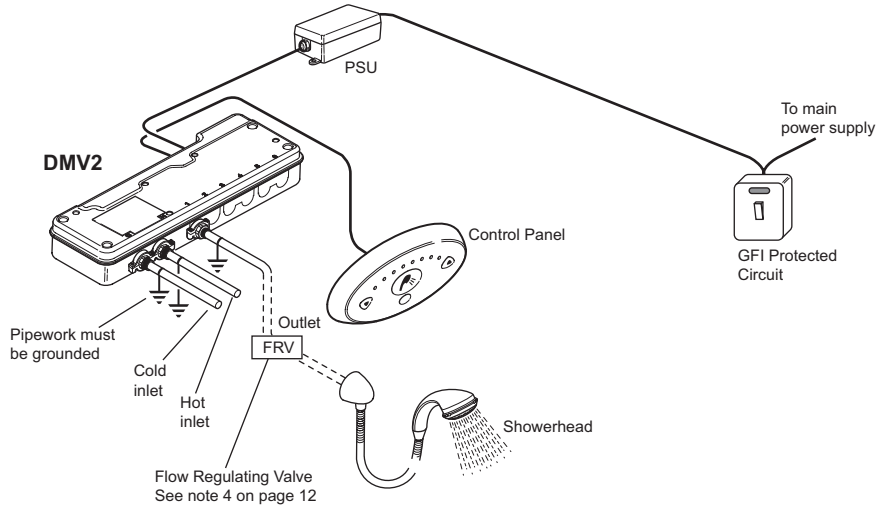

7. Supply pipework layout should be arranged to minimize the effect of other outlet usage upon the dynamic pressures at the mixing valve inlets.
8. Inlet and outlet threaded joint connections should be wrapped with PTFE tape or liquid sealant. Do not use oil-based, non-setting joint compounds.
9. To eliminate pipe debris it is essential that supply pipes are thoroughly flushed through before connection to the fixture and the DMV.
10. The DMV may only be installed in the following orientations.

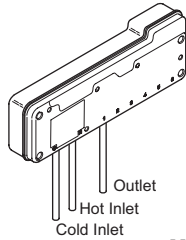

Mounting on a vertical surface

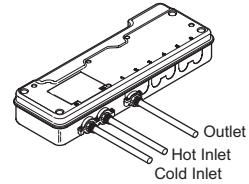
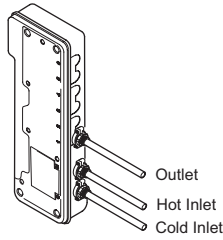

Mounting on a horizontal surface

Power Supply Unit (PSU)

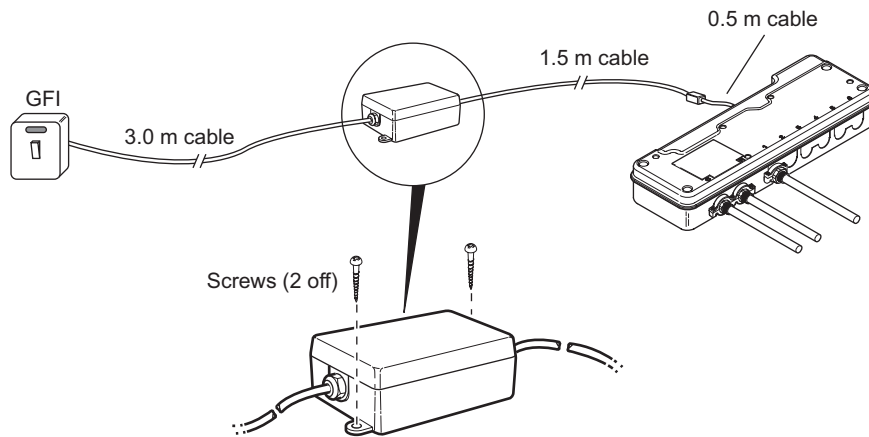

Warning!

Disconnect the primary power supply before beginning the installation or servicing. The PSU must be connected to a 3 amp circuit breaker.

Suppression Ferrites

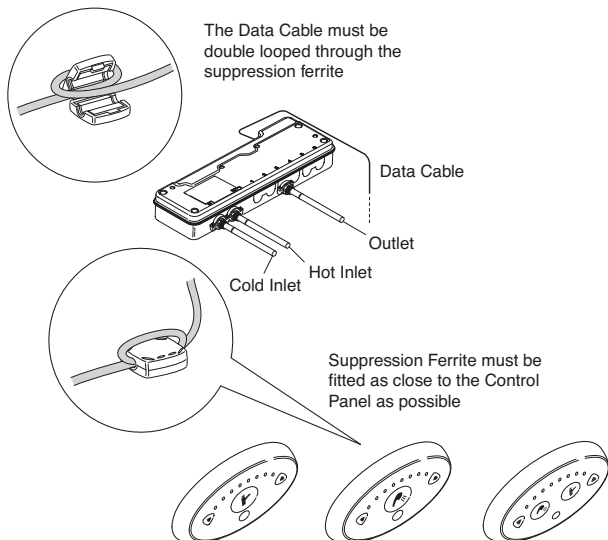

The data cable connection between the DMV and the control panel must have a black suppression ferrite fitted (supplied). This has not been factory fitted to allow for installations which require the cable to be passed through a small gap.

Make sure that after routing the cable the suppression ferrite is fitted as close to the control panel as possible.

Control Panel

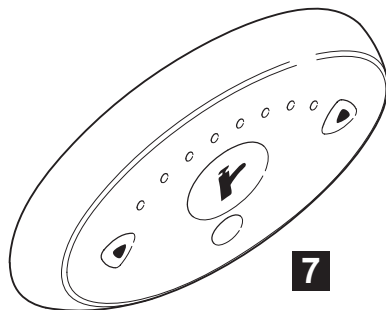
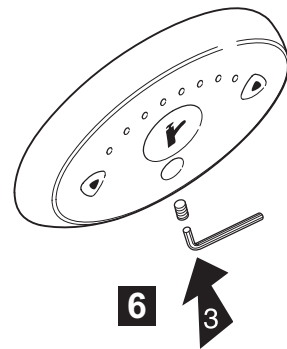
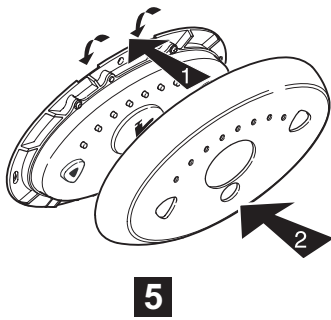
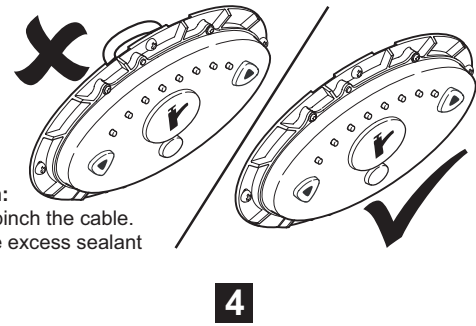
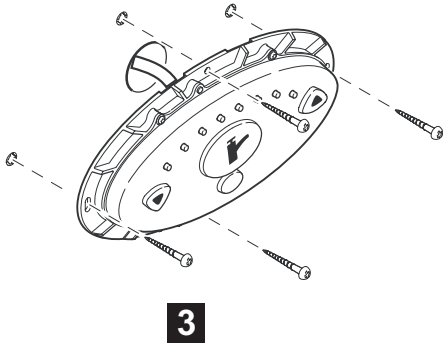
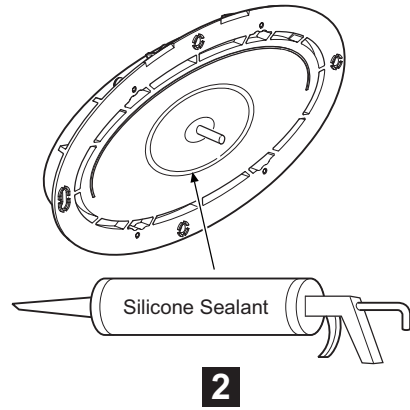
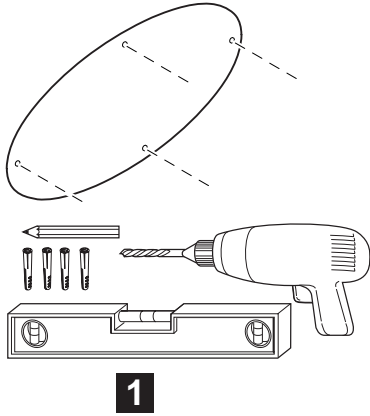

Digital Mixing Valve (DMV)

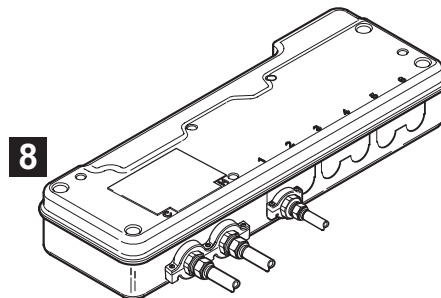
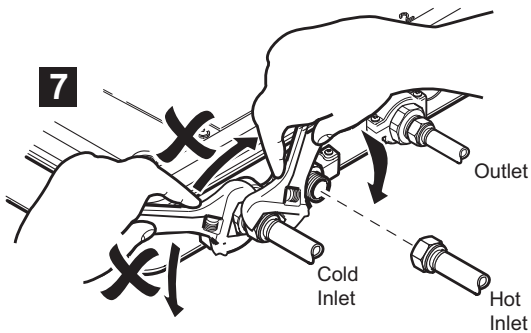
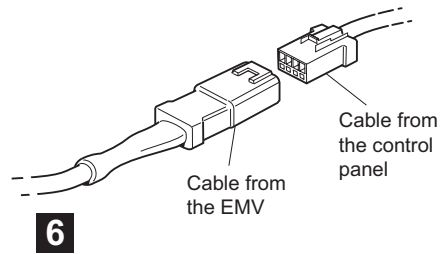
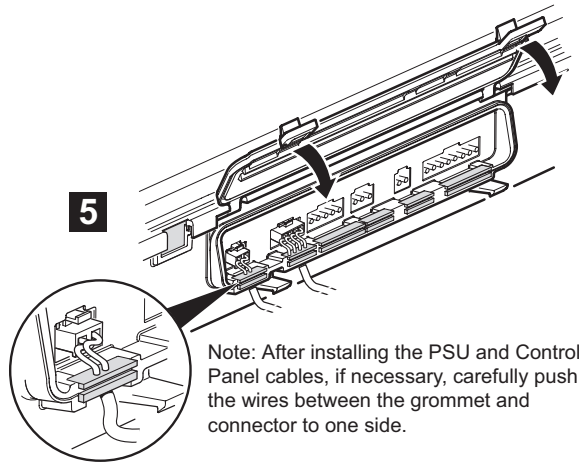
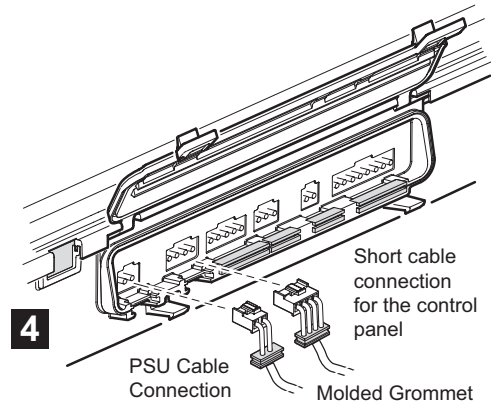
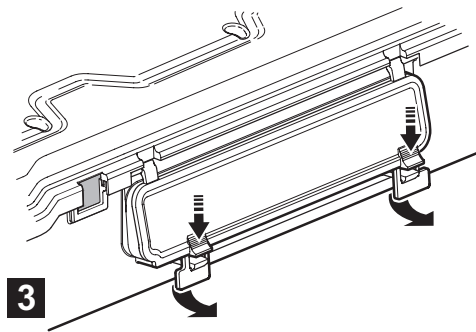
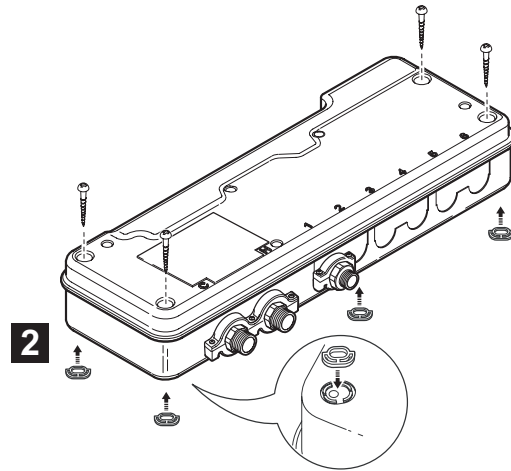
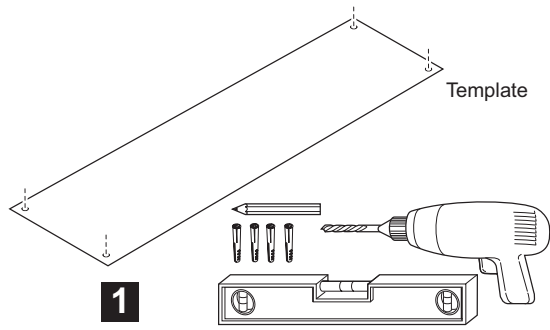

Commissioning

Technical specifications which include factory presets, programmable changes and other important detail are included on page 5 (DMV1), page 7 (DMV2), page 9 (DMV3) and page 11 (DMV23) of this IOM.

Commissioning must be carried out in accordance with these instructions, and must be conducted by designated, qualified and competent technicians.

Note: For Healthcare Installations, commissioning results, programming requirements and maintenance recording is strongly recommended.

After installation proceed as follows:

1. Open the inlet water supplies and check that there are no leaks.
2. Turn on power to the DMV.
3. Position your hand over the flow sensor (indicated by either a faucet or a shower icon or both) on the control panel to start the DMV, and to flush out any air.
4. Check to ensure that the supply temperatures and pressures are within the recommended range*.
5. Check inlet pipework temperatures for the correct function of check valves, i.e. the hot water does not cross flow into the cold water supply.
6. Check that the temperature(s) and flow rates obtainable are acceptable.
7. Initiate performance check.

Performance Check

Healthcare

Turn off the cold water supply to the mixing valve and monitor the mixed water temperature. Record the maximum temperature achieved and the final stabilized temperature on restoration of the cold water supply.

Note: The final stabilized mixed water temperature should not exceed the values shown below. Any higher temperatures should only occur briefly.

Lavatory	106°F (41 °C)
Shower	106°F (41 °C)
Bath	104°F (40 °C)

Commercial

Locate another outlet on the common cold water supply close to the mixing valve (operating this outlet should cause a drop in supply pressure), and note the subsequent effect on the blended temperature (should be no more than 4°F (2 °C) change).

Maximum Temperature Setting

The maximum outlet temperature obtainable by the user is limited to prevent accidental selection of a temperature that is too hot.

The DMV is fully performance tested and the maximum temperature is factory preset.

The factory preset maximum temperature should not require any adjustment.

Should the user require a different maximum temperature, the unit can be programmed with a computer and an infrared device. Refer to separate **Programmer IOM AHWG-700**. Download the software at armstronginternational.com/files/products/wheaters/sense_laptop_software.zip

Note: The outlet temperature must be re-checked after a new temperature has been programmed.

*Technical specifications which include factory presets, programmable changes and other important detail are included on page 5 (DMV1), page 7 (DMV2), page 9 (DMV3) and page 11 (DMV23) of this IOM.

Operation

Position your hand over the flow sensor (indicated by either a faucet or a shower icon or both) on the control panel to activate the DMV. After the static dead leg is evacuated water will be delivered at the pre-programmed default temperature.

Flow

The sensors are designed to operate at a distance of up to 1.2 inches (30 mm).

There is no need for the user to touch the control panel.

The water should flow until either it is switched off manually (by positioning your hand over the flow sensor) or the programmed flow time duration has elapsed.

Temperature Adjustment

Position your hand over the Down arrow to reduce outlet temperature.

Note: Full Cold water flows only when the blue light is illuminated on the control panel and the Full Cold option is selected during programming/set-up.

Position your hand over the Up arrow to increase outlet temperature.

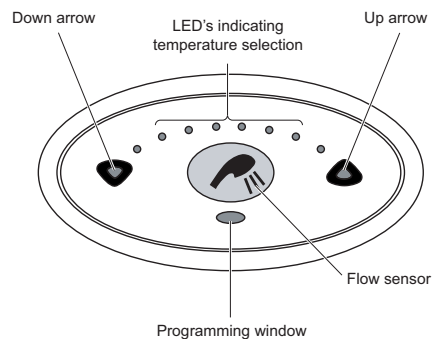

Service Flush

The DMV incorporates an option for a periodic service flush which can be selected with the aid of the Programmer. If service flush is selected and the DMV is not used for a period of time (pre-set waiting period) the standing water within the DMV will be flushed out.

Service flush temperature, waiting period and flush period are preset at the factory. With the aid of the Programmer, these settings can be reset.

Cleaning

The DMV Control Panel may be temporarily disabled for cleaning purposes.

Place the magnetic key (supplied) over the programming window. This will disable the sensors for 30 minutes or until the magnetic key is reapplied.

External surfaces may be wiped clean with a soft cloth, and if necessary, a mild cleaning detergent or soap solution can be used.

Caution:

Plated or plastic fittings should only be cleaned using a mild detergent or soap solution and wiped dry with a soft cloth.

Fault Diagnosis

Maintenance must be conducted by designated, qualified and competent technicians.

Warning:

Disconnect the power supply and water supply when any maintenance work is carried out on the DMV.

The DMV may contain hot water, so care must be taken when draining the DMV of any residual water.

Caution:

The inlet/outlet connections, on the DMV, must be held tightly so that they do not move when the connections are being loosened or tightened.



Symptom	
1. Control panel not illuminated	Check that you have the correct panel or DMV for your application.
	Control panel has been disabled; enable the control panel with the magnetic key, refer to cleaning .
	No electrical supply; check/rectify.
	The power supply unit has been disabled; check the fuse and connections.
	Electrical connections to/from the DMV have been disturbed; check/rectify.
	Memory requires resettling, switch the power supply to the electronic mixing valve, OFF and then ON.
2. Only cold water from outlet	No hot water reaching mixing valve, check/rectify.
	The hot water inlet may be blocked. Check strainer for any blockage.
	Installation conditions are outside the operating parameters, refer to Pages 5 (DMC1), 7 (DMV2), 9 (DMV3), and 11 (DMV23).
	Reversed inlet supplied. Check/rectify.
3. Continuous flow	System switches itself on and off. Isolate power supply/water supply and contact Armstrong Hot Water Group.
	System switches itself on and off. Isolate power supply/water supply and contact Armstrong Hot Water Group.
4. Hot water entering the cold supply or vice versa	Remove and clean the shut-off valve cartridges. Repeat as necessary.
5. Fluctuating or reduced flow rate. Normal function of mixing valve when operating conditions are unsatisfactory.	The inlet/outlet fittings may be restricted. Check the inlet/outlet strainers, refer to planned maintenance .
	The water outlet pressure is low. Verify the flow rate is above the stated minimum, refer to the specifications .
	Fluctuating flow. Make sure that dynamic inlet pressures are within specification, refer to the specifications .
	Fluctuating water temperature. Make sure that inlet temperature differentials are sufficient. Refer to the specifications .
6. Blend temperature drift or temperature cycling	Refer to symptoms 4 and 5.
	Hot water supply temperature fluctuation. Check/rectify.
7. Maximum blend temperature setting too hot or too cool.	Incorrect maximum temperature setting. Refer to commissioning .
8. Water leaking from the DMV.	Warning! Disconnect the main power supply. Check that the connections are secure.
	Seal(s) worn or damaged on the inlet/outlet connections. Obtain service pack and renew all seals.
	Internal leakage. Unit required overhaul.
9. LED's are flashing on the control panel and the DMV will not activate.	An error has been diagnosed, refer to self-diagnostic errors (following table).

Self-Diagnostic Errors

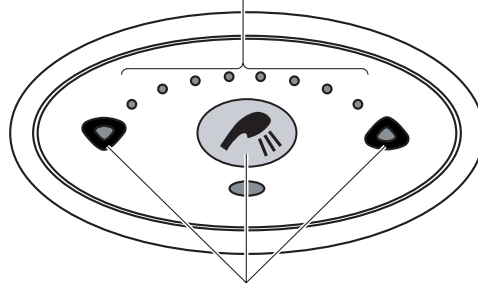
Error code is displayed by a combination of lit LED's

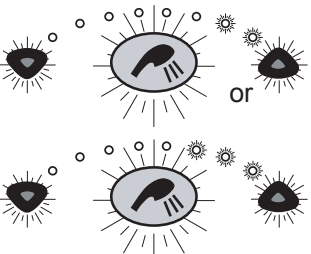
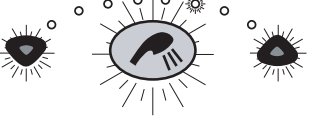

All three LED's flash at the same time

Symptom	Cause/Repair
	<p>The control panel and the DMV are not compatible.</p> <p>a. DMV W or B requires CP W. Check/rectify. If the system cannot be rectified isolate power/water supply and contact Armstrong Hot Water Inc. immediately.</p>
	<p>Outlet temperature is too high or Thermostat fault.</p> <p>a. The inlet/outlet fittings may be blocked. Check the inlet/outlet.</p> <p>b. Cold water supply failure. Reinststate supply.</p> <p>c. Safety circuit may require resetting. Enable the control panel with the magnetic key to reset.</p> <p>If the system cannot be rectified isolate power/water supply and contact Armstrong Hot Water Inc. immediately.</p>
	<p>Thermostat Fault</p> <p>a. Contact Armstrong Hot Water Inc. immediately.</p>
	<p>The stepper motor is stuck, the motor belt is broken or the mixer assembly is jammed.</p> <p>a. Contact Armstrong Hot Water Inc. immediately.</p>
	<p>The mixer assembly is jammed or very stiff.</p> <p>a. Contact Armstrong Hot Water Inc. immediately.</p>
Any other combinations.	<p>An error has occurred on the Control PCB.</p> <p>a. Memory may require resetting. Switch the power supply to the PSU, OFF and then ON.</p> <p>If the system cannot be rectified isolate power/water supply and contact Armstrong Hot Water Inc. immediately.</p>

Scheduled Maintenance

Malfunction of the DMV is almost always progressive in nature and will be detected by the use of proper temperature checking and maintenance routines.

We recommend a preventative maintenance procedure based on site conditions and the risk to the user. All results must be recorded.

Healthcare

Healthcare applications such as hospitals, rehabilitation centers, nursing/assisted living facilities and other installations where the user maybe at an enhanced level of risk are considered critical control applications.

Ultimately, the user or attendant must exercise diligence to make sure that the delivery of hygiene water is at a stable, safe temperature. This is particularly important in such procedures as supervised bathing where patients are unable to respond immediately to unsafe temperatures.

Regardless of supply and usage conditions or the evidence of in-service tests, the critical components listed in the table below, should be replaced at intervals of no longer than 5 years.

Note: During the replacement of critical components, it may be necessary to replace other non-critical components.

Critical Components	
Pack Number	Description
D35437	DMV Solenoid Manifold DMV 1, 2, 3 and 23
D35430	Thermistor Pack

Frequency of In-Service Tests

Healthcare Installations

Follow the procedure detailed in the flow diagram “Scheduled Test Procedure” on following page 22.

This procedure must be followed 6 to 8 weeks post-commissioning and again at 12 to 15 weeks post-commissioning.

The recorded blend temperature (T_b) from these two tests will determine the maximum frequency for future service intervals.

Result of 6-8 week test	Result of 12-15 week test	Next Service Interval
< 2°F (1°C)	< 2°F (1°C)	9 - 12 Weeks
> 2°F (1°C)	< 2°F (1°C)	9 - 12 Weeks
< 2°F (1°C)	> 2°F (1°C)	9 - 12 Weeks
> 2°F (1°C)	> 2°F (1°C)	6 - 9 Weeks

The first 2 or 3 in-service test results should be used as a guide, in conjunction with a suitable risk assessment, to determine the schedule of future in-service tests.

More regular temperature checks should be made where increased risks are perceived, i.e. patients are unable to immediately respond to an increase in water temperature, by either shutting the water off or removing themselves from contact with the water.

Maintenance personnel should also make sure that the staff is aware of the importance of reporting temperature variations and when detected, these should be recorded in the Log Book.

General Institutional and Commercial Installations

Check for correct blend setting every 6 months. Follow the procedure detailed in the flow diagram “In-service Test Procedure”, every 12 months.

Scheduled Test Procedure

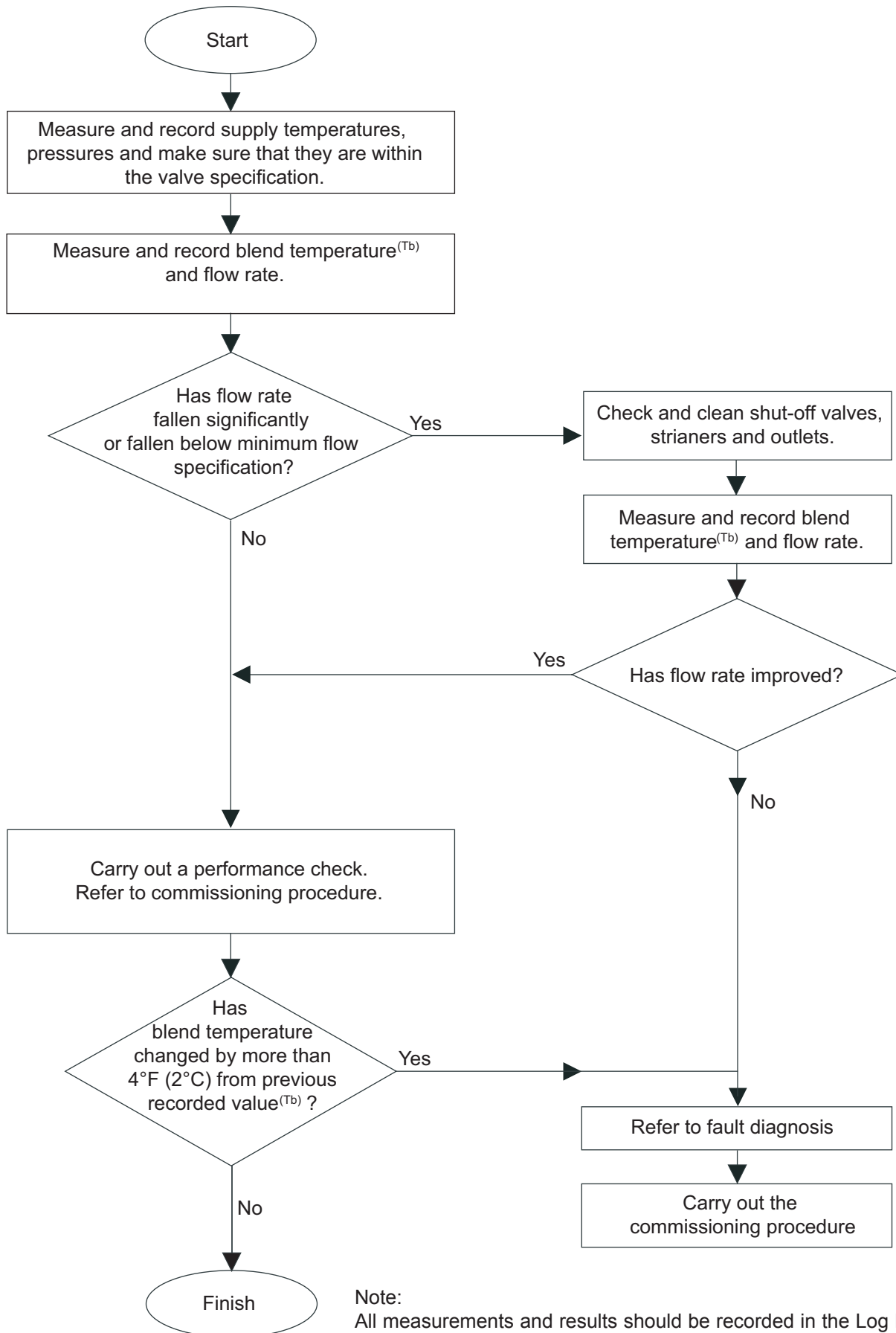

Note:
All measurements and results should be recorded in the Log Book.

Shut-off Valves and Filters

Isolate the supplies to the DMV and operate the control panel to release pressure and to assist the draining of residual water.

Warning:

The DMV may contain hot water, so care must be taken when draining the valve of any residual water.

Note: The DMV has check valves and filter packs (yellow cartridge assemblies).

The yellow check valve cartridge may be removed for cleaning. Inlet strainers can be flushed under a jet of water to remove any lodged particles.

Note: The check valves are not serviceable items, so any apparent wear or damage will require their renewal. Lightly wipe external seals with a **silicone-only based lubricant** to assist refitting.

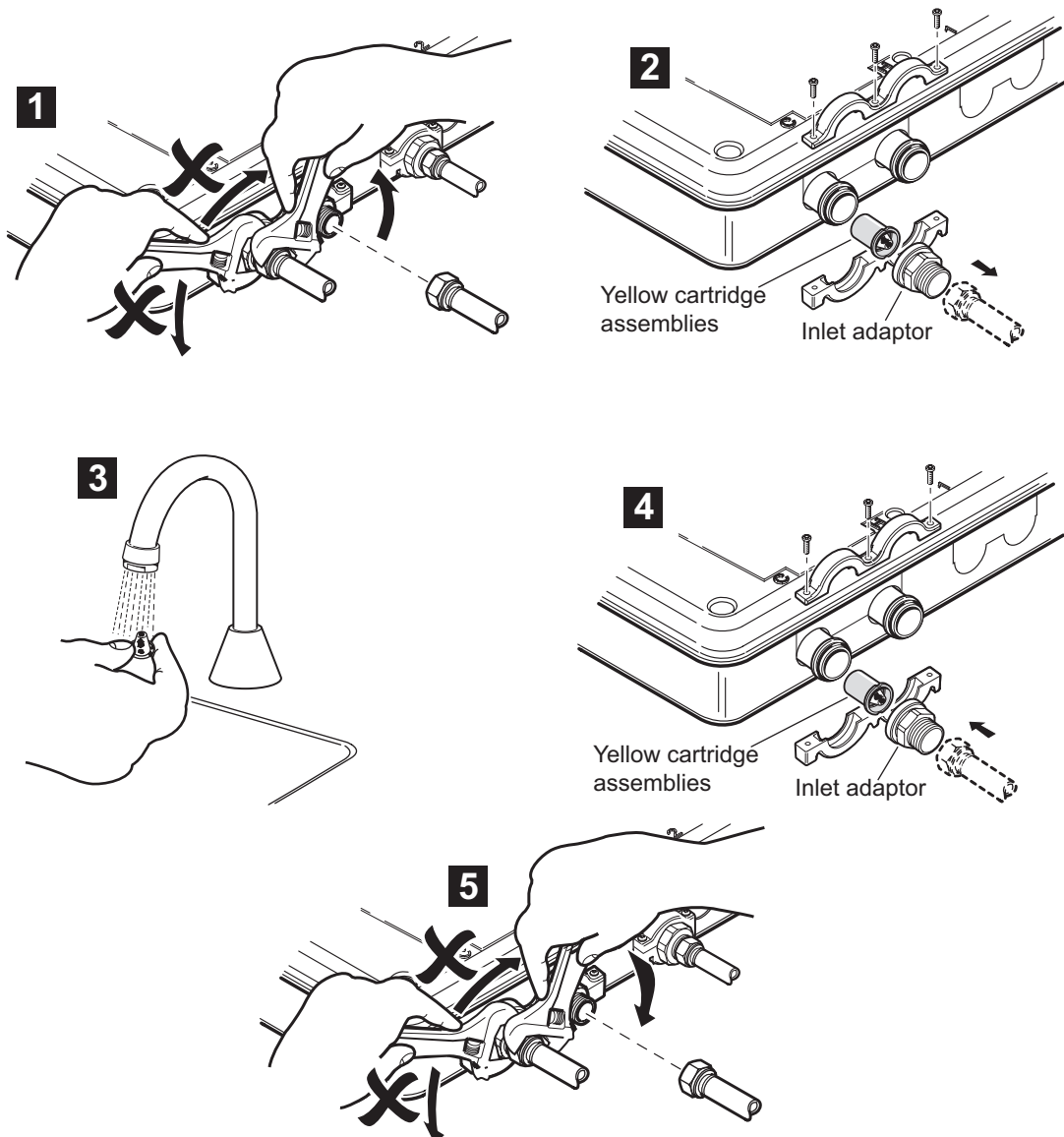

Restore the hot and cold water supplies. Check that there are no water leaks.

DMV1 Exploded View

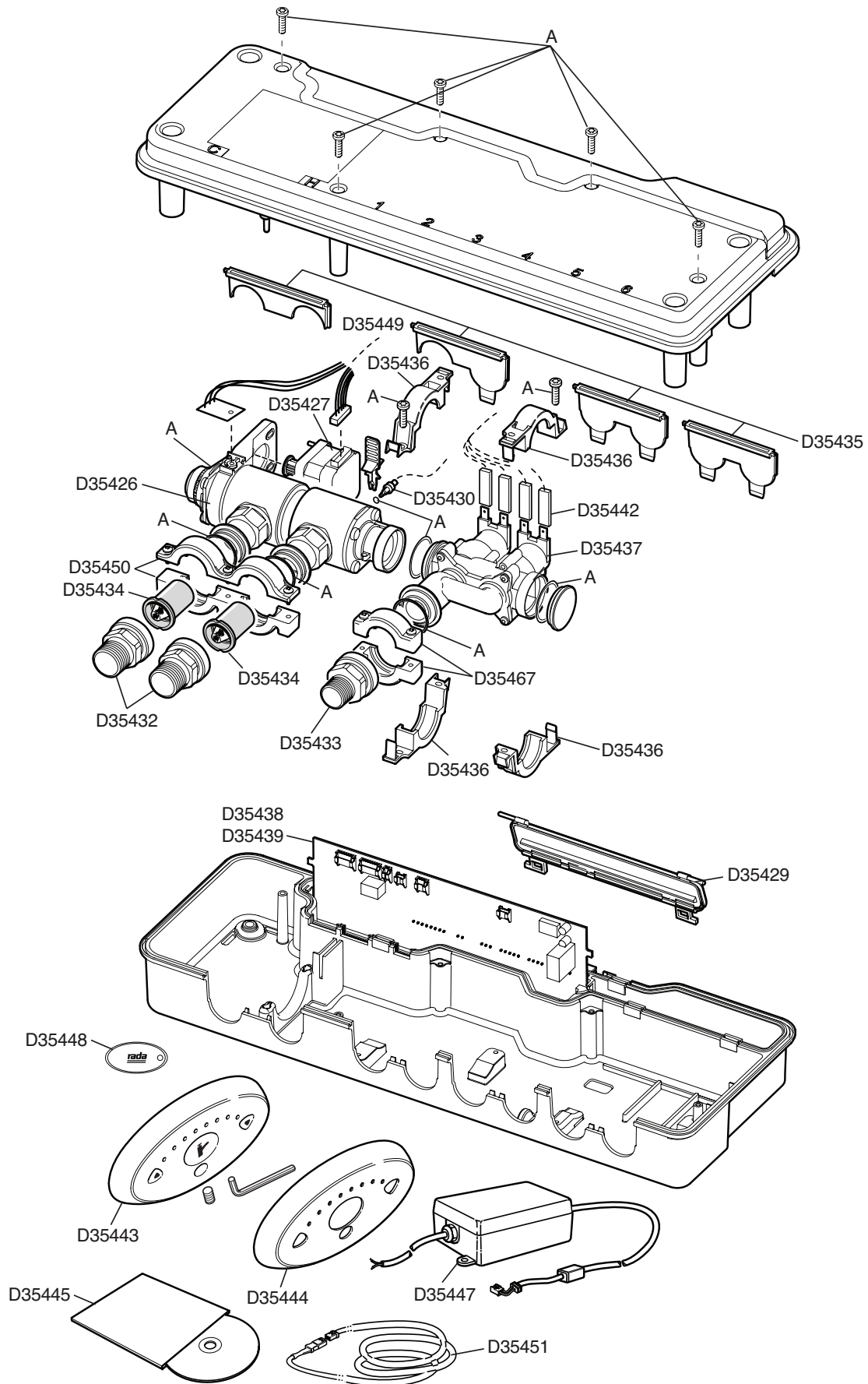

DMV1 Spare Parts

- D35426 C2 Valve Assembly - *Includes Stepper Motor, Stepper Loom, Checkvalve and Filter Pack, Inlet Saddle Clamps and Thermistor Clip*
- D35427 Stepper Motor Assembly - *Includes Timing Belt*
- D35428 Seal Screw Pack - *Components Identified 'A'*
- D35429 Cable Cover Pack
- D35430 Single Thermistor Pack
- D35432 Inlet Adapter 1/2 NPT - *x2 Adapters and Inlet Saddle Clamps*
- D35433 Outlet Adapter 1/2 NPT - *x1 Adapter and Outlet Saddle Clamps*
- D35434 Shut-off valve and filter pack
- D35435 Blanking Plate Pack
- D35436 Internal Saddle Clamp
- D35437 Solenoid Manifold (Open) - *Includes Manifold Cap and Internal Saddle Clamps*
- D35438 Control PCB RADA C2/C4 Basin - *Programmed with Basin Software*
- D35439 Control PCB RADA C2/C4 Bidet - *Programmed with Bidet Software*
- D35442 Wiring Loom RADA W/S/B/HP
- D35443 Rada Sense Washbasin/Bidet Control Panel
- D35444 Rada Sense Control Panel Cover 3 Sens (Chrome)
- D35445 Rada Sense Programmer CD
- D35447 12 V DC 45 W Power Supply Unit (PSU)
- D35448 Rada Sense Disable Key - *x4*
- D35449 Stepper Motor Loom
- D35467 Outlet Saddle Clamp
- D35450 Inlet Saddle Clamp

DMV-1 Accessories

- D35451 Extension Cord - 9 Feet/3 Meters

DMV2 Exploded View

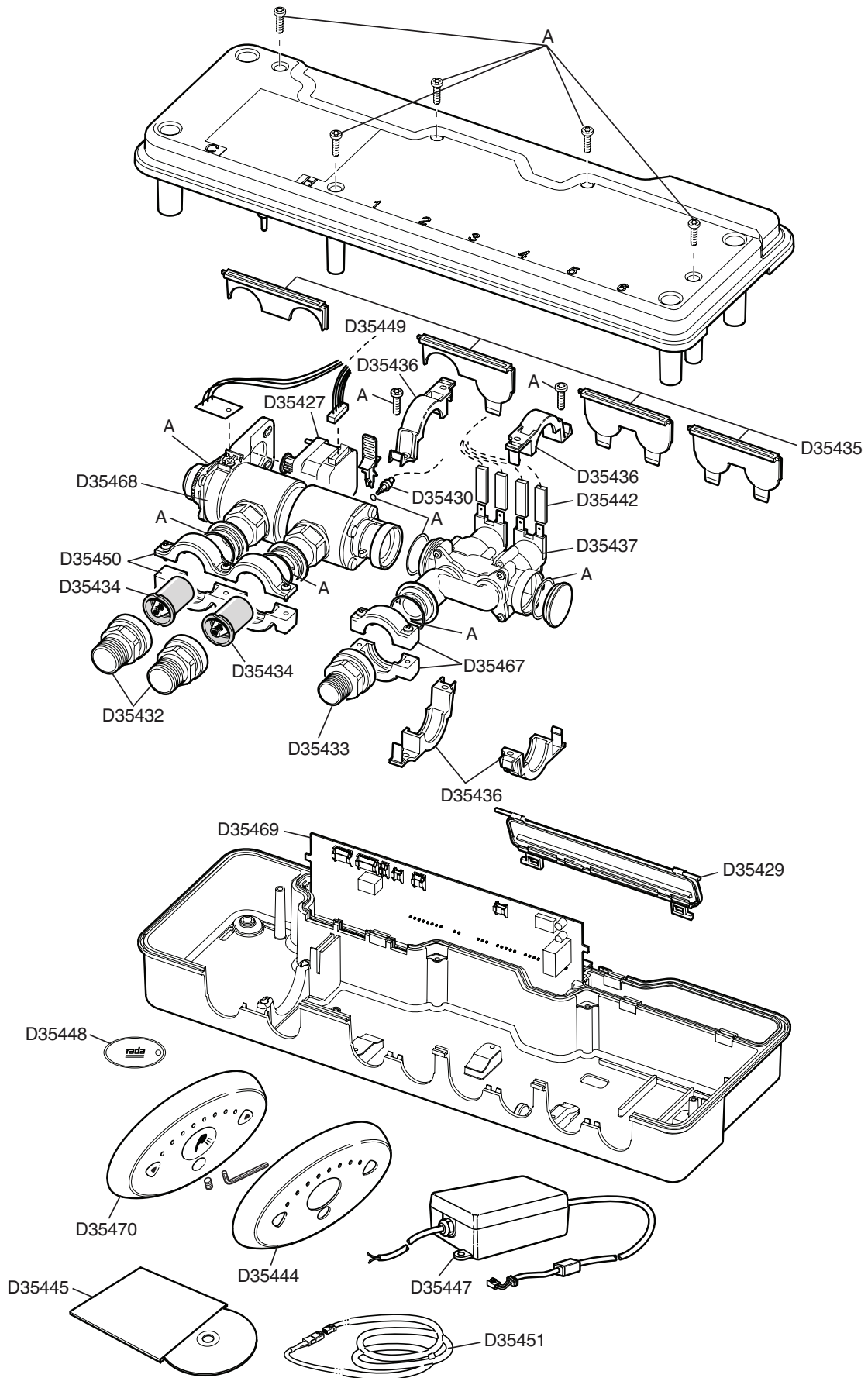

DMV2 Spare Parts

- D35468 C2 HP Valve Assembly - *Includes Stepper Motor, Stepper Loom, Checkvalve and Filter Pack, Inlet Saddle Clamps and Thermistor Clip*
- D35427 Stepper Motor Assembly - *Includes Timing Belt*
- D35428 Seal Screw Pack - *Components Identified 'A'*
- D35429 Cable Cover Pack
- D35430 Single Thermistor Pack
- D35432 Inlet Adapter 1/2 NPT - *x2 Adapters and Inlet Saddle Clamps*
- D35433 Outlet Adapter 1/2 NPT - *x1 Adapter and Outlet Saddle Clamps*
- D35434 Shut-off valve and filter pack
- D35435 Blanking Plate Pack
- D35436 Internal Saddle Clamp
- D35437 Solenoid Manifold (Open) - *Includes Manifold Cap and Internal Saddle Clamps*
- D35469 Control PCB RADA C2/C4 Shower - *Programmed with Shower Software*
- D35442 Wiring Loom RADA W/S/B/HP
- D35470 Rada Sense Shower Control Panel
- D35444 Rada Sense Control Panel Cover 3 Sens (Chrome)
- D35445 Rada Sense Programmer CD
- D35447 12 V DC 45 W Power Supply Unit (PSU)
- D35448 Rada Sense Disable Key - *x4*
- D35449 Stepper Motor Loom
- D35467 Outlet Saddle Clamp
- D35450 Inlet Saddle Clamp

DMV2 Accessories

- D35451 Extension Lead - 3 m

DMV3 Exploded View

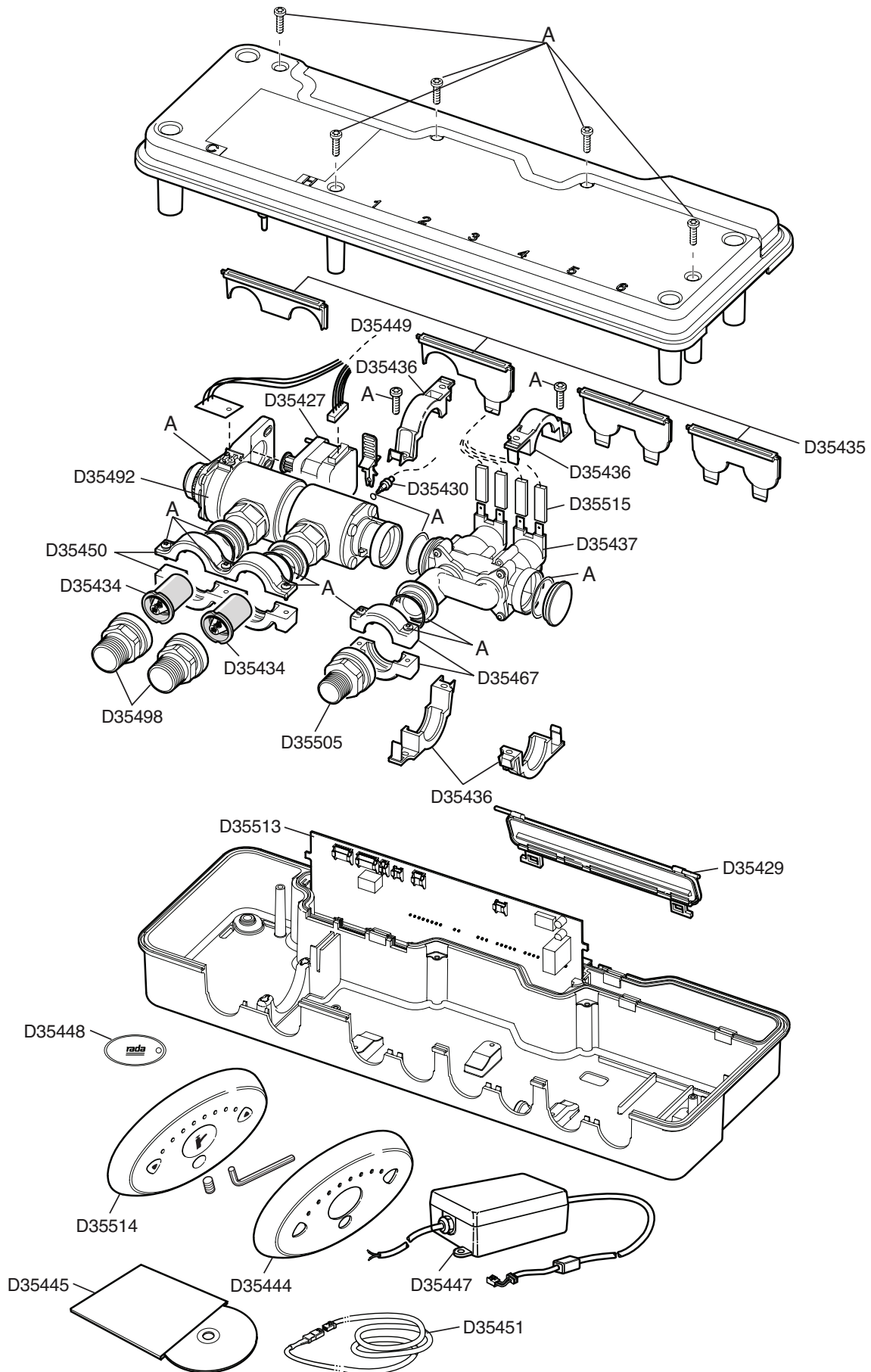

DMV3 Spare Parts

- D35435 C4 Valve Assembly - *Includes Stepper Motor, Stepper Loom, Checkvalve and Filter Pack, Inlet Saddle Clamps and Thermistor Clip*
- D35492 C4 Valve Assembly
- D35427 Stepper Motor Assembly - *Includes Timing Belt*
- D35428 Seal Screw Pack - *Components Identified 'A'*
- D35429 Cable Cover Pack
- D35430 Single Thermistor Pack
- D35498 Inlet Adapter 3/4 F-NPT - *x2 Adapters and Inlet Saddle Clamps*
- D35505 Outlet Adapter 3/4 F-NPT - *x1 Adapter and Outlet Saddle Clamps*
- D35434 Shut-off valve and filter pack
- D35435 Blanking Plate Pack
- D35436 Internal Saddle Clamp
- D35437 Solenoid Manifold (Open) - *Includes Manifold Cap and Internal Saddle Clamps*
- D35513 Control PCB RADA C2/C4 Bath - *Programmed with Bath Software*
- D35514 Rada Sense Bath Control Panel
- D35444 Rada Sense Control Panel Cover 3 Sens (Chrome)
- D35445 Rada Sense Programmer CD
- D35447 12 V DC 45 W Power Supply Unit (PSU)
- D35448 Rada Sense Disable Key - *x4*
- D35449 Stepper Motor Loom
- D35515 Wiring Loom RADA T
- D35467 Outlet Saddle Clamp
- D35450 Inlet Saddle Clamp

DMV3 Accessories

- D35451 Extension Lead - 3 m

DMV23 Exploded View

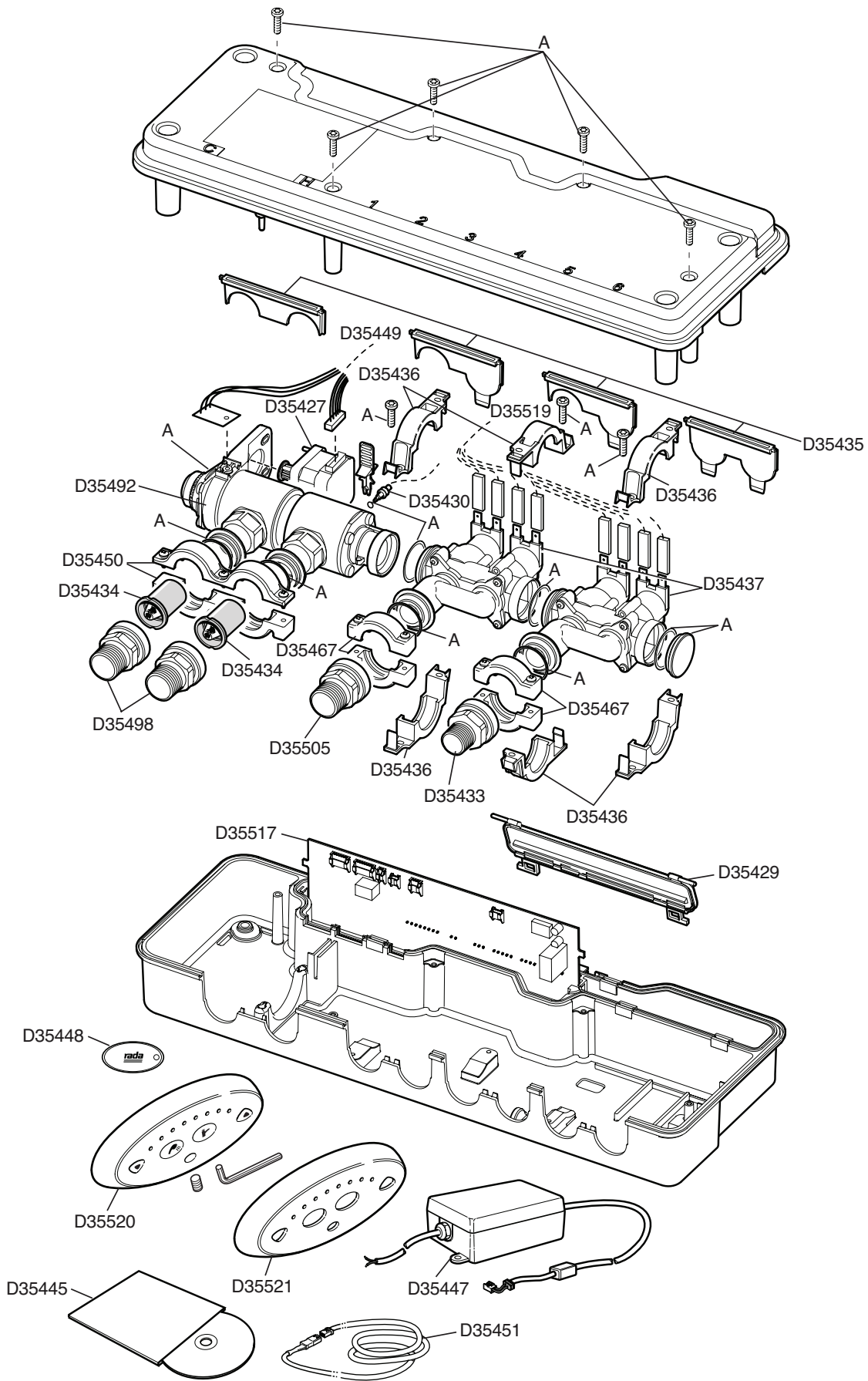

DMV23 Spare Parts

- D35492 C4 Valve Assembly- *Includes Stepper Motor, Stepper Loom, Checkvalve and Filter Pack, Inlet Saddle Clamps and Thermistor Clip*
- D35427 Stepper Motor Assembly - *Includes Timing Belt*
- D35428 Seal Screw Pack - *Components Identified 'A'*
- D35429 Cable Cover Pack
- D35430 1 Single Thermistor Pack
- D35498 Inlet Adapter 3/4 F-NPT - *x2 Adapters and Inlet Saddle Clamps*
- D35433 Outlet Adapter 1/2 NPT - *x1 Adapter and Outlet Saddle Clamps*
- D35505 Outlet Adapter 3/4 F-NPT - *x1 Adapter and Outlet Saddle Clamps*
- D35434 Shut-off valve and filter pack
- D35435 Blanking Plate Pack
- D35436 Internal Saddle Clamp
- D35437 Solenoid Manifold (Open) - *Includes Manifold Cap and Internal Saddle Clamps*
- D35517 Control PCB RADA C2/C4 BSM - *Programmed with Bath/Shower Software*
- D35519 Wiring Loom RADA BSM
- D35520 Rada Sense Bath/Shower Control Panel
- D35521 Rada Sense Control Panel Cover 4 Sens (Chrome)
- D35445 Rada Sense Programmer CD
- D35447 12 V DC 45 W Power Supply Unit (PSU)
- D35448 Rada Sense Disable Key - *x4*
- D35449 Stepper Motor Loom
- D35467 Outlet Saddle Clamp
- D35450 Inlet Saddle Clamp

DMV23 Accessories

- D35451 Extension Lead - 3 m

Limited Warranty and Remedy

Armstrong Hot Water Group, Inc. ("Armstrong") warrants to the original user of those products supplied by it and used in the service and in the manner for which they are intended, that such products shall be free from defects in material and workmanship for a period of one (1) year from the date of installation, but not longer than 15 months from the date of shipment from the factory [unless a Special Warranty Period applies, as listed below]. This warranty does not extend to any product that has been subject to misuse, neglect, or alteration after shipment from the Armstrong factory. Except as may be expressly provided in a written agreement between Armstrong and the user, which is signed by both parties, Armstrong **DOES NOT MAKE ANY OTHER REPRESENTATIONS OR WARRANTIES, EXPRESS OR IMPLIED, INCLUDING, BUT NOT LIMITED TO, ANY IMPLIED WARRANTY OF MERCHANTABILITY OR ANY IMPLIED WARRANTY OF FITNESS FOR A PARTICULAR PURPOSE.** The sole and exclusive remedy with respect to the above limited warranty or with respect to any other claim relating to the products or to defects or any condition or use of the products supplied by Armstrong, however caused, and whether such claim is based upon warranty, contract, negligence, strict liability, or any other basis or theory, is limited to Armstrong's repair or replacement of the part or product, excluding any labor or any other cost to remove or install said part or product, or, at Armstrong's option, to repayment of the purchase price. As a condition of enforcing any rights or remedies relating to Armstrong products, notice of any warranty or other claim relating to the products must be given in writing to Armstrong: (i) within 30 days of last day of the applicable warranty period, or (ii) within 30 days of the date of the manifestation of the condition or occurrence giving rise to the claim, whichever is earlier. **IN NO EVENT SHALL ARMSTRONG BE LIABLE FOR SPECIAL, DIRECT, INDIRECT, INCIDENTAL OR CONSEQUENTIAL DAMAGES, INCLUDING, BUT NOT LIMITED TO, LOSS OF USE OR PROFITS OR INTERRUPTION OF BUSINESS.** The Limited Warranty and Remedy terms herein apply notwithstanding any contrary terms in any purchase order or form submitted or issued by any user, purchaser, or third party and all such contrary terms shall be deemed rejected by Armstrong.

Special Warranty Periods are as follows:

Sense™ DMV is covered by a 5-year warranty against defects in materials or workmanship from the date of purchase/shipment. Armstrong reserves the rights to replace either the complete product, certain components of the product and/or replacement internal operating parts.

*Designs, materials, weights and performance ratings are approximate and subject to change without notice.
Visit armstronginternational.com for up-to-date information.*



Armstrong International
221 Armstrong Blvd., Three Rivers, Michigan 49093 - USA
Ph: (269) 279-3602 Toll Free: (888) HOT-HOSE (468-4673) Fax: (269) 279-3130

AHWG-700-A
AHWG 700
Printed in U.S.A. - 5/12