

DIMENSIONS & DATA CERTIFIED FOR:

Representative:

Order:

Customer:

Order:

Project:

Requirements:

By:

Date:

DIMENSION	A	B
6" FILL HEAD	55	64
12" FILL HEAD	61	70
18" FILL HEAD	67	76
24" FILL HEAD	73	82
36" FILL HEAD	85	94

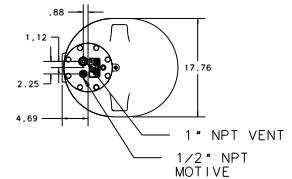
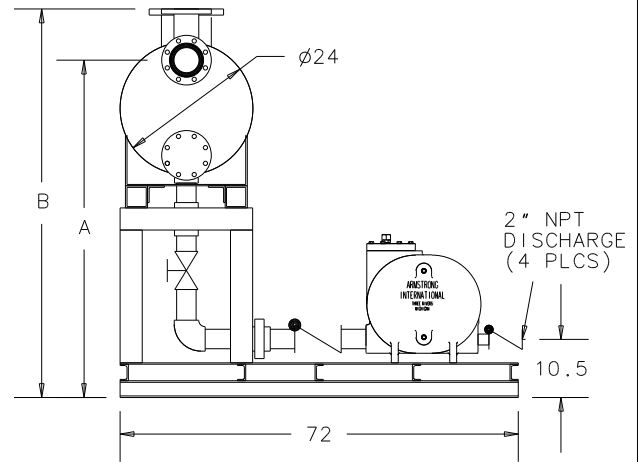
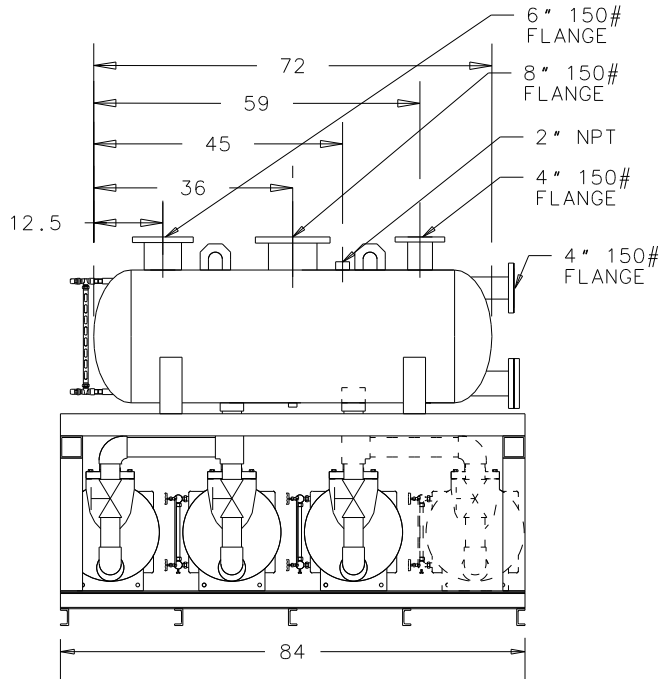

NOTES

1. RECEIVER ASME CODE STAMPED FOR 150 PSI
2. APPROX RECEIVER VOLUME 130 GAL
3. DRAWING SHOWS OPTIONAL GAUGE GLASSES



Armstrong Fluid Handling, Inc.

Three Rivers, MI. 49093

Telephone (269) 278-6500

Fax (269) 279-3150

Posted on Armstrong's homepage www.armstrong-intl.com

Product	CDF No.	Date
TPT/QPT 3500RP	CDF 1061	2/24/03
		Rev. A

LIST OF MATERIALS	
NAME OF PART	MATERIAL
RECEIVER TANK	CARBON STEEL
RECEIVER TANK SUPPORT	CARBON STEEL
RECEIVER BASEPLATE	CARBON STEEL
ISOLATION VALVES	BRONZE ASTM B62
CHECK VALVES	BRONZE ASTM B62
PIPING	CARBON STEEL ASTM A120/53
FITTINGS	MALLEABLE IRON ASTM A197 GRADE 150
BODY	ASTM A48 CLS 30 CAST IRON
COVER PLATE	SA-516-70 STEEL
CAP GASKET	COMPRESSED NON-ASBESTOS
BOLTS	SA-449 STEEL
INLET VALVE ASSEMBLY	STAINLESS STEEL
VENT VALVE ASSEMBLY	STAINLESS STEEL
VALVE ASSEMBLY WASHERS	ZINC PLATED STEEL
PLUG	STEEL
MECHANISM ASSEMBLY (INCLUDING FLOAT)	STAINLESS STEEL
MECHANISM SPRING	INCONEL X-750

OPTIONS	
1.	BRONZE GAUGE GLASS FOR: A) RECEIVER TANK B) PUMPING TRAPS. MAXIMUM ALLOWABLE PRESSURE 200 PSIG. THIS EXCEEDS PUMPING TRAP DESIGN OF 150 PSIG AT 425F
2.	INSULATION JACKET REMOVABLE AND REUSABLE 1 INCH THICK, 11# DENSITY FIBERGLASS MAT WITH JACKETING OF TEFLON COATED FIBERGLASS CLOTH. ALL HARDWARE OF T-304 STAINLESS STEEL.
3.	DIGITAL CYCLE COUNTERS
4.	STAINLESS STEEL CHECK VALVES

 Armstrong Fluid Handling, Inc. Three Rivers, MI. 49093 Telephone (269) 278-6500 Fax (269) 279-3150 Posted on Armstrong's homepage www.armstrong-intl.com		
Product	CDF No.	Date
TPT/QPT 3500RP	CDF 1061	2/24/03
		Rev. A