

DIMENSIONS & DATA CERTIFIED FOR:

Representative:

Order:

Customer:

Order:

Project:

Requirements:

By:

Date:

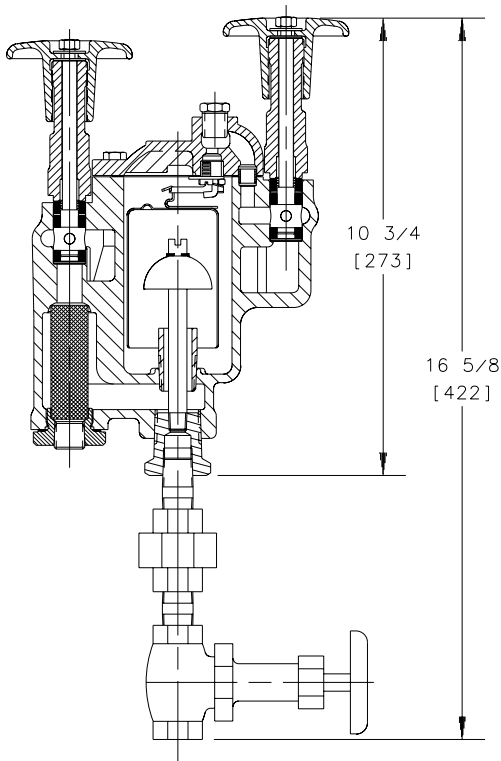
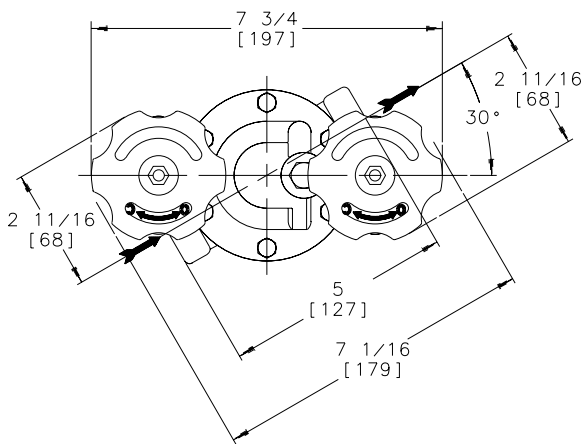

2-FRONT

NAME OR PART	MATERIAL
CAP AND BODY	ASTM A48 CLASS 30
INLET TUBE	STEEL PIPE
GASKET	COMPRESSED NON-ASBESTOS
BOLTS	CARBON STEEL
VALVE & VALVE SEAT	HARDENED STAINLESS STEEL
VALVE RETAINER	STAINLESS STEEL
LEVER	STAINLESS STEEL
GUIDE PIN ASSEMBLY	STAINLESS STEEL
BUCKET	STAINLESS STEEL
BODY THIMBLE	STAINLESS STEEL
INTEGRAL STRAINER	STAINLESS STEEL
BUSHING	STEEL
STRAINER BUSHING GASKET	SOFT STEEL
HANDWHEEL	ASTM A47-32510 CAST IRON
BONNET	ASTM A48 CL. 30
BONNET BOLTS	CARBON STEEL
WASHER	AISI 304L STN. STL.
NUT	AISI 304L STN. STL.
VALVE PLUG	Z6 CDF 18.02 STN. STL.
DISC SPRING	Z12 CN 17.07 STN. STL.
VALVE WASHER	AISI 304L STN. STL.
VALVE RING	GRAPHITE AND STN. STL.
LANTERN BUSHING	AISI 304L STN. STL.
MANUAL METERING VALVE	BRONZE & STN. STL.

PIPE CONNECTIONS	1/2 & 3/4
SECONDARY STEAM CONN.	3/8
MAXIMUM ALLOWABLE PRESSURE (VESSELE DESIGN)	250 psig at 450°F
MAX. OPERATING PRESSURE (psi)	250
WEIGHT:	13-1/2 LBS.

OPTIONS	
CONNECTIONS - NPT OR BSPT	<input type="checkbox"/>
* INTEGRAL STRAINER	<input type="checkbox"/>

3-RIGHT

 Armstrong International, Inc.
 Three Rivers Division
 Three Rivers, MI 49093
Armstrong (616) 273-1415 Fax(616) 278-6555
 Posted on Armstrong's homepage www.armstrong-intl.com

Product	CD No.	Date
TVS81DC		5/26/98
WITH MANUAL	CD1088	Rev. A
METERING VALVE		