

DIMENSIONS & DATA CERTIFIED FOR:

Representative:

Order:

Customer:

Order:

Project:

Requirements:

By:

Date:

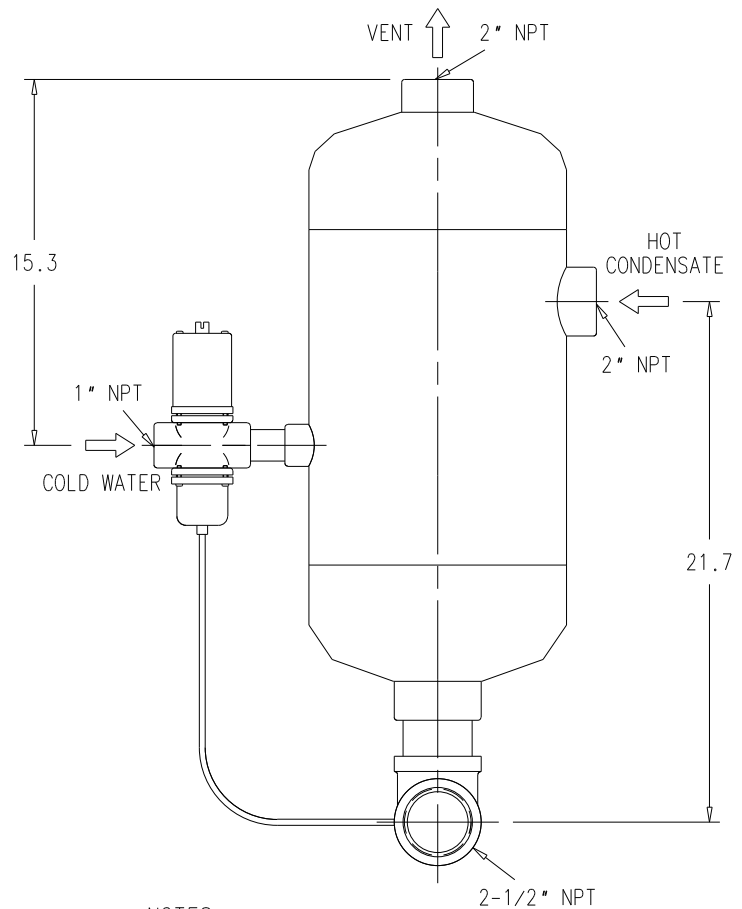
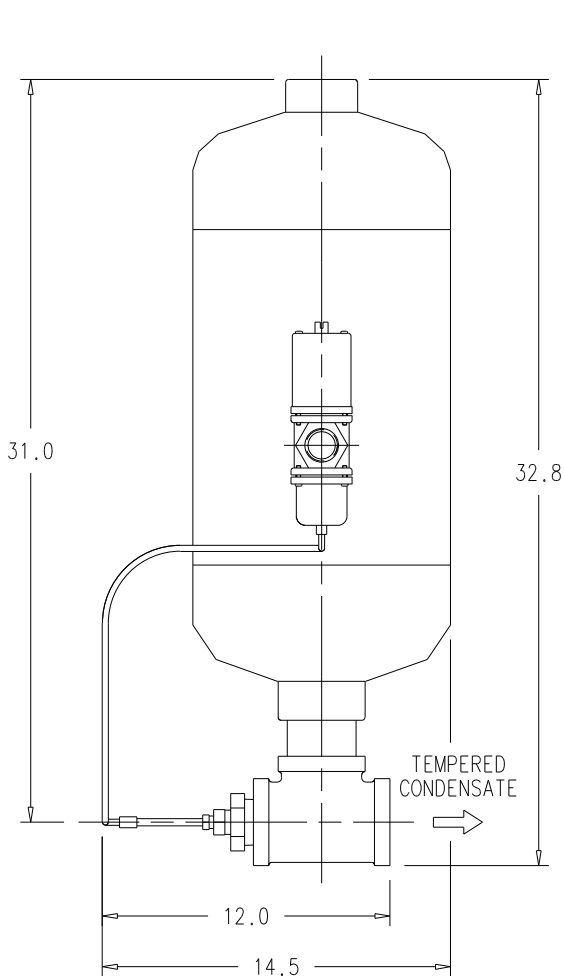

NOTES:

1. Tempered Condensate Range:
 Factory Set 135°F [57°C]
 Field Set 115 To 180°F [46 To 82°C]
2. Capacity:
 40 GPM w/180 °F Condensate

LIST OF MATERIALS	
BODY	Carbon Steel ASTM A106 Sch. 40
PIPE & FITTINGS -CONDENSATE -COLD WATER	Malleable Iron
BODY (CONTROLLER)	Brass
SENSING BULB	Bronze

ARMSTRONG HOT WATER GROUP
 221 Armstrong Boulevard
 Three Rivers, MI 49093
 Phone No. 1-269-279-3600 Fax 1-269-273-8656
 Posted on Armstrong's homepage www.armstrong-intl.com

CONDENSATE COOLER CC-40	Date 11/3/04	Rev. D
	Drawing No. CDY 1092	