

# Python® 1100 Series Control Valves

## Electric Actuators

### Installation and Operation Manual

IB-651



# Installation and Set Up Overview

 **Warning:** *This bulletin should be used by experienced personnel as a guide to the installation and maintenance of the Armstrong Python Electric Actuator. Selection or installation of equipment should always be accompanied by competent technical assistance. We encourage you to contact Armstrong or your local representative if further information is required.*

©2011 Armstrong International, Inc. Designs, materials, weights and performance ratings are approximate and subject to change without notice.

<b>Python® 1100 Series Overview.....</b>	<b>3</b>
<b>Product Information.....</b>	<b>4</b>
<b>Description.....</b>	<b>6</b>
<b>Installation and Dismantling.....</b>	<b>10</b>
<b>Adjusting of Actuator.....</b>	<b>12</b>
<b>Procedures.....</b>	<b>14</b>
<b>Service and Maintenance.....</b>	<b>18</b>
<b>Troubleshooting.....</b>	<b>20</b>
<b>Enclosure.....</b>	<b>24</b>

# Python® 1100 Series Overview



## 1. Safety Instructions:

**DO NOT use AEL as a lifting mechanism!**



**Important:** Requirements for professional qualification of people performing installation, service and maintenance: Electric connection should only be performed by qualified electricians or electrical engineers. Service and connections should only be performed by qualified electricians or electrical engineers.

## 2. Purpose and Application

Electric linear actuators (AEL) with electronic control of the AEL type are set up by the program to be controlled on the 24 V DC voltage level, or are set up by the program to be controlled by 4-20mA analog input signal.

Electric linear actuator type AEL are high-powered electric-mechanical products designed for direct installations onto controlled devices (regulating bodies - valves, etc.). AEL type actuators are provided for automatic control of regulating bodies in both directions of their movement. They are equipped to measure and control processes where an unified analogue direct current is needed.



## 2.2 Warning for safety use

Product protection:

There must be a suitable protective device in the supply power (circuit breaker or fuse) which also serves as the main switch. The AEL has its own short-circuit protection for the motor power supply circuits and space heater. Type of equipment from a connection point of view: The equipment is designed for permanent connection.

## 2.3 Data Specified on Electric Actuator

Name Plate:

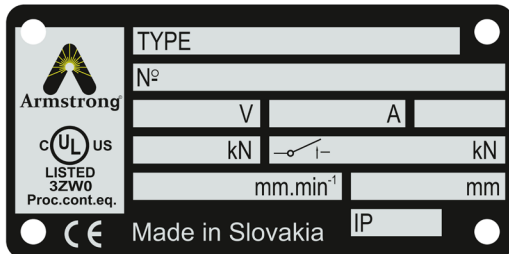

Warning Plate:

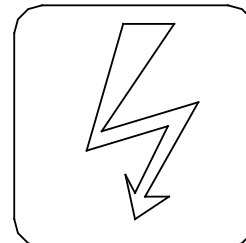

## Graphic Symbols on Electric Actuator



Dangerous voltage  
(5036 IEC 60417)



Switching- off thrust

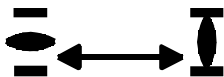

Stroke of the electric  
linear actuator



Manual control  
(0096 ISO 7000)

# Product Information

## ■ 3. Product Location and Operation Position

- The assembly and operation of an AEL can be in covered places or in industrial applications without the regulation of temperature, humidity and should have protection against direct exposure of climate influence (e.g. direct sun shine).
- Electric actuators must be placed with access to the manual handle (5), Fig.4 and Fig.6, to the cover of control box, to control box, to cable glands, to local electric control.
- Installation and operation of actuators can be installed in either vertical or horizontal position.

 **Warning:** *Actuator installed in an open place must be protected against direct climate effects by shelter, mainly from sunshine.*

## ■ 3.1 Power Supply and Operation Modes

Power Supply:

Electric motor.....	110/120 V AC, 220/230/240 V AC, resp.24 V AC ±10%
Control.....	binary inputs 24 V DC ±10%
.....	input control signal 0/4 up to 20, resp. 20 up to 0/4 mA
Electronic positional transmitter (EPV) without power supply (passive).....	18 up to 30 V DC ±10%
Frequency of power supply.....	50/60* Hz ±2%

\*At frequency of 50 Hz operating speed is decreased by 1.2 times.

**Duty cycle** - according to EN 60034-1, 8 (IEC 60034-1, 8):

AEL is designed - **for remote control**:

- Short-time operation S2-10 min
- Intermitted operation S4-25%, 6 up to 90 cycles per hour.
- Intermitted operation S4-25%, 90 up to 1200 cycles per hour.

## ■ 3.2 Product Description

The AEL electric actuator is controlled by 24 V DC voltage fed to the electric actuator's terminals according to the wiring diagram, or by 0/4 ÷ 20 mA (0/2 up to 10 V) (input control signal and provides for moving the output part of the EA automatically to a position corresponding to the value of the input signal) and other functions as well.

The electric actuator consists of these main parts (Fig. 1):

- The electric actuator is driven by an **electric motor (1)** supplied and controlled from the **source board (3)** and **control unit (2)**.
- Position of output element of AEL is scanned by **contactless absolute sensor**. Thrust is scanned with thrust switches S1 and S2.
- Depending on the version, the electronic circuit board may include **an electronic position transmitter (EPV)** without power supply (passive) with output signal 4 through 20 mA.
- **Space heater (5)** is placed at the control board.
- In case of power cut or damage of switches the actuator can be controlled by **manual handle** according to instructions stated in section 6 Service and Maintenance on page 19.

# Product Information, Continued

Figure 1	
1	Electric motor
2	Control unit
3	Source board
4	Position scanning unit
5	Space heater
6	Thrust Unit
7	LED display
8	Additional Relay

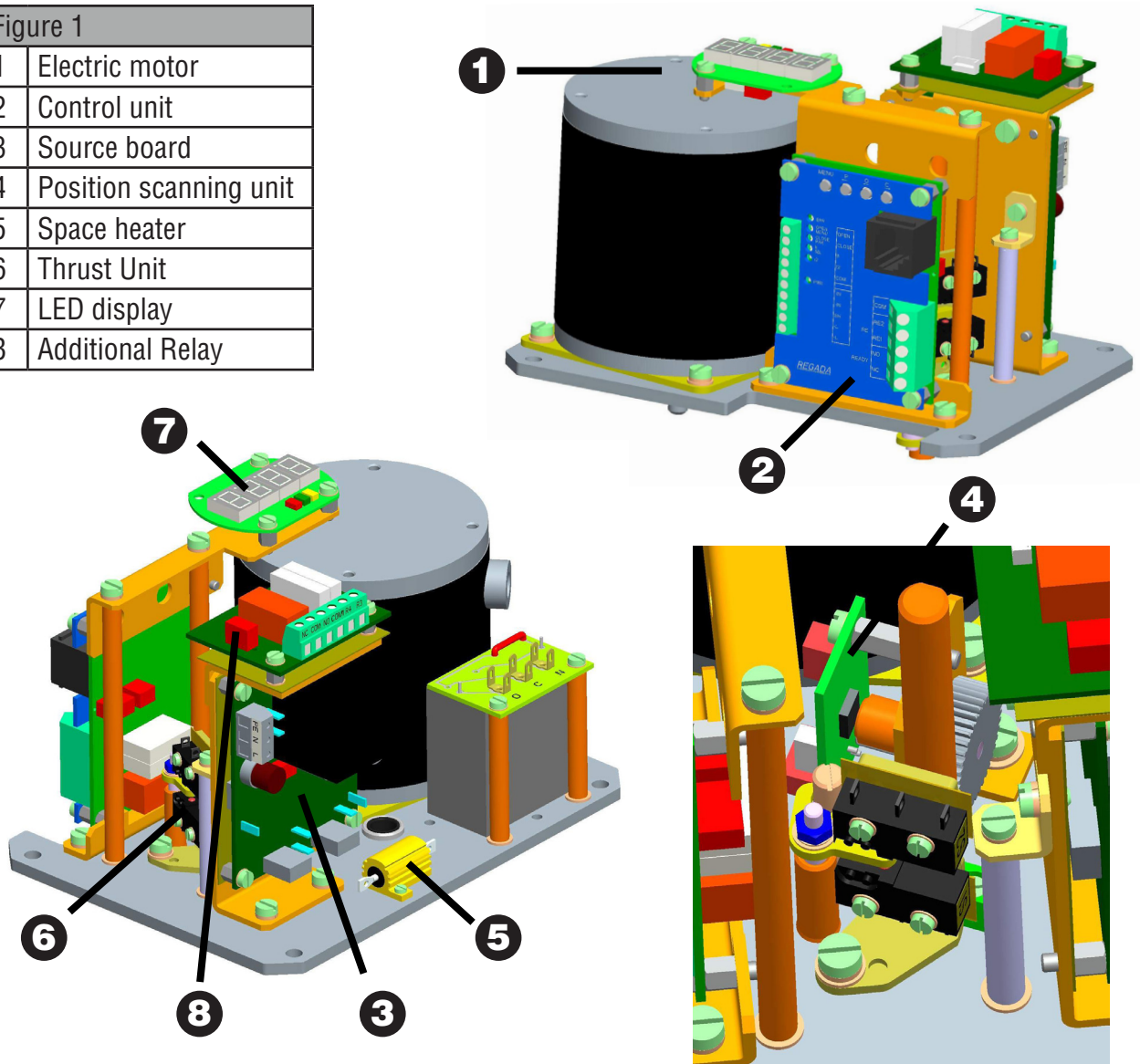

## Basic Modules of Electronic Control System for the AEL

- **Control unit (2)** – main part of system – it contains microprocessor, 6 signal LED and 4 buttons for simple adjustment and control of AEL, connectors for connection of thrust scanner and sourcing board and communication connector (connection to PC for adjustment and diagnostic), 2 free programmable relays RE1 and RE2, 1 relay READY and terminals for electric connection.
- **Sourcing board (3)** for single-phase version – secures power supply of electronic and provides an output voltage of 24 V DC, 40 mA for the user, it contains user terminal board, switching circuits, connector for connection with control unit.
- **Position scanning unit (4)** – secures contactless magnetic position scanning of output element.
- **LED display (7)** – shows instant position of AEL output member and reports and displays potential errors, which would occur when AEL is operated. Signalling motion and failure of the AEL is also indicated by LEDs diode. LED display is only used on AEL without local control.
- **Manual control:** manual handle on the upper cover of the AEL.
- Other optional accessories:
  - Additional relays module R3, R4, R5 (8).
  - Local electric control module equipped with 2-line LCD display (7).

# Description

## Electric Control:

Remote control: movement of output part of the electric actuator is controlled:

By binary inputs 24 V DC, or by unified input signal 0/4 - 20 mA resp. 0/2 - 10 V (depending on the model).

## Power supply of electronics:

Power supply Z2 is used for single phase versions and feeds the electronic modules built in the AEL. It provides the 24V DC, 40 mA output voltage.

Power sources contain a protective fuse with parameters according to section 7 Troubleshooting on page 20.

**Position scanning:** no contact, absolute magnetic.

## End positions adjustment:

End position relays are adjusted to the specified stroke with accuracy of  $\pm 0.5\text{mm}$ .

It is possible to set it up (with buttons situated on the control unit, with buttons situated on the local control, program after connecting the AEL with PC) the shutting off in end positions as follows:

Z=	Torque + 0	Torque
Z=	Torque + 0	Position
Z=	Position + 0	Torque
Z=	Position + 0	Position

Notes:

C=	Torque	shutting off at end limit	Thrust	Closed
O=	Torque	shutting off at end limit	Thrust	Opened
C=	Position	shutting off at end limit	Position	Closed
O=	Position	shutting off at end limit	Position	Opened

Factory's setup of shutting off in end positions is described in section 6 Adjusting of Actuator on page 18.

## Thrust scanning:

Remote control: movement of output part of the electric actuator is controlled:

By binary inputs 24 V DC, or by unified input signal 0/4 - 20 mA resp. 0/2 - 10 V (depending on the model).

## Thrust switches adjustment:

Thrust switches switch-off in the interval stated in the Specification table and they cannot be adjusted by user.

## Thrust blocking:

The switching-off from thrust can be blocked within a certain range of the stroke starting from a stroke end position (maximum 5%), for time agreed on, in range of 0 to 20 seconds.

## Output relay :

- 3x relays (standard) (READY, RE1, RE2) max. 250 V AC/1 A/cos phi=1; max. 30 V DC/2A
- 3x additional relays (options) (R3, R4, R5) max. 250 V AC/1 A/cos phi=1; max. 30 V DC/2A
- Relays READY, RE1, RE2, R3, R4 and R5 are free programmable (their function can be changed with buttons on the control unit, with buttons on the electric local control, or through a PC with the program).

**READY** relay: - program selection options – error indication, error or warning, error or not remote, error or warning or not remote. READY relay factory set is shown in the section 6 Adjusting of Actuator on page 18.

**RE1 and RE2, R3, R4 and R5 relay: - program selections option** – disabled, Position O (position open), Position C (position close), Torque O (torque open), Torque C (torque close), Torque O or Torque C, Torque O or Position O, Torque C or Position C, opens, closes, movement, movement – flasher, to position, from position, warning, control – remote, control – local, (not valid for EA without local control), control OFF. R3, R4, R5 relays are independent. Factory setting up of the individual relays is shown in the section 6 Adjusting of Actuator on page 18.

# Description, Continued

## Transmitter (output signal)

Electronic position transmitter (EPV) passive (for single phase versions)- 2-wire connection (without inbuilt power supply).

Current signal.....	4 ÷ 20, 20 ÷ 4 mA, 24V (DC)
Voltage at connection of EPV passive.....	18 up to 30 V DC
Load resistance.....	max. RL= 500 Ω
Tolerance of value of output signal of electronic transmitter in end positions: .....	±0,5 % <sup>1)</sup>
Tolerance of linearity of transmitter.....	±1 [%] <sup>1)</sup>
Hysteresis of transmitter.....	max. 1 [%] <sup>1)</sup>

<sup>1)</sup> from nominal value of transmitter referred to output values

Program possibilities of output signal: 4 ÷ 20 mA, 20 ÷ 4 mA. Factory's setup of output signal is described in section 6 Adjusting of Actuator on page 18.

## Electronic controller (N): actuation by input control signal

Input control signals - analogue.....	0 - 20 mA (0 – 10 V according to version)
.....	4 - 20 mA(2 – 10 V according to version)
.....	20 - 0 mA(10 – 0 V according to version)
.....	20 - 4 mA(10 – 0 V according to version)
Input resistor for signal 0/4 up to 20 mA.....	Rin = 120 Ω
Input resistor for signal 0/2 up to 10 V.....	Rin = 3 kΩ
Tolerance of controller's linearity:.....	0,5 %
Dead band of controller:.....	program adjustable within 1 - 10%

Factory's setup of input signal is described in section 6 Adjusting of Actuator on page 18.

## Control by binary inputs 24 V DC by feeding of 24 V DC to terminals CLOSE and OPEN

### Programming possibilities of binary inputs I1 and I2\*

Change is possible only through the program of a PC or using buttons on the local control

- **For the input I1:** DISABLED; ESD; DBL (local releasing - not valid for AEL without local control), STOP
- **For the input I2:** DISABLED; ESD; DBL (local releasing - not valid for AEL without local control), 2P (the AEL can undergo control for the opening direction or closing with the controller ON and I2 input activated with 24 V DC voltage supplied to the terminals to OPEN or CLOSE).

### Programmable FAILURE REACTION : OPEN, CLOSE, STOP, SAFE POSITION

Factory's setup can be found in section 6 Adjusting of Actuator on page 18.

### Adjustable elements of electronics:

The AEL is possible to adjust with or resetting to different parameters operating the control unit buttons, or with buttons on the local control (according to version), or once it is connected to the PC using the program and the communication cable connected to the AEL control unit communication connector and the AEL cover removed.

### Space heater (E1)

Space heater - supply voltage.....	corresponding with motor supply voltage (max. 250 V AC)
Space heater power output.....	cca 10 W/55°C (131°F)

**Manual control:** with manual handle on the upper cover of the AEL. Turn the manual handle clockwise to move the output shaft of the AEL in the direction "Z – closed".

**Output part clearance**.....max. 0, 5 mm (at 5 % of maximum thrust load)

**Grease:** see section 6 Service and Maintenance on page 19.



# Description, Continued

## ■ 3.3 Mechanical Connection

- Pillars
- Flanges

Main and connecting dimensions are given in the dimensional drawings

## ■ 3.4 Electric Connection

- 3 terminals (PE, N, L) on the sourcing board with intersection of connection wire 0,05 - 1,5 mm<sup>2</sup> for solid wire and for flexible wire. Maximum terminal screw tightening torque 0,5 Nm.
- 2 terminals (0 V,+ 24 V) with intersection of connection wire 0,05 – 1,0mm<sup>2</sup> for solid wire and for flexible wire. Maximum terminal screw tightening torque 0,19 Nm.
- 5 terminals (READY, RE1, RE2) with intersection of connection wire 0,05 – 1,5 mm<sup>2</sup> for solid wire and for flexible wire. Maximum terminal screw tightening torque 0,5 Nm.
- 10 terminals (COM, CLOSE, OPEN, I1, I2, +IN,-IN,SH,+L,-L) with intersection of connection wire 0,05 – 1 mm<sup>2</sup> for solid wire and for flexible wire. Maximum terminal screw tightening torque 0,19 Nm.
- 6 terminals (COM1, R3, R4, R5 COM, NO, NC, for RELE R5) - for module additional relays with intersection of connection wire 0,05 – 1,5 mm<sup>2</sup> for solid wire and for flexible wire. Maximum terminal screw tightening torque 0,5 Nm.



**Attention!** Thermic resistance incoming wires must be minimum 176 °F (+80°C)

Wire cross-section conversion table (mm <sup>2</sup> - AWG)	
Wire cross-section	
mm <sup>2</sup>	AWG
0,05	30
0,2	24
0,34	22
0,5	20
0,75	18
1,5	16
2,5	14

Tightening torque conversion table (N.m - lbs. - in)	
Tightening torque	
N.m	lbs.in
0,2	2,7
0,3	4
0,5	7

### Cable glands:

- 1 cable gland M20x1,5 - cable diameter from 8 to 14,5 mm.
- 2 cable glands M16x1,5 - cable diameter from 6 to 10,5 mm.



# Description, Continued

## ■ Protection Terminal:

During start-up - during installation of device:

- Outside and inside ground terminal must be connected for safe operation of the actuator. The position of the outside and inside ground terminal can be seen in **Figure 2** and **Figure 2a**.
- A switch or circuit breaker must be installed on the power supply line, as close as possible to the device, easily accessible to operators and identified as the actuator isolation switch.

Outside and inside are connected together and marked with the mark of protection grounding. The electric connection should be made according to wiring diagrams pasted in the upper cover of the AEL.

## Fuses:

Actuator power supply board is installed with power supply fuse (**F3**). Location of the fuse on the power supply board can be seen in **Figure 2**.

## Fuse values and parameters:

Figure 2

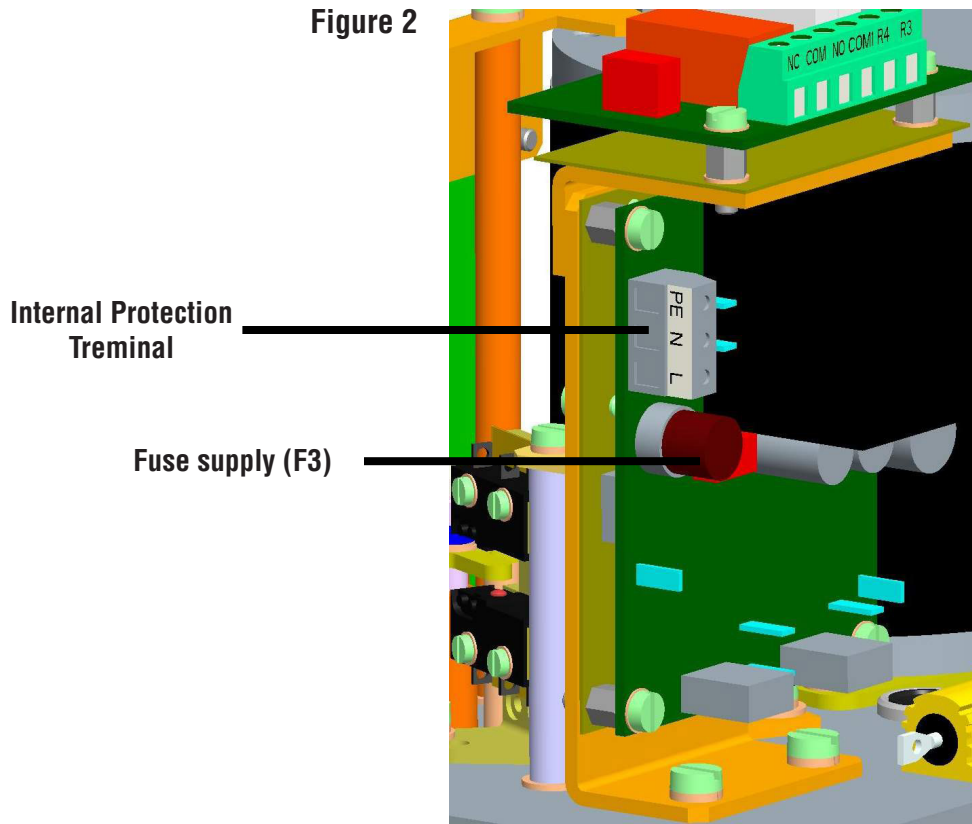
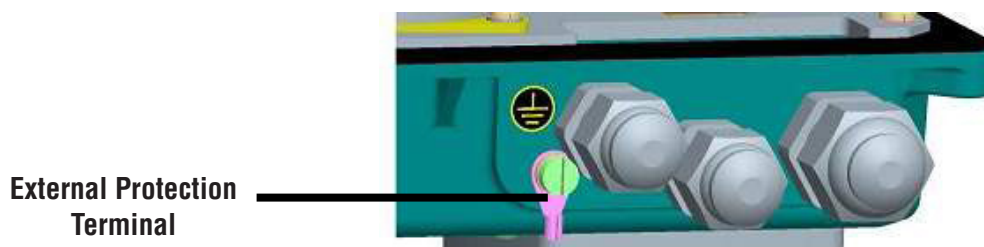

Figure 2a



# Installation and Dismantling

## ■ 4. Mechanic Connection of Electric Actuator to the Armature

AEL electric actuators can be assembled and operated in any position. During assembly care must be taken for the space for disassembly of upper cover and with the option to set up elements.

### Mechanical Connection for Version with Flange (Fig. 5)

#### Connection Procedure:

1. Check the labels to confirm the actuator and the valve strokes are the same.
2. Set the actuator (A) to mid-position and the valve (B) to the **CLOSED** position.
3. Put the actuator (A) onto the valve (B).
4. Screw the coupling nut (1) onto the valve output shaft (3) until the actuator flange (2) contacts the valve bonnet (4).
5. Connect the flanges by tightening the locking nut (5).
6. Unscrew the coupling nut (1) by one more revolution to the left and lock with the nut (6) to create the pre-load onto the valve seat.
7. Use the handle to have the actuator output shaft close to the valve shaft (3) and scare the coupling parts together.

Item No.	Description
A	Electric Actuator
1	Coupling Screw
2	Actuator Flange
B	Valve
3	Valve Shaft
4	Valve Bonnet
5	Central Nut
6	Lock Nut

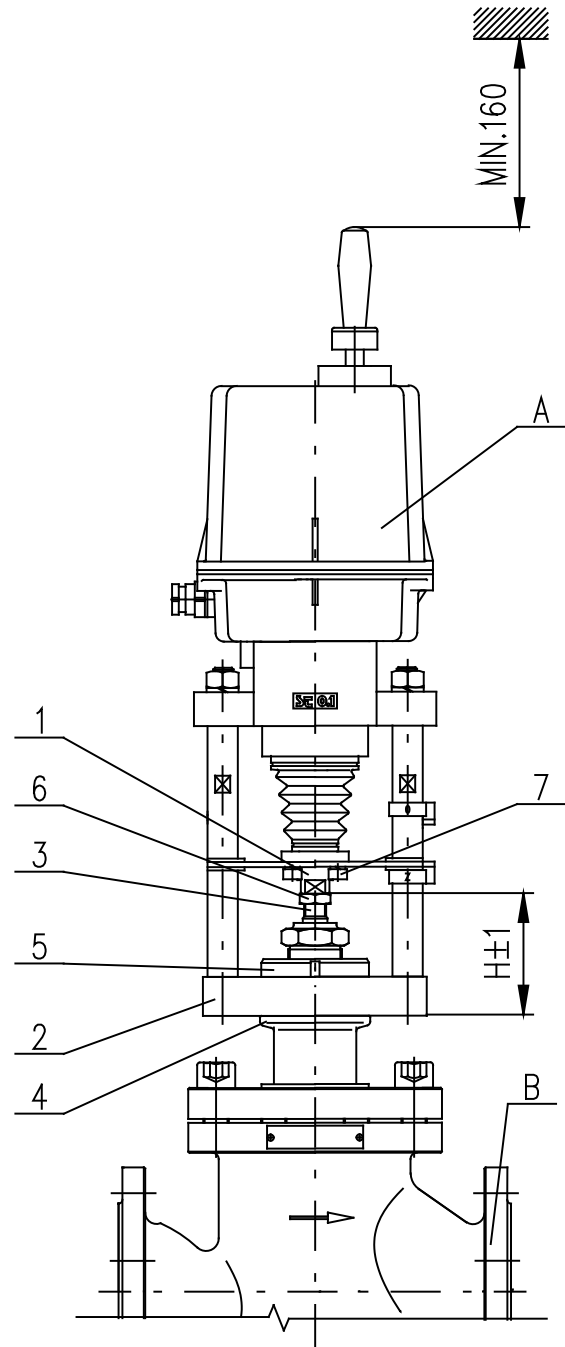

Fig.5

# Installation and Dismantling, Continued

## ■ 4.1 Electric Connection and Checking of Function

Follow up with connecting the AEL with mains or master system.

1. Follow instructions in section 2.2 on page 3.
2. While laying electrical line abide by the instructions for heavy current installations. Power supply cables must be of the type approved. Minimum thermal resistance of power supply cables and wires must be 176°F (+80°C).
3. Cables to terminal boards or connectors lead through cable glands.
4. Before putting AEL into operation, connect inside and outside grounding terminal.
5. Wires for input control signal to controller and output signals from current converter it is necessary to lead them separately with thrust wires or it is necessary to use shielded wires.
6. To prevent moisture from entering the actuator around the connecting cables, the cables must be sealed with silicone material at the point of penetration through device shell.

### Connecting with the master system:

AEL can be controlled by:

- Analog signals through the built-in controller.
- Binary inputs 24 V DC

*AEL is connected according to wiring diagram under the cover of the AEL.*

## ■ 4.2 Dismantling



***Before dismantling, you must disconnect the AEL from power supply! Do not connect and disconnect live connectors.***

**Step 1** Disconnect the AEL from the main electrical phases.

**Step 2** Disconnect the leads from the AEL terminal boards and loosen the cables from the cable glands.

**Step 3** Loosen the screws of the AEL flange and coupling and disconnect the AEL from the valve.

# Adjusting Actuator

## ■ 5. Adjusting Actuator

AEL is delivered adjusted to parameters according to type and label from production plant. Adjustment is made to mechanical and electrical connected actuator. This section describes how to set up the AEL to parameter values within a range applicable for the software. Location of adjustable parts are on **Fig. 7**.

### Adjustment is possible:

- By the control unit buttons (**see Fig. 7**)
- By the local control panel buttons – only for the AEL's equipped with local control
- PC program once the AEL is connected to the PC using the communication cable

For facilitating the simple setting of required operation parameters, the control unit is equipped with:

- Four setting buttons: **MENU, P, O, C**
- Six signal lamps according (LED diode) to **Fig. 7**

Status indication by LED diodes	
LED ERROR (red)	Blinks red in case of failure; eventually lights in the parameter setting mode
LED OPEN/MENU (green)	In the ON/OFF mode, it lights with a control action for the opening direction; eventually blinks when accessing the MENU mode
LED CLOSE/PAR (red)	In the ON/OFF mode, it lights with a control action for the opening direction; eventually blinks besides the chosen parameter in the menu and lights up when it's writing the parameter into the memory.
LED I1/SEL (yellow)	Permanent lights with active input I1, or flashes in the mode of parameters set up
LED I2 (yellow)	Permanently lights with active input I2
LED POWER (green)	It lights with power supply

Electronics: program selections option	
Relay RE1; RE 2	disabled; open position, close position, torque-open, torque – close, torque open or torque close, torque open or position open, torque close or position close, open, close, movement, movement flasher, to position, from position, warning, remote control, local control, control shut off.
Relay READY	errors, errors or warnings, errors or no remote, errors or warnings or no remote
Output Signal	(from EPV passive): 4 to 20 mA; 20 to 4 mA.
Control (regulating)	2P, 3P, 3P/2P I2
Input Control Signal (N)	4 to 20 mA, 20 to 4 mA, 0 to 20 mA, 20 to 0 mA
Input I1	DISABLED, ESD, DBL (local releasing - not valid for AEL without local control), STOP
Input I2	DISABLED, ESD, DBL (local releasing - not valid for AEL without local control), 2P (with active controller - to enable program control 3P/2P I2 - enables control by binary inputs 24V DC with active input I2).
FAILURE REACTION	OPEN, CLOSE, STOP, SAFE POSITION

Note: The identical functions cannot be set on I1 & I2 inputs in addition to the OFF state (i.e., if the ESD function is set on I1, it is not possible to select the ESD function on I2 input at the same time).

# Control Unit Button

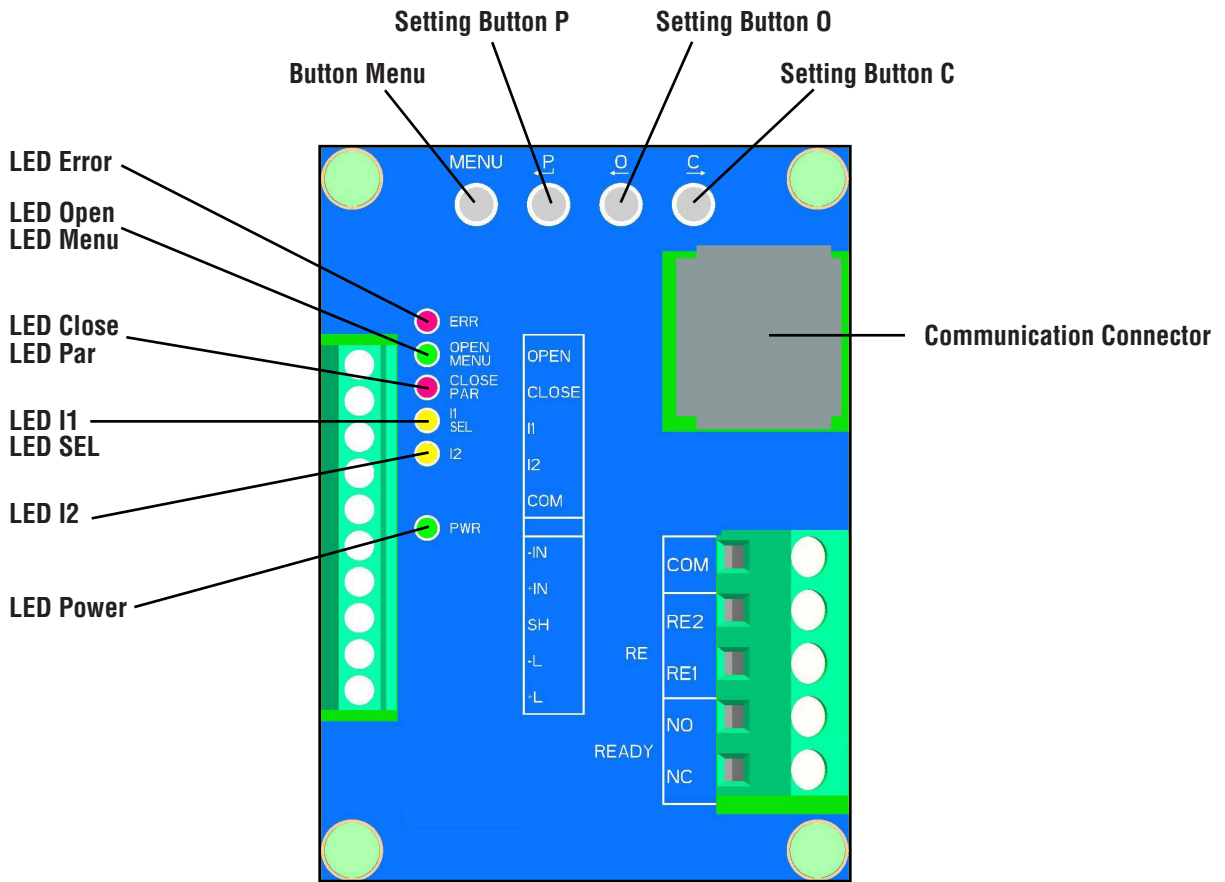

Figure 7

# Procedures

- 5.1 Procedure for setting individual parameters
- 5.2 The factory default setting of individual programs shown in Table 2 and Table 3, as long as otherwise specified by the customer:

<b>Table 2</b>			
Factory default settings of individual parameters in version without local control possible to set-up by operating the control unit buttons			
Menu	Name	Factory Setting-up	
1	TORQUE	100% of value shown on nameplate for OPEN & CLOSE	
2	END LIMIT	<ul style="list-style-type: none"> <li>- C = Position + O = Position - end position switching closed and open from position if valve type is not specified</li> <li>- C = Torque + O = Position - closed in end by thrust position and end position switching off from position for single-seat valves</li> <li>- C = Torque + O = Torque – switching in both end positions by thrust for double-seat valves</li> </ul>	
3	TORQUE BLOCKING	<ul style="list-style-type: none"> <li>- 2 sec. blocking time</li> <li>- 5% blocking position for OPEN &amp; CLOSE direction</li> </ul>	
4	RELAY READY	- errors (READY COM-NO relay contacts closed in error free conditions)	
5	RELAY 1...5	<ul style="list-style-type: none"> <li>- position O for relay RE1/R1</li> <li>- position C for relay RE2/R 2</li> <li>- from position 95% for relay R3</li> <li>- from position 5% for relay R4</li> <li>-disabled for R5 relay</li> </ul>	
6	CPT (output signal)	4 to 20 mA	
7	REGULATION (according to specification)	2P	3P
	ANALOG INPUT	-	4 to 20 mA (2 to 10 V)
8	DEAD ZONE	-	3%
9	FAILURE REACTION	STOP	

Other parameters set-up not possible to change without using the PC software	
TITLE	FACTORY SETTING-UP
THERMOSTAT TEMPERATURE	25° (space heater OFF temperature)
INTERNAL DEAD ZONE	2 % (only for 3P)
Safe position	0 %
FUNCTION I1	ESD
ACTIVE I1	high level
FUNCTION I2	DISABLED
ACTIVE I2	high level
THERMAL FUSE FAILURE	functionless with this AEL type
THERMAL FUSE RESET	functionless with this AEL type
CYCLE MODE	DISABLED
CYCLE RUNNING TIME	10s
CYCLE PAUSE	50s
CYCLE POSITION O1	0%
CYCLE POSITION O2	100%
CYCLE POSITION C1	0%
CYCLE POSITION C2	100%
O AND C TOLERANCE	1%
CREATE BACKUP	START
RESTORE FROM BACKUP	START
RESTORE FACTORY SETUP	START
ACTIVE ERRORS	CLEAR



**Table 3**

Factory default settings of individual parameters in version with local control; possibility to set-up by operating the local control buttons.

MENU	NAME	FACTORY SET-UP	
1	JAZ/LANGUAGE	English (select language on LCD display)	
2	POSITION O	work angle range set as per AEL specification	
3	POSITION C		
4	REG. CALIBR.	START	
5	END LIMIT	<ul style="list-style-type: none"> <li>- <b>C = Position + O = Position</b> – end position switching closed and open from position if valve type is not specified</li> <li>- <b>C = Torque + O = Position</b> – closed in end by thrust position and end position switching open from position for single-seat valves</li> <li>- <b>C = Torque + O = Torque</b> – switching in both end positions by thrust for double-seat valves</li> </ul>	
6	TORQUE O	100% of value shown on nameplate	
7	TORQUE C	100% of value shown on nameplate	
8	BLOCK. TIME	2 s	
9	BLOCK. POS. O	5%	
10	BLOCK. POS. C	5%	
11	CPT (output signal)	4 to 20mA	
12	REGULATION (according to specification)	2P	3P
13	ANALOG. INPUT	-	4 to 20mA
14	DEAD ZONE	-	3%
15	INT. DEAD Z.	-	2%
16	FAIL. REACT.	STOP	
17	SAFE POSIT.	0%	
18	FUNCTION I1	ESD	
19	ACTIVE I1	high level	
20	FUNCTION I2	DISABLED	
21	ACTIVE I2	high level	
22	THERMO. FAIL. (THERMAL FUSE FAIL)	functionless with this AEL type	
23	THERMO. RESET (THERMAL FUSE RESET)	functionless with this AEL type	
24	RELAY READY	error	
25	RELAY 1	Position O (POSITION OPEN)	
26	RELAY 1 POS.	0%	
27	RELAY 2	Position C (POSITION CLOSE)	
28	RELAY 2 POS.	0%	
29	RELAY 3	FROM POSITION	
30	RELAY 3 POS.	95%	
31	RELAY 4	TO POSITION	
32	RELAY 4 POS.	5%	
33	RELAY 5	DISABLED (OFF)	
34	RELAY 5 POS.	0%	
35	CYCLE MODE	DISABLED	
36	CYCLE RUN. T.	10s	
37	CYCLE PAUSE	50s	
38	OC TOLERANCE	1%	
39	INFORMATION	TORQUE	
40	RESTORE BACK.	START	
41	CREATE BACK.	START	
42	RESTORE FACT.	START	
43	ACTIVE ERR:	CLEAR	

Other parameters set-up not possible to change using the PC software	
NAME	FACTORY SET-UP
THERMOSTAT TEMPERATURE	77°F (25°C)(space heater OFF temperature)
CYCLE POSITION O1	0%
CYCLE POSITION O2	100%
CYCLE POSITION C1	0%
CYCLE POSITION C2	100%
LCD CONTRAST	0

**Warning 1:** When the input control signal is set to the value 0 20 mA (0 to 10 V), or 20 0 mA (10 to 0 V) and the input control signal fails, then the AEL keeps the position as with a 0 mA (0 V) input signal (AEL doesn't recognize the difference between input signal failure and 0 mA (0 V) input signal).

**Warning 2:** Auto-calibration process will not run when the AEL is in error state, e.g. AEL is overloaded (AEL is switched -off from torque). In this case it is necessary to resolve issue, e.g. the AEL must be moved manually in a neutral position so it is not switching-off from torque and restart the auto-calibration again.

**Warning 3:** Calibration process must be performed with any change in the operating angle value of more than 10%

**■ 5.3 Commissioning an AEL into Operation (starting the calibration)**

If the AEL is delivered from manufacturing plant installed on valve, or with control device, calibration should be performed to ensure correct operation under actual pipeline conditions.

**Procedure:**

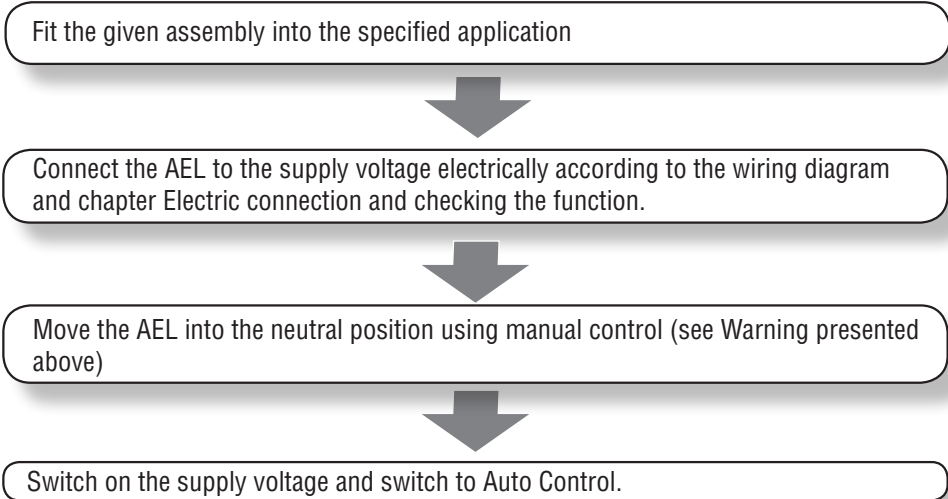

# Procedures, Continued

## ■ 5.4 Commissioning an AEL into operation when it's necessary to change the stroke (setting new end positions)

When an AEL is delivered without a valve or the actuator is changed to a different valve, and the setting of other parameters done by the producer suit your needs, and it is necessary to do a change to the AEL stroke.

Connect the AEL with the armature to be controlled (according to chapter 2) and fit this assembly into the specified application



Connect the AEL electrically according to the wiring diagram on page 25.



Turn on the power supply, **without connecting the control signals** fed into AEL (input control signal - AEL reports error/warning No.2 - no binary input)



Set the AEL using Manual Control to end position - closed. In Auto Control push button **C** for at least 2 seconds, until LED ERROR (red), LED MENU (green) and LED PAR (red) come on – the closed end position is then recorded in memory.



**Release** the **C** setting button



Set the AEL using Manual Control to end position - opened. In Auto Control push button **O** for at least 2 seconds, until LED ERROR (red), LED MENU (green) and LED PAR (red) come on – the opened end position is then recorded in memory.



**Release** the **O** setting button



Using **Manual Control** put the AEL into the mid position (see Warning 2 above)



In **Auto Mode** press the **P** pushbutton on the control unit for **at least 2 seconds**. This will activate the AEL calibration until LED ERROR (red), LED MENU (green) and LED PAR (red) come on



Release the adjustment pushbutton **P** - upon release of the **P** pushbutton, the calibration process has started



Turn on the control signals, AEL is ready for operation and responds to control inputs

# Service and Maintenance

## ■ 6. Service and Maintenance

 In general it is provided that service of the AEL is performed by a qualified electrician in accordance with requirement given in section 1 on page 3!

At a power outage, an electric actuator will stop in a position, in which it had been before the power outage occurred. It's possible to preset the electric actuator with manual operation.

### Manual control:

If needed (during adjusting, function checking, failure etc.) control can be changed from automatic to manual by switching the side handle to the hand position.

- Instructions for manual control:
- Switch the power supply off.
- Turn the button for gear disengagement to the right by 90° (Fig. 11, the button arrow shows the symbol of hand) this disengages the gear in the actuator.
- Set the actuator to the chosen position:
  - a) For actuators **with** manual control: push and turn the handle located on the actuator upper cover. While turning counter-clockwise the valve is turning in the direction “open”. Having the valve in the required position turn the button for gear disengagement to the position “automatic operation” this engages the gears<sup>1)</sup>. Put the handle back to its original position.
  - b) For actuators **without** manual control - using the fork wrench. Remove top cover, put fork wrench on 6-edged shaft of manual control. While turning counter-clockwise the valve is turning in the direction “open”. After resetting of the valve put the gear disengagement button to the original position<sup>1)</sup> and cover the actuator.

<sup>1)</sup>After putting the button for disengaging of gearing again to the position of motor operation if the gearing is not connected it is needed to turn the handle to put the gears into mesh.

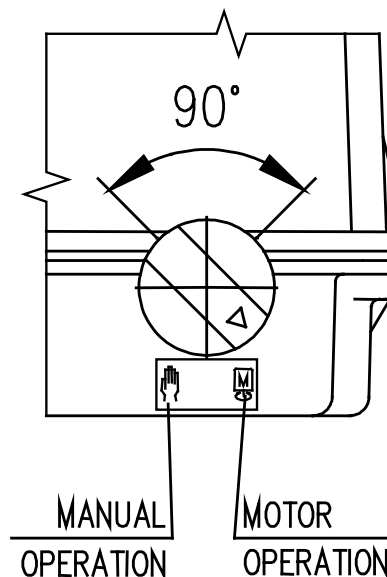

**Fig. 11**

# Troubleshooting

## ■ 7. Troubleshooting

At failure of power supply the AEL stops in the position where it was before the failure. If needed the AEL can be set only with the manual control (the hand wheel). After restoration of power the AEL is prepared for operation.

**Note 1:** In some cases to remove an error, you should turn off the power supply for 3 seconds.

**Note 2:** One of the possible errors may be failure to return disengagement button after the manual control to the position mechanical control, in such case, the AEL will remain standing.

- If AEL elements fail, it can be replaced with a new one. The producer's service centre only is allowed for such replacement.
- If AEL fails, proceed please according to the instructions for the under guarantee and after-guarantee
- For repairing eventually the electronics use the fuse – see Fig.2 (F3) for example SHURTER MSF 250, or sub miniature SIBA 164550 xxx (see chapter 1.9.2), which is located on source board.

Code	Name	Warning <sup>1</sup>	Error <sup>1</sup>	Reason	Reparation
1	ESD	X	-	Input ESD Activated	1. Deactivate input ESD 2. Check the wiring
2	Analog control signal	X	-	Analog control signal is <2,5 mA	1. Connect the control signal correctly to the connector +IN -IN 2. Check the regulation parameter. If the analog control signal is disabled regulation parameter must be set to the 2P mode. 3. Check the control signal using some multimeter. 4. Check the parameter analog control signal. If the signal is 0 – 20mA then parameter must be set respectively. 5. Recalibrate input of control signal. It means parameter 1mA and 20mA.
3	Calibration	-	X	Calibration starts when torque is activated	1. Move the actuator to the position when torque is not activated.
4	Torque	-	X	Torque was activated outside the end positions.	1. Check the end limit position 0 and C. End limit position must be set between torque values. 2. Check if there is some mechanical obstacle.
6	Thermofuse	-	X	Overheating is activated.	1. Wait until motor is cooled down. 2. Check the wiring.
7	Direction	-	X	Sense of rotation is reversed.	1. Check the sense of rotation of position sensor. 2. Check the right wiring of the motor. 3. Check the right connection of phases when three-phase motor is used.
8	EEPROM	X	-	CRC of EEPROM does not match.	1. Record any parameter without changing its value.
9	RAM	-	X	CRC of RAM does not match.	1. Reloading parameters will automatically repair this error. 2. If the error occurred repetitively send the control unit to manufacturer.
11	Menu Mode	X	-	Systems is in menu.	1. Exit the LCD or LED MENU. 2. Exit the setting mode in EHL explorer, e.g. after manual control of motor. 3. Turn off and on the power line.
12	Torque sensor	-	X	Systems is in menu.	1. Change the broken gearbox of the torque sensor. Magnet must be in specified distance from the sensor and must have specified strength of magnetic field. 2. Replace the broken torque sensor.

Code	Name	Warning <sup>1</sup>	Error <sup>1</sup>	Reason	Reparation
13	Sensor of position 1	-	X	Error of position sensor 1	1. Check the mounting of position sensor. 2. Replace the position sensor module. 3. Replace the gearbox of position sensor module.
14	Sensor of position 2	-	X	Error of position sensor 2	See code nr. 13
15	Sensor of position 3	-	X	Error of position sensor 3	See code nr. 13
16	Sensor of position 4	-	X	Error of position sensor 4	See code nr. 13
17	Regulator calibration	X	-	Unexecuted	1.Start regulator calibration.
18	Torque calibration	-	X	Wrong settings of torque values.	1. Backup the parameters from system backup or from file. 2. Torque calibration.
19	Stroke	-	X	Wrong settings of stroke value.	1. Reset the parameters Position C and Position O. New values must meet the required range.
21	Temperature <	X	-	Temperature is too low.	1. Check the parameter Temperature min. 2. Check the value of current temperature. 3. Check the function of heating.
22	Temperature >	X	-	Temperature is too high.	1. Check the parameter Temperature max. 2. Check the value of current temperature.
26	Buserror	-	X	Buserror	1. Check the wiring between all modules. 2. Disconnect the bus cabel from control unit. If the error is still active replace the control unit. 3. Connect only the bus cabel and disconnect from it all modules. If the error occurred, replace the bus cabel. 4. Consecutively connect particular modules. After each one check if the error occurred.
28	Phase	-	X	Missing phase or wrong sequence of phases	1. Check the voltage of each phase and also the voltage between all phases. 2. Switch any two phases.
29	Relay	X	-	Operating life of relay overflow.	1. Replace the relay and clear the counter Sum engine O contacts and Sum engine C contacts.
31	ROM	-	X	Wrong CRC of ROM	1. Turn off and on the power line. If the error appears again send the control unit to the manufacturer.
33	Wrong command	-	X	Inputs O and C are active simultaneously.	1. Check the function of superior system.
34	Inertia	-	-	Calibration measured the inertia of actuator wrong.	1. Start calibration.
35	Stop time	-	-	Calibration meaasured the drifting wrong.	1. Start calibration.
36	Manual control	-	X	Error of communication of torque module.	1. Deactivation of input SW3 for manual control. 2. Check the parameter Manual control. If the manual control is not active the value of parameter must be OFF.
37	Position module	-	X	Error of communication of position module.	1. Check the wiring between module and control unit.
38	Torque module	-	X	Error of communication of torque module.	1. Check the wiring between module and control unit 2. Check the parameter of torque configuration. When the module torque is enabled then the parameter must be set to the switch-off min -100% or switch-off 100%.
39	Module LED	-	X	Error of communication of LED module	1. Check the wiring between module and control unit 2. Check the parameter LED module. When the module is used the value of parameter must be set to the X.

Code	Name	Warning <sup>1</sup>	Error <sup>1</sup>	Reason	Reparation
41	Wrong position	-	X	Position of an actuator is out of set stroke.	1. Using hand control set the position back into operation range. 2. Check the parameter Position O and Position C.
42	Power Supply/Relay module	-	X	Error of communication of Power Supply/Relay module.	1. Check the wiring between module and control unit 2. Check the parameter Power Supply/Relay module. When the module is used the value of parameter must be set to the X.
43	Parameters	-	X	Different or out of bounds parameters in EEPROM.	1. Only using EHL explorer app. Parameters which are reported as wrong write the new value from allowed range.
44	Rotation	-	X	Actuator is not rotating.	1. Check if the motor is rotating. If not remove the cause. 2. Check if the value Position absolute in window monitoring is changing. If the value is not changing during rotation then check the rotation of shaft with magnet of position sensor. 3. Check the parameter Rotation speed. Increase the value until it is ok.
45	Reset	X	-	Processor was incorrectly reset.	1. This error is counted in counter of errors and it is automatically resolved. If the error is generated often then contact the manufacturer.
46	Module LCD	-	X	Error of communication of LCD module.	1. Check the wiring between module and control unit 2. Check the parameter LCD module. When the module is used the value of parameter must be set to the X.
47	Module type Position	-	X	Unknown type of position module.	1. Use different type of module. This one is not supported by control unit. 2. Use the newer type of control unit.
48	Module type Torque	-	X	Unknown type of torque module.	
49	Module type LED	-	X	Unknown type of LED module.	
51	Module type LCD	-	X	Unknown type of LCD module.	
52	Module type Power Supply/Relay	-	X	Unknown type of PWR module.	
54	I2C	-	X	Error of communication of I2C bus.	1. Turn off and on the power line. 2. If the error is still active replace the control unit.
55	Power frequency	-	X	Indefinable Power frequency.	1. To test parameters your timing network and parameter power supply board the system. As far as power supply board non - support frequency timing network, replace her in suitable type. 2. To test connection power supply in source power supply board, not allowed give out toward his disconnecting i.e. bad contact.
56	Voltage +5V	X	-	Voltage less as 4,5 V	1. Change power supply board 2. Change control unit
57	Torque check	X	-	Parameter Torque check = unexecuted	1. Perform functional Torque check and setup parameter Torque check = Done
58	End position	-	-	During calibration regulator has been achieved end position.	1. Restart calibration regulator the best further from end positions.

<sup>1</sup> Codes of errors may vary in different version of firmware or factory settings.  
If the errors persist then contact the manufacturer.



■ LED ERR- error indication

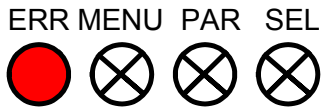

- AEL errors are indicated when LED ERR is blinking
- LED is flashed for a longer period, which indicates the beginning of the error.
  - The following number of blinks indicates:
  - Errors of the units 1...9
  - For the units 11...99 and after the short pause of the unit.

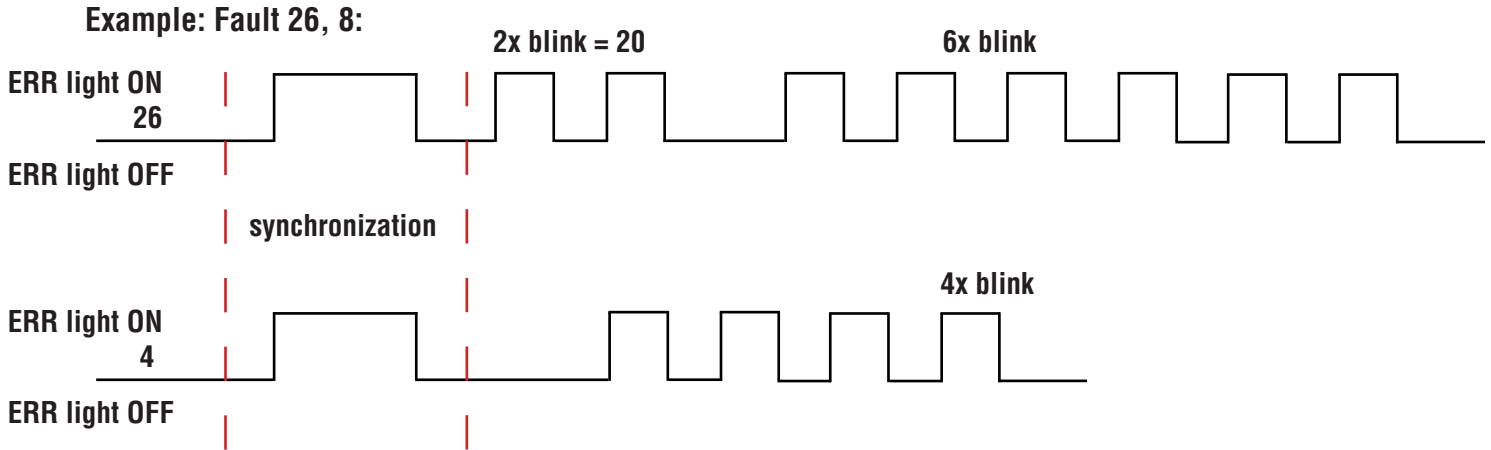

This would be code 26 item number 4 = Bus error / Consecutively connect particular modules. After each one check if the error occurred.

# Enclosures

## 8. Wiring Diagrams

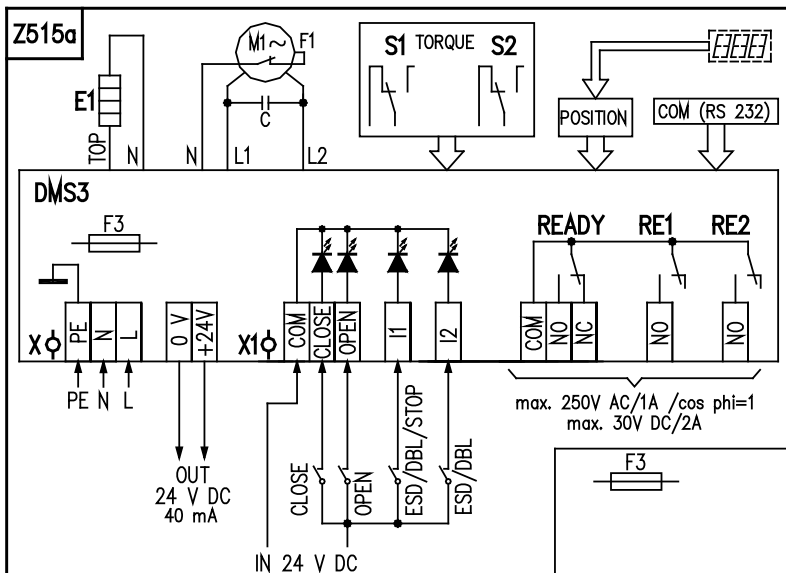
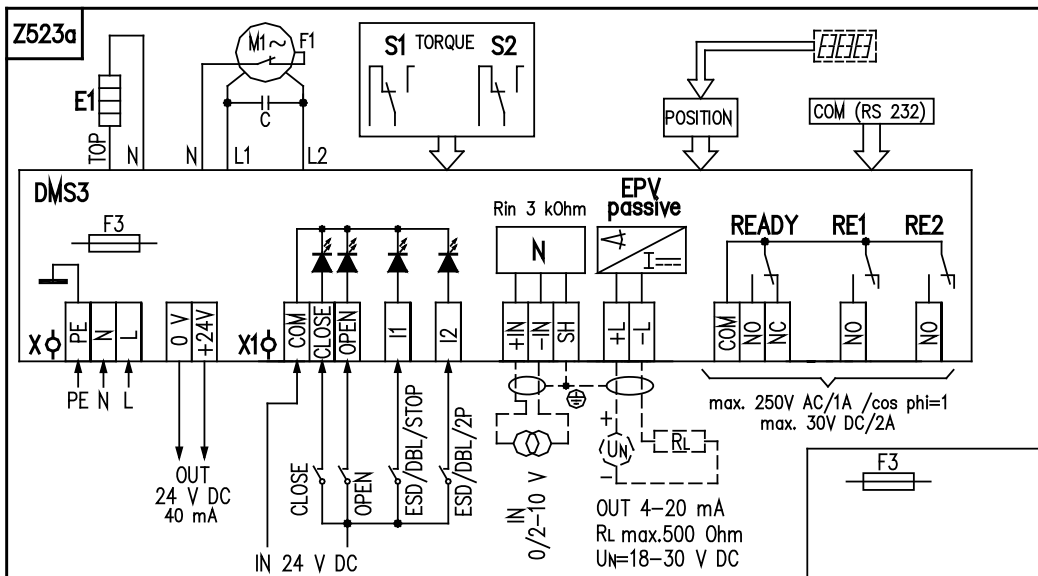
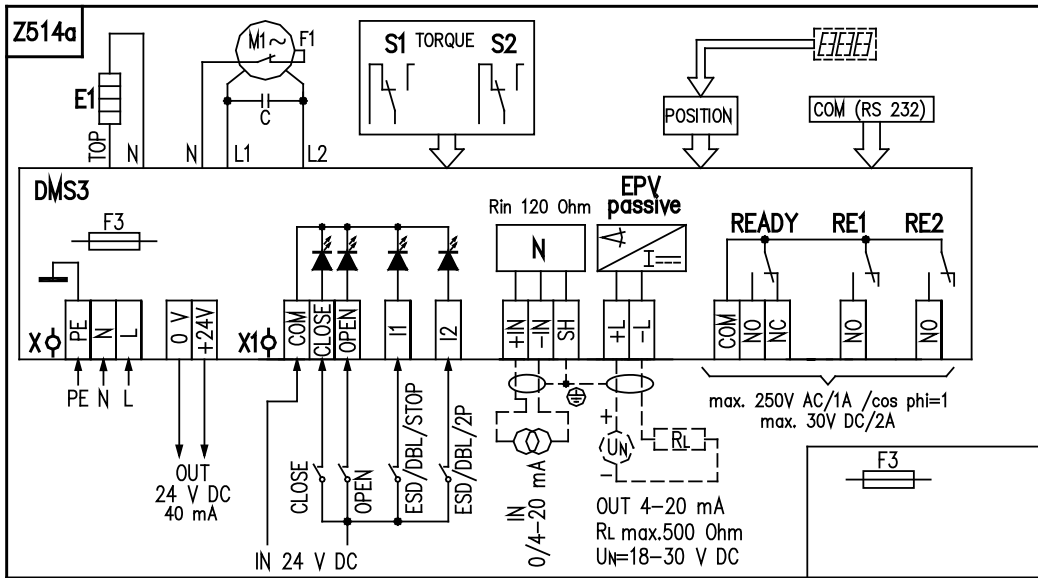

## Wiring Diagram Legend:

Z473a	wiring diagram of electric local control
Z500a	wiring diagram module with 3 additional relays
Z514a	wiring diagram of AEL for the ON/OFF control or for analogue input 0/4 - 20 mA and output signal 4 - 20 mA
Z515a	wiring diagram of AEL for the ON/OFF control
Z523A	wiring diagram of AEL for the ON/OFF control or for analogue input 0/2 - 10 V and output signal 4 - 20 mA
C	capacitor
COM (RS232)	possibility for connecting the control unit to and PC
EPV Passive	electronic position transmitter is passive with output current signal
E1	space heater
F1	motor's thermal protection
F3	fuse of voltage supply source
M	single phase electric motor
N	controller
POSITION	position scanning
$R_{in}$	input resistance
$R_l$	load resistance
$U_N$	voltage for EPV
RE1	free programmable relay
RE2	free programmable relay
READY	READY relay (free-programmable)
R1 to R5	additional relays
S1	thrust switch "open"
S2	thrust switch "closed"
DMS3	electronic module
X	voltage supply source terminal board with screw terminals
X1	terminal board with screw terminals on the control unit
X2	screw terminal box on the additional relays board

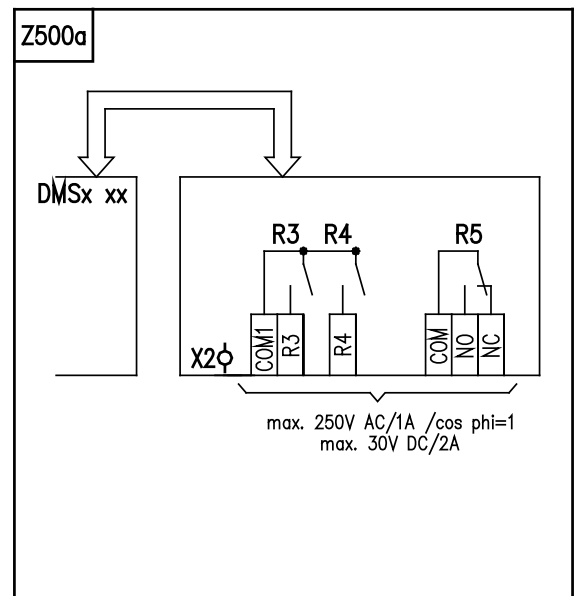
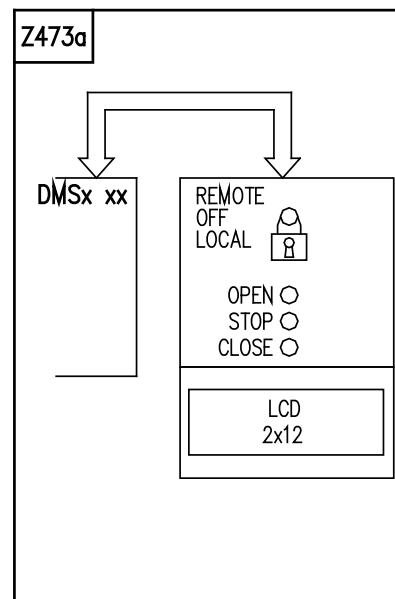

## Terminals:

PE, N, L	terminals (0,05 – 1,5 mm <sup>2</sup> ) of supply (24 V AC resp. 110/120 V AC, resp. 230/240 V AC, 50/60 Hz (according to the specification – voltage and frequency are stated on nameplate of EA)
0 V, +24 V	terminals (max. 0,05 – 1 mm <sup>2</sup> ) of output voltage 24 V DC (40 mA)
COM, CLOSE OPEN, I1, I2	terminals (0,05 – 1 mm <sup>2</sup> ) of control inputs 24 V DC
+IN, -IN, SH	terminals (0,05 – 1 mm <sup>2</sup> ) of unified input signal 0/4 – 20 mA
+L, -L, SH	terminals (0,05 – 1 mm <sup>2</sup> ) of output current signal (passive) 4-20 mA
COM, NO, NC	terminals (0,05 – 1,5 mm <sup>2</sup> ) of relay READY resp. relay R5
COM, NO	terminals (0,05 – 1,5 mm <sup>2</sup> ) of relay RE1, RE2
COM1, R3, R4	terminals (0,05-- 1,5 mm <sup>2</sup> ) relay R3, R4

\*Notes follow on page 26

■ **Note 1:**

On terminal N, L terminal power supply (X) feed supply voltage 230 V AC, or 24 V AC by you - specified type of construction EA. For supply voltage 24 V AC no need connect ground wire PE.

■ **Note 2:**

Program possibilities for **RE1, RE2, R3, R4, R5** relays: DISABLED, open position, close position, torque-open, torque – close, torque open or torque close, torque open or position open, torque close or position close, open, close, movement, movement flasher, to position, from position, warning, remote control, local control, control shut off.

Program possibilities for **READY** relay: errors, errors or warnings, errors or no remote, errors or warnings or no remote.

Program possibilities for output signal (from **EPV** passive): 4 to 20 mA, 20 to 4 mA.

Control programme options (regulating): 2P, 3P, 3P/2P switched over to I2

Program possibilities for **input control signal (N)**: 4 to 20 mA (2 to 10 V), 20 to 4 mA (10 to 2 V), 0 to 20 mA (0 to 10 V), 20 to 0 mA (10 to 0 V).

Program possibilities for **inputs I1**: DISABLED, ESD, DBL (local releasing, remote releasing - not valid for EA without local control), STOP.

Program possibilities for **inputs I2**: DISABLED, ESD, DBL (local releasing, remote releasing), STOP  
2P (when controller is switch on)(for control programme option 3P/2P I2)) allows control using the binary 24V DC inputs with I2 input activated.

Program possibilities of **FAILURE REACTION**: OPEN, CLOSE, STOP, SAFE POSITION.

The identical functions cannot be set on I1 & I2 inputs in addition to the disabled state (e.g., if the ESD function is set on I1 input, it is not possible to select the (ESD) function on I2 input at the same time.)



**Armstrong provides intelligent system solutions that improve utility performance, lower energy consumption, and reduce environmental emissions while providing an “enjoyable experience.”**



**Armstrong International**  
North America • Latin America • India • Europe / Middle East / Africa • China • Pacific Rim  
[www.armstronginternational.com](http://www.armstronginternational.com)