

DIMENSIONS & DATA CERTIFIED FOR:

Representative:

Order:

Customer:

Order:

Project:

Requirements:

By:

Date:

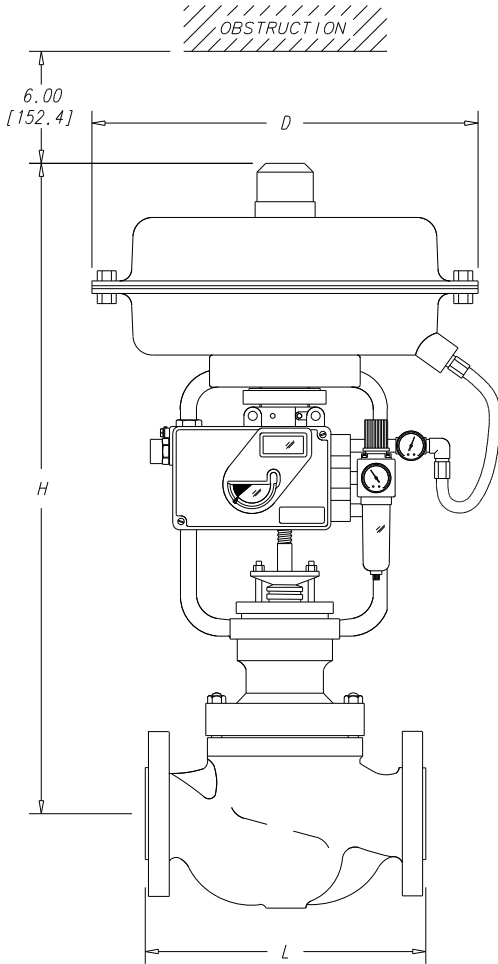

Dimensions & Weights							
SIZE NPT [DN]	ANSI FLG. CLASS	L	D	H	Cv	WEIGHT lbs [kgs]	
1/2 [15]	150#	7.00 [177.8]	11.42 [290.1]	18.50 [469.9]	5	34 [15.4]	
3/4 [20]		7.12 [181.0]			9		
1 [25]		7.25 [184.2]			13		
1-1/2 [40]		8.75 [222.2]			20.28 [515.1]	30	55 [24.9]
2 [50]		10.00 [254.0]				50	65 [29.5]
2-1/2 [65]		10.88 [276.4]				80	120 [54.4]
3 [80]		11.75 [298.4]	14.96 [380.0]	25.20 [640.1]	110	135 [61.2]	
4 [100]		13.88 [352.4]			200	176 [79.8]	
6 [150]		17.75 [450.9]			400	322.0 [146.0]	

Dimensions are in inches [mm]

LIST OF MATERIALS	
PART	MATERIAL
VALVE BODY	CARBON STEEL A216 GR. WCB
BONNET	CARBON STEEL A216 GR. WCB
VALVE / VALVE SEAT	STAINLESS STEEL AISI 431
VALVE STEM	STAINLESS STEEL 316
GLAND PACKING	V-TEFLON (OPTION 1) 366°F MAX. GRAFOIL (OPTION 2)
YOKE	S.G. IRON
ACTUATOR SPRING	CHROME VANADIUM SPRING STEEL
ACTUATOR DIAPHRAGM	NITRILE REINFORCED with NYLON FIBER

CONTROL VALVE TECHNICAL DATA		
PLUG DESIGN	CONTOURED TOP (UNBALANCED)	
FLOW CHARACTERISTICS	EQUAL PERCENTAGE	
LEAKAGE	ANSI CLASS IV	
RANGEABILITY	50:1	
TRAVEL	1/2" [15] - 1" [25]	0.7 [18]
	1-1/2" [40] - 2" [50]	1.1 [28]
	2-1/2" [65] - 4" [100]	1.5 [38]
	6" [150]	2.3 [58]
MAXIMUM TEMPERATURE	450°F [232°C]	
MAXIMUM PRESSURE	150 PSIG [10 bar]	

POSITIONER TECHNICAL DATA	
ANALOG	SETPOINT 4-20 mA
DISPLAY	MECHANICAL INDICATOR (STD.)
AIR SUPPLY	20-50 PSIG [1.4-3.5 bar]
PROTECTION CLASS	NEMA 4X
ELECTRICAL CLASSIFICATION FM / CSA	INTRINSIC SAFETY CLASS I, DIV. 1, GROUPS A, B, C, D
ELECTRICAL CONNECTION	1/2 NPT [15 DN]
PNEUMATIC CONNECTION	1/4 NPT [8 DN]
AMBIENT TEMPERATURE	-40° to +176°F [-40° to +80°C]

NOTES:

1. REDUCED TRIM Cv AVAILABLE.



Product ENGLISH
PYTHON 1100 SERIES CONTROL VALVE
 150# FLG'D CONTOURED TOP-GUIDED w/ANALOG POSITIONER

CD No.	Date
CD2095	10/23/07
Rev; B	By; Hooley

CD2095