

# DIMENSIONS & DATA CERTIFIED FOR:

Representative:

Order:

Customer:

Order:

Project:

Requirements:

By:

Date:

## INTEGRAL MOUNT

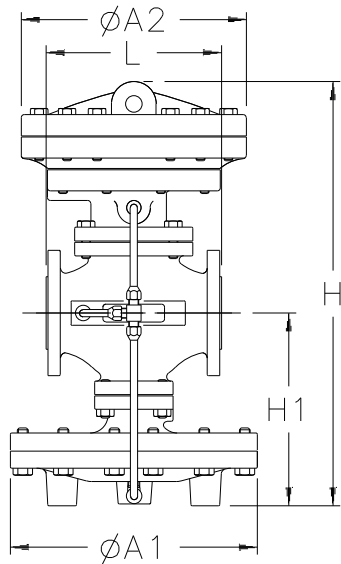

## REMOTE MOUNT

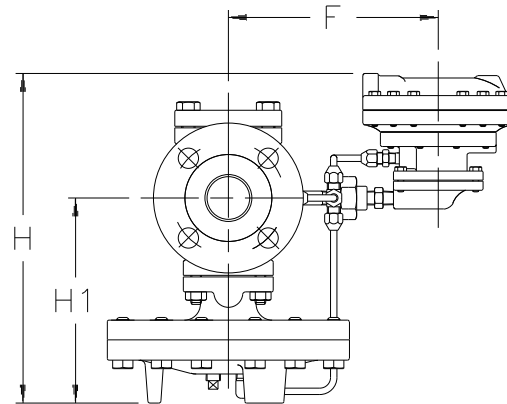

### Dimensions & Weights

SIZE	Flange Class	L	A1	F	H Integral	H Remote	H1	A2	Weight	Cv [Kv]
2" [50]	150	8-9/16" [217mm]	10-15/16" [278mm]	7-7/8" [200mm]	17-7/8" [454mm]	14" [356mm]	8-1/2" [216mm]	6-3/4" [171mm]	87 lbs. [39 kgs]	32 [28]
	300	9-1/8" [232mm]							90 lbs. [41 kgs]	
2-1/2" [65]	150	10-15/16" [278mm]	13-13/16" [351mm]	8-7/8" [225mm]	20-1/2" [521mm]	15-5/16" [389mm]	9-13/16" [249mm]	6-3/4" [171mm]	148 lbs. [67 kgs]	60 [52]
	300	11-1/2" [292mm]							156 lbs. [71 kgs]	
3" [80]	150	11-3/4" [298mm]	13-13/16" [351mm]	8-7/8" [225mm]	21-3/8" [543mm]	15-15/16" [405mm]	10-7/16" [265mm]	6-3/4" [171mm]	161 lbs. [73 kgs]	78 [67]
	300	12-7/16" [316mm]							172 lbs. [78 kgs]	
4" [100]	150	13-1/2" [343mm]	15-13/16" [402mm]	9-7/8" [251mm]	24-7/8" [632mm]	18-1/8" [460mm]	12-5/8" [321mm]	6-3/4" [171mm]	253 lbs. [115 kgs]	120 [104]
	300	14-1/8" [359mm]							270 lbs. [122 kgs]	



Armstrong Pressure/Temperature Group  
221 Armstrong Blvd.,  
Three Rivers, MI. 49093  
**Armstrong** (269) 279-3600 Fax(269) 273-8656  
Posted on Armstrong's homepage [www.armstrong-intl.com](http://www.armstrong-intl.com)

Product	CDY No.	Date
GP-2000K-2 FLANGED CONNECTIONS	1017	2/19/98
		Rev. A

Specifications				
Application	Inlet Pressure	Reduced Pressure	Maximum Temperature	Minimum Differential
Steam	CL. 150 FLG. 15-185 psig [1-12.6 bar]	15-200 psig [1-13.6 bar]	450 °F [232 °C]	7 psig [.48 bar]
	CL. 300 FLG. 15-300 psig [1-20.4 bar]			

List Of Materials	
Body	Ductile Iron ASTM A536
Main Valve/Seat	Stainless Steel AISI 420
Pilot Valve/Seat	Stainless Steel AISI 420
Diaphragm	Stainless Steel AISI 301

 Armstrong Pressure/Temperature Group 221 Armstrong Blvd., Three Rivers, MI. 49093 <b>Armstrong</b> (269) 279-3600 Fax(269) 273-8656 Posted on Armstrong's homepage <a href="http://www.armstrong-intl.com">www.armstrong-intl.com</a>		
Product	CDY No.	Date
GP-2000K-2 FLANGED CONNECTIONS	1017	2/18/98
		Rev. A