

DIMENSIONS & DATA CERTIFIED FOR:

Representative:

Order:

Customer:

Order:

Project:

Requirements:

By:

Date:

INTEGRAL MOUNT

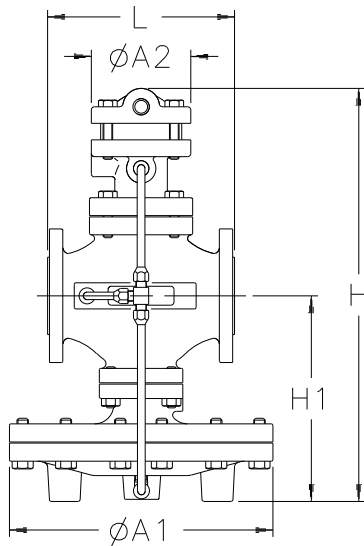

REMOTE MOUNT

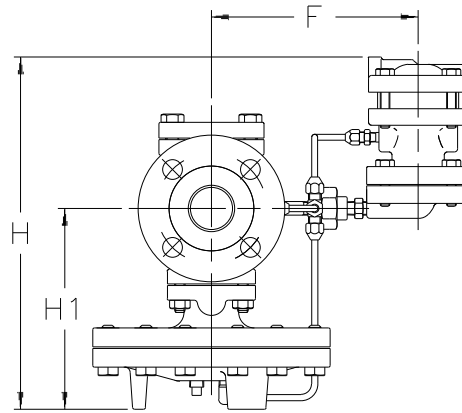

Dimensions & Weights

SIZE	Flange Class	L	A1	F	H Integral	H Remote	H1	A2	Weight	Cv [Kv]
2" [50]	150	8-5/8" [218mm]	10-15/16" [276mm]	7-11/16" [195mm]	16-1/2" [419mm]	12-5/8" [321mm]	8-1/2" [216mm]	3-1/4" [82mm]	81 lbs. [37 kgs]	32 [28]
	300	9-1/8" [232mm]							84 lbs. [38 kgs]	
2-1/2" [65]	150	10-15/16" [278mm]	13-13/16" [352mm]	8-5/16" [211mm]	18-5/8" [472mm]	14-3/4" [375mm]	9-13/16" [251mm]	3-1/4" [82mm]	142 lbs. [65 kgs]	60 [52]
	300	11-1/2" [292mm]							150 lbs. [68 kgs]	
3" [80]	150	11-3/4" [298mm]	13-13/16" [352mm]	8-3/4" [222mm]	19-1/2" [495mm]	15-3/4" [400mm]	10-7/16" [264mm]	3-1/4" [82mm]	155 lbs. [71 kgs]	78 [67]
	300	12-7/16" [316mm]							166 lbs. [75 kgs]	
4" [100]	150	13-1/2" [343mm]	15-13/16" [401mm]	9-7/16" [239mm]	22-3/4" [578mm]	19-1/4" [489mm]	12-5/8" [321mm]	3-1/4" [82mm]	247 lbs. [112 kgs]	120 [104]
	300	14-1/8" [359mm]							264 lbs. [119 kgs]	



Armstrong Pressure/Temperature Group
221 Armstrong Blvd.,
Three Rivers, MI. 49093
Armstrong (269) 279-3600 Fax(269) 273-8656
Posted on Armstrong's homepage www.armstrong-intl.com

Product	CDY No.	Date
GP-2000K-1 FLANGED CONNECTIONS	1015	2/18/98
		Rev. B

Specifications				
Application	Inlet Pressure	Reduced Pressure	Maximum Temperature	Minimum Differential
Steam	CL. 150 FLG. 15-185 psig [1-12.6 bar]	7-125 psig [0.48-8.6 bar]	450 °F [232 °C]	7 psig [.48 bar]
	CL. 300 FLG. 15-300 psig [1-20.4 bar]			

List Of Materials	
Body	Ductile Iron ASTM A536
Main Valve/Seat	Stainless Steel AISI 420
Pilot Valve/Seat	Stainless Steel AISI 420
Diaphragm	Stainless Steel AISI 301

 Armstrong Pressure/Temperature Group 221 Armstrong Blvd., Three Rivers, MI. 49093 Armstrong (269) 279-3600 Fax(269) 273-8656 Posted on Armstrong's homepage www.armstrong-intl.com		
Product	CDY No.	Date
GP-2000K-1 FLANGED CONNECTIONS	1015	2/18/98
		Rev. B