

How to Trap: Installation and Testing



Armstrong®



Armstrong® Bringing Energy Down to Earth

Say energy. Think environment. And vice versa.

Any company that is energy conscious is also environmentally conscious. Less energy consumed means less waste, fewer emissions and a healthier environment.

In short, bringing energy and environment together lowers the cost industry must pay for both. By helping companies manage energy, Armstrong products and services are also helping to protect the environment.

Armstrong has been sharing know-how since we invented the energy-efficient inverted bucket steam trap in 1911. In the years since, customers' savings have proven again and again that knowledge *not* shared is energy wasted.

Armstrong's developments and improvements in steam trap design and function have led to countless savings in energy, time and money. This section has grown out of our decades of sharing and expanding what we've learned. It deals with the operating principles of steam traps and outlines their specific applications to a wide variety of products and industries. You'll find it a useful complement to other Armstrong literature and the Armstrong Steam-A-ware™ software program for sizing and selecting steam traps, pressure reducing valves and water heaters, which can be requested through Armstrong's Web site, armstronginternational.com.

This section also includes Recommendation Charts that summarize our findings on which type of trap will give optimum performance in a given situation and why.

IMPORTANT: This section is intended to summarize general principles of installation and operation of steam traps, as outlined above. Actual installation and operation of steam trapping equipment should be performed only by experienced personnel. Selection or installation should always be accompanied by competent technical assistance or advice. This data should never be used as a substitute for such technical advice or assistance. We encourage you to contact Armstrong or its local representative for further details.

Instructions for Using the Recommendation Charts



A quick reference Recommendation Chart appears throughout the “HOW TO TRAP” brochures (857-EN - 868-EN).

A feature code system (ranging from A to Q) supplies you with “at-a-glance” information.

The chart covers the type of steam traps and the major advantages that Armstrong feels are superior for each particular application.

For example, assume you are looking for information concerning the proper trap to use on a gravity drained jacketed kettle. You would:

1. Turn to the “How to Trap Jacketed Kettles” brochure, 864-EN, and look in the lower right-hand corner of page 10. The Recommendation Chart located there is reprinted below for your convenience. (Each section has a Recommendation Chart.)
2. Find “Jacketed Kettles, Gravity Drain” in the first column under “Equipment Being Trapped” and read to the right for Armstrong’s “1st Choice and Feature Code.” In this case, the first choice is an IBLV and the feature code letters B, C, E, K, N are listed.

3. Now refer to Chart 3-2 below, titled “How Various Types of Steam Traps Meet Specific Operating Requirements” and read down the extreme left-hand column to each of the letters B, C, E, K, N. The letter “B,” for example, refers to the trap’s ability to provide energy-conserving operation.
4. Follow the line for “B” to the right until you reach the column that corresponds to our first choice, in this case the inverted bucket. Based on tests and actual operating conditions, the energy-conserving performance of the inverted bucket steam trap has been rated “Excellent.” Follow this same procedure for the remaining letters.

Abbreviations

- IB Inverted Bucket Trap
- IBLV Inverted Bucket Large Vent
- BM Bimetallic Trap
- F&T Float and Thermostatic Trap
- CD Controlled Disc Trap
- DC Automatic Differential Condensate Controller
- CV Check Valve
- T Thermic Bucket
- PRV Pressure Reducing Valve

Chart 3-1. Recommendation Chart (See chart below for “Feature Code” References.)		
Equipment Being Trapped	1st Choice and Feature Code	Alternate Choice
Jacketed Kettles Gravity Drain	IBLV B, C, E, K, N	F&T or Thermostatic
Jacketed Kettles Syphon Drain	DC B, C, E, G, H, K, N, P	IBLV

Chart 3-2. How Various Types of Steam Traps Meet Specific Operating Requirements								
Feature Code	Characteristic	IB	BM	F&T	Disc	Thermostatic Wafer	DC	Orifice
A	Method of Operation	(1) Intermittent	(2) Intermittent	Continuous	Intermittent	(2) Intermittent	Continuous	Continuous
B	Energy Conservation (Time in Service)	Excellent	Excellent	Good	Poor	Fair	(3) Excellent	Poor
C	Resistance to Wear	Excellent	Excellent	Good	Poor	Fair	Excellent	Poor
D	Corrosion Resistance	Excellent	Excellent	Good	Excellent	Good	Excellent	Good
E	Resistance to Hydraulic Shock	Excellent	Excellent	Poor	Excellent	(4) Poor	Excellent	Good
F	Vents Air and CO ₂ at Steam Temperature	Yes	No	No	No	No	Yes	Poor
G	Ability to Vent Air at Very Low Pressure (1/4 psig)	Poor	(5) NR	Excellent	(5) NR	Good	Excellent	Poor
H	Ability to Handle Start-Up Air Loads	Fair	Excellent	Excellent	Poor	Excellent	Excellent	Poor
I	Operation Against Back Pressure	Excellent	Excellent	Excellent	Poor	Excellent	Excellent	Poor
J	Resistance to Damage From Freezing	(6) Good	Good	Poor	Good	Good	Good	Excellent
K	Ability to Purge System	Excellent	Good	Fair	Excellent	Good	Excellent	Poor
L	Performance on Very Light Loads	Excellent	Excellent	Excellent	Poor	Excellent	Excellent	Poor
M	Responsiveness to Slugs of Condensate	Immediate	Delayed	Immediate	Delayed	Delayed	Immediate	Poor
N	Ability to Handle Dirt	Excellent	Fair	Poor	Poor	Fair	Excellent	Poor
O	Comparative Physical Size (7)	Large	Small	Large	Small	Small	Large	Small
P	Ability to Handle “Flash Steam”	Fair	Poor	Poor	Poor	Poor	Excellent	Poor
Q	Mechanical Failure (Open or Closed)	Open	Open	Closed	(8) Open	(9)	Open	NA

- (1) Drainage of condensate is continuous. Discharge is intermittent.
- (2) Can be continuous on low load.
- (3) Excellent when “secondary steam” is utilized.
- (4) Bimetallic and wafer traps – good.
- (5) Not recommended for low pressure operations.

- (6) Cast iron traps not recommended.
- (7) In welded stainless steel construction – medium.
- (8) Can fail closed due to dirt.
- (9) Can fail either open or closed, depending upon the design of the bellows.

Designs, materials, weights and performance ratings are approximate and subject to change without notice. Visit armstronginternational.com for up-to-date information.

What They Are...How to Use Them

The heat quantities and temperature/pressure relationships referred to in this section are taken from the Properties of Saturated Steam table.

Definitions of Terms Used

Saturated Steam is pure steam at the temperature that corresponds to the boiling temperature of water at the existing pressure.

Absolute and Gauge Pressures

Absolute pressure is pressure in pounds per square inch (psia) above a perfect vacuum. Gauge pressure is pressure in pounds per square inch above atmospheric pressure, which is 14.7 pounds per square inch absolute. Gauge pressure (psig) plus 14.7 equals absolute pressure. Or, absolute pressure minus 14.7 equals gauge pressure.

Pressure/Temperature Relationship

(Columns 1, 2 and 3). For every pressure of pure steam there is a corresponding temperature. Example: The temperature of 250 psig pure steam is always 406°F.

Heat of Saturated Liquid (Column 4).

This is the amount of heat required to raise the temperature of a pound of water from 32°F to the boiling point at the pressure and temperature shown. It is expressed in British thermal units (Btu).

Latent Heat or Heat of Vaporization

(Column 5). The amount of heat (expressed in Btu) required to change a pound of boiling water to a pound of steam. This same amount of heat is released when a pound of steam is condensed back into a pound of water. This heat quantity is different for every pressure/temperature combination, as shown in the steam table.

Total Heat of Steam (Column 6). The sum of the Heat of the Liquid (Column 4) and Latent Heat (Column 5) in Btu. It is the total heat in steam above 32°F.

Specific Volume of Liquid (Column 7).

The volume per unit of mass in cubic feet per pound.

Specific Volume of Steam (Column 8).

The volume per unit of mass in cubic feet per pound.

How the Table Is Used

In addition to determining pressure/temperature relationships, you can compute the amount of steam that will be condensed by any heating unit of known Btu output. Conversely, the

table can be used to determine Btu output if steam condensing rate is known. In the application portion of this section, there are several references to the use of the steam table.

Table 4-1. Properties of Saturated Steam
(Abstracted from Keenan and Keyes, THERMODYNAMIC PROPERTIES OF STEAM, by permission of John Wiley & Sons, Inc.)

	Col. 1 Gauge Pressure	Col. 2 Absolute Pressure (psia)	Col. 3 Steam Temp. (°F)	Col. 4 Heat of Sat. Liquid (Btu/lb)	Col. 5 Latent Heat (Btu/ lb)	Col. 6 Total Heat of Steam (Btu/lb)	Col. 7 Specific Volume of Sat. Liquid (cu ft/lb)	Col. 8 Specific Volume of Sat. Steam (cu ft/lb)
Inches of Vacuum	29.743	0.08854	32.00	0.00	1075.8	1075.8	0.016022	3306.00
	29.515	0.2	53.14	21.21	1063.8	1085.0	0.016027	1526.00
	27.886	1.0	101.74	69.70	1036.3	1106.0	0.016136	333.60
	19.742	5.0	162.24	130.13	1001.0	1131.0	0.016407	73.52
	9.562	10.0	193.21	161.17	982.1	1143.3	0.016590	38.42
	7.536	11.0	197.75	165.73	979.3	1145.0	0.016620	35.14
	5.490	12.0	201.96	169.96	976.6	1146.6	0.016647	32.40
	3.454	13.0	205.88	173.91	974.2	1148.1	0.016674	30.06
	1.418	14.0	209.56	177.61	971.9	1149.5	0.016699	28.04
	PSIG	0.0	14.696	212.00	180.07	970.3	1150.4	0.016715
1.3		16.0	216.32	184.42	967.6	1152.0	0.016746	24.75
2.3		17.0	219.44	187.56	965.5	1153.1	0.016768	23.39
5.3		20.0	227.96	196.16	960.1	1156.3	0.016830	20.09
10.3		25.0	240.07	208.42	952.1	1160.6	0.016922	16.30
15.3		30.0	250.33	218.82	945.3	1164.1	0.017004	13.75
20.3		35.0	259.28	227.91	939.2	1167.1	0.017078	11.90
25.3		40.0	267.25	236.03	933.7	1169.7	0.017146	10.50
30.3		45.0	274.44	243.36	928.6	1172.0	0.017209	9.40
40.3		55.0	287.07	256.30	919.6	1175.9	0.017325	7.79
50.3		65.0	297.97	267.50	911.6	1179.1	0.017429	6.66
60.3		75.0	307.60	277.43	904.5	1181.9	0.017524	5.82
70.3		85.0	316.25	286.39	897.8	1184.2	0.017613	5.17
80.3		95.0	324.12	294.56	891.7	1186.2	0.017696	4.65
90.3		105.0	331.36	302.10	886.0	1188.1	0.017775	4.23
100.0		114.7	337.90	308.80	880.0	1188.8	0.017850	3.88
110.3		125.0	344.33	315.68	875.4	1191.1	0.017922	3.59
120.3		135.0	350.21	321.85	870.6	1192.4	0.017991	3.33
125.3		140.0	353.02	324.82	868.2	1193.0	0.018024	3.22
130.3		145.0	355.76	327.70	865.8	1193.5	0.018057	3.11
140.3		155.0	360.50	333.24	861.3	1194.6	0.018121	2.92
150.3		165.0	365.99	338.53	857.1	1195.6	0.018183	2.75
160.3		175.0	370.75	343.57	852.8	1196.5	0.018244	2.60
180.3		195.0	379.67	353.10	844.9	1198.0	0.018360	2.34
200.3		215.0	387.89	361.91	837.4	1199.3	0.018470	2.13
225.3		240.0	397.37	372.12	828.5	1200.6	0.018602	1.92
250.3		265.0	406.11	381.60	820.1	1201.7	0.018728	1.74
		300.0	417.33	393.84	809.0	1202.8	0.018896	1.54
	400.0	444.59	424.00	780.5	1204.5	0.019340	1.16	
	450.0	456.28	437.20	767.4	1204.6	0.019547	1.03	
	500.0	467.01	449.40	755.0	1204.4	0.019748	0.93	
	600.0	486.21	471.60	731.6	1203.2	0.02013	0.77	
	900.0	531.98	526.60	668.8	1195.4	0.02123	0.50	
	1200.0	567.22	571.70	611.7	1183.4	0.02232	0.36	
	1500.0	596.23	611.60	556.3	1167.9	0.02346	0.28	
	1700.0	613.15	636.30	519.6	1155.9	0.02428	0.24	
	2000.0	635.82	671.70	463.4	1135.1	0.02565	0.19	
	2500.0	668.13	730.60	360.5	1091.1	0.02860	0.13	
	2700.0	679.55	756.20	312.1	1068.3	0.03027	0.11	
	3206.2	705.40	902.70	902.70	0.0	902.7	0.05053	0.05

Flash Steam (Secondary)

What is flash steam? When hot condensate or boiler water, under pressure, is released to a lower pressure, part of it is re-evaporated, becoming what is known as flash steam.

Why is it important? This flash steam is important because it contains heat units that can be used for economical plant operation—and which are otherwise wasted.

How is it formed? When water is heated at atmospheric pressure, its temperature rises until it reaches 212°F, the highest temperature at which water can exist at this pressure. Additional heat does not raise the temperature, but converts the water to steam.

The heat absorbed by the water in raising its temperature to boiling point is called “sensible heat” or heat of saturated liquid. The heat required to convert water at boiling point to steam at the same temperature is called “latent heat.” The unit of heat in common use is the Btu, which is the amount of heat required to raise the temperature of one pound of water 1°F at atmospheric pressure.

If water is heated under pressure, however, the boiling point is higher than 212°F, so the sensible heat required is greater. The higher the pressure, the higher the boiling temperature and the higher the heat content. If pressure is reduced, a certain amount of sensible heat is released. This excess heat will be absorbed in the form of latent heat, causing part of the water to “flash” into steam.

Condensate at steam temperature and under 100 psig pressure has a heat content of 308.8 Btu per pound. (See Column 4 in Steam Table.) If this condensate is discharged to atmospheric pressure (0 psig), its heat content instantly drops to 180 Btu per pound. The surplus of 128.8 Btu re-evaporates or flashes a portion of the condensate. The percentage that will flash to steam can be computed using the formula:

$$\% \text{ flash steam} = \frac{SH - SL}{H} \times 100$$

- SH = Sensible heat in the condensate at the higher pressure before discharge.
- SL = Sensible heat in the condensate at the lower pressure to which discharge takes place.
- H = Latent heat in the steam at the lower pressure to which the condensate has been discharged.

$$\% \text{ flash steam} = \frac{308.8 - 180}{970.3} \times 100 = 13.3\%$$

Chart 5-3 shows the amount of secondary steam that will be formed when discharging condensate to different pressures. **Other useful tables will be found in brochure 873-EN (Useful Engineering Tables).**

Chart 5-3.
Percentage of flash steam formed when discharging condensate to reduced pressure.

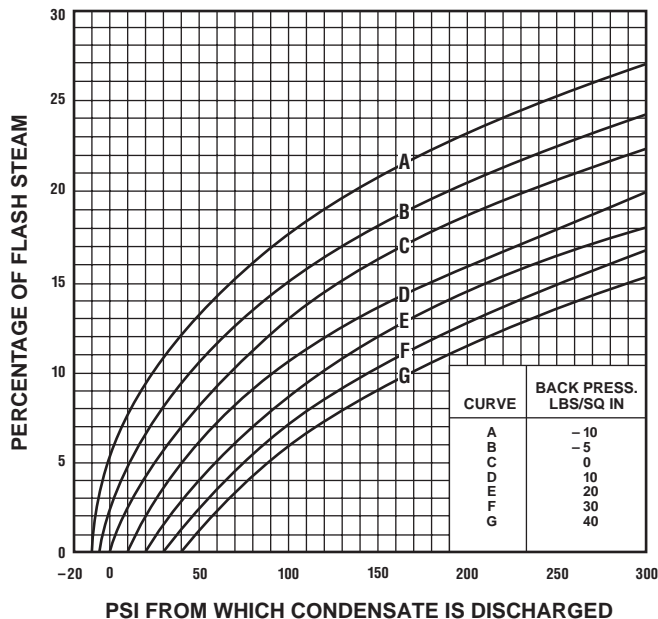
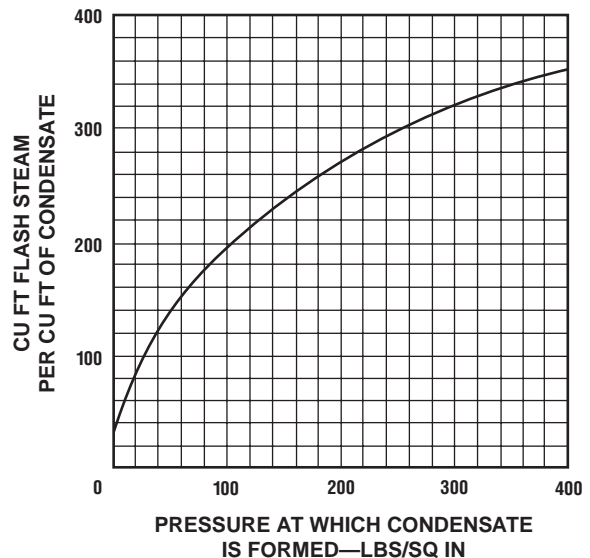

Chart 5-4.
Volume of flash steam formed when one cubic foot of condensate is discharged to atmospheric pressure.



Steam is an invisible gas generated by adding heat energy to water in a boiler. Enough energy must be added to raise the temperature of the water to the boiling point. Then additional energy—without any further increase in temperature—changes the water to steam.

Steam is a very efficient and easily controlled heat transfer medium. It is most often used for transporting energy from a central location (the boiler) to any number of locations in the plant where it is used to heat air, water or process applications.

As noted, additional Btu are required to make boiling water change to steam. These Btu are not lost but stored in the steam ready to be released to heat air, cook tomatoes, press pants or dry a roll of paper.

The heat required to change boiling water into steam is called the heat of vaporization or latent heat. The quantity is different for every pressure/temperature combination, as shown in the steam tables.

Steam at Work...

How the Heat of Steam Is Utilized

Heat flows from a higher temperature level to a lower temperature level in a process known as heat transfer. Starting in the combustion chamber of the boiler, heat flows through the boiler tubes to the water. When the higher pressure in the boiler pushes steam out, it heats the pipes of the distribution system. Heat flows from the steam through the walls of the pipes into the cooler surrounding air. This heat transfer changes some of the steam back into water. That's why distribution lines are usually insulated to minimize this wasteful and undesirable heat transfer.

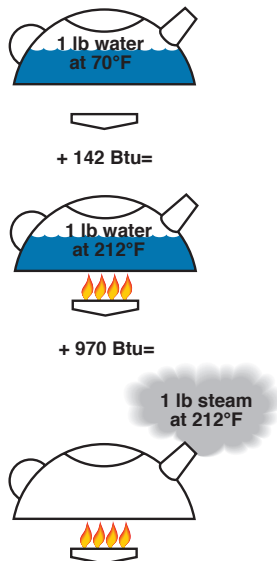

Figure 6-1. These drawings show how much heat is required to generate one pound of steam at atmospheric pressure. Note that it takes 1 Btu for every 1°F increase in temperature up to the boiling point, but that it takes more Btu to change water at 212°F to steam at 212°F.

When steam reaches the heat exchangers in the system, the story is different. Here the transfer of heat from the steam is desirable. Heat flows to the air in an air heater, to the water in a water heater or to food in a cooking kettle. Nothing should interfere with this heat transfer.

Condensate Drainage... Why It's Necessary

Condensate is the by-product of heat transfer in a steam system. It forms in the distribution system due to unavoidable radiation. It also forms in heating and process equipment as a result of desirable heat transfer from the steam to the substance heated. Once the steam has condensed and given up its valuable latent heat, the hot condensate must be removed immediately. Although the available heat in a pound of condensate is negligible as compared to a pound of steam, condensate is still valuable hot water and should be returned to the boiler.

Definitions

- **The Btu.** A Btu—British thermal unit—is the amount of heat energy required to raise the temperature of one pound of cold water by 1°F. Or, a Btu is the amount of heat energy given off by one pound of water in cooling, say, from 70°F to 69°F.
- **Temperature.** The degree of hotness with no implication of the amount of heat energy available.
- **Heat.** A measure of energy available with no implication of temperature. To illustrate, the one Btu that raises one pound of water from 39°F to 40°F could come from the surrounding air at a temperature of 70°F or from a flame at a temperature of 1,000°F.

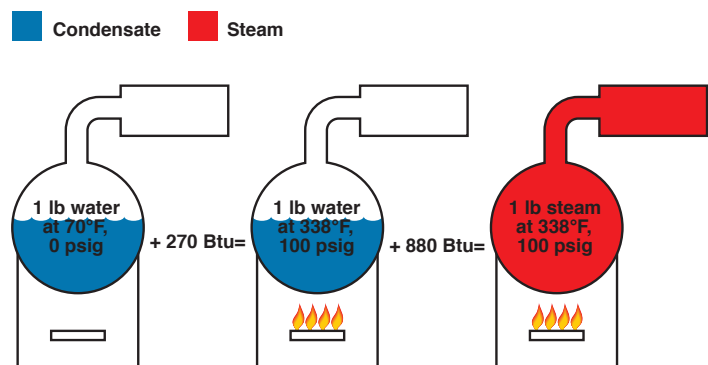

Figure 6-2. These drawings show how much heat is required to generate one pound of steam at 100 pounds per square inch pressure. Note the extra heat and higher temperature required to make water boil at 100 pounds pressure than at atmospheric pressure. Note, too, the lesser amount of heat required to change water to steam at the higher temperature.

The need to drain the distribution system. Condensate lying in the bottom of steam lines can be the cause of one kind of water hammer. Steam traveling at up to 100 miles per hour makes “waves” as it passes over this condensate (Fig. 7-4). If enough condensate forms, high-speed steam pushes it along, creating a dangerous slug that grows larger and larger as it picks up liquid in front of it. Anything that changes the direction—pipe fittings, regulating valves, tees, elbows, blind flanges—can be destroyed. In addition to damage from this “battering ram,” high-velocity water may erode fittings by chipping away at metal surfaces.

The need to drain the heat transfer unit. When steam comes in contact with condensate cooled below the temperature of steam, it can produce another kind of water hammer known as *thermal shock*. Steam occupies a much greater volume than condensate, and when it collapses suddenly, it can send shock waves throughout the system. This form of water hammer can damage equipment, and it signals that condensate is not being drained from the system. Obviously, condensate in the heat transfer unit takes up space and reduces the physical size and capacity of the equipment. Removing it quickly keeps the unit full of steam (Fig. 7-5). As steam condenses, it forms a film of water on the inside of the heat exchanger. Non-condensable gases do not change into liquid and flow away by gravity. Instead, they accumulate as a thin film on the surface of the heat exchanger—along with dirt and scale. All are potential barriers to heat transfer (Fig. 7-3).

The need to remove air and CO₂. Air is always present during equipment start-up and in the boiler feedwater. Feedwater may also contain dissolved carbonates, which release carbon dioxide gas. The steam velocity pushes the gases to the walls of the heat exchangers, where they may block heat transfer. This compounds the condensate drainage problem, because these gases must be removed along with the condensate.

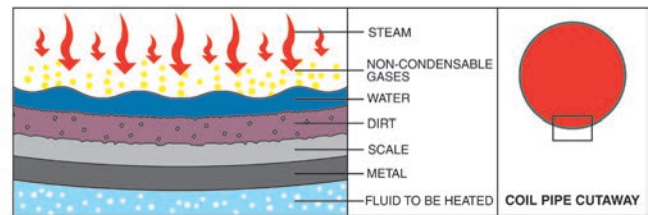

Figure 7-3. Potential barriers to heat transfer: steam heat and temperature must penetrate these potential barriers to do their work.

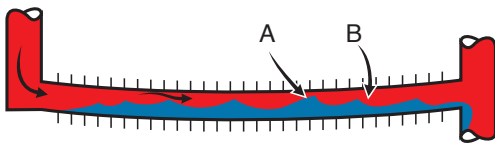

Figure 7-4. Condensate allowed to collect in pipes or tubes is blown into waves by steam passing over it until it blocks steam flow at point A. Condensate in area B causes a pressure differential that allows steam pressure to push the slug of condensate along like a battering ram.

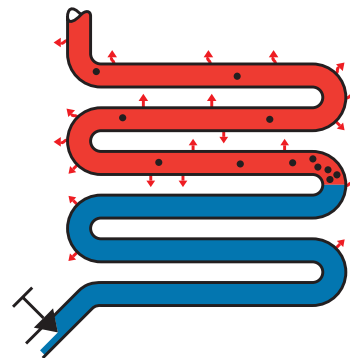

Figure 7-5. Coil half full of condensate can't work at full capacity.

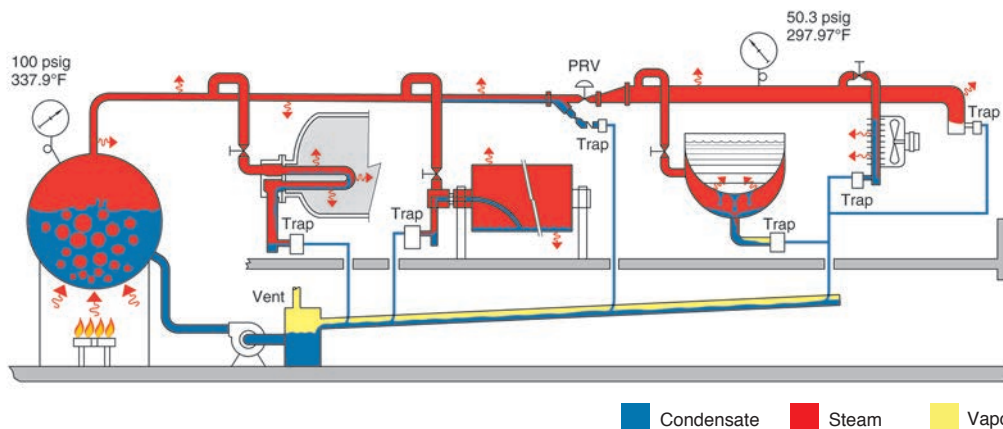

Figure 7-6. Note that heat radiation from the distribution system causes condensate to form and, therefore, requires steam traps at natural low points or ahead of control valves. In the heat exchangers, traps perform the vital function of removing the condensate before it becomes a barrier to heat transfer. Hot condensate is returned through the traps to the boiler for reuse.

Effect of Air on Steam Temperature

When air and other gases enter the steam system, they consume part of the volume that steam would otherwise occupy. The temperature of the air/steam mixture falls below that of pure steam. Figure 8-7 explains the effect of air in steam lines. Table 8-2 and Chart 8-5 show the various temperature reductions caused by air at various percentages and pressures.

Effect of Air on Heat Transfer

The normal flow of steam toward the heat exchanger surface carries air and other gases with it. Since they do not condense and drain by gravity, these non-condensable gases set up a barrier between the steam and the heat exchanger surface. The excellent insulating properties of air reduce heat transfer. In fact, under certain conditions as little as 1/2 of 1% by volume of air in steam can reduce heat transfer efficiency by 50% (Fig. 9-8).

Table 8-2. Temperature Reduction Caused by Air

Pressure (psig)	Temp. of Steam, No Air Present (°F)	Temp. of Steam Mixed With Various Percentages of Air (by Volume) (°F)		
		10%	20%	30%
10.3	240.1	234.3	228.0	220.9
25.3	267.3	261.0	254.1	246.4
50.3	298.0	291.0	283.5	275.1
75.3	320.3	312.9	304.8	295.9
100.3	338.1	330.3	321.8	312.4

Figure 8-7. Chamber containing air and steam delivers only the heat of the partial pressure of the steam, not the total pressure.

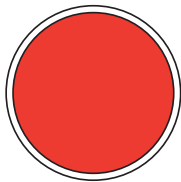

Steam chamber 100% steam
Total pressure 100 psia
Steam pressure 100 psia
Steam temperature 327.8°F

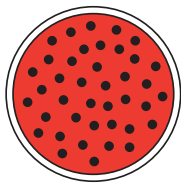

Steam chamber 90% steam and 10% air
Total pressure 100 psia
Steam pressure 90 psia
Steam temperature 320.3°F

When non-condensable gases (primarily air) continue to accumulate and are not removed, they may gradually fill the heat exchanger with gases and stop the flow of steam altogether. The unit is then "air bound."

Corrosion

Two primary causes of scale and corrosion are carbon dioxide (CO₂) and oxygen. CO₂ enters the system as carbonates dissolved in feedwater and, when mixed with cooled condensate, creates carbonic acid. Extremely corrosive, carbonic acid can eat through piping and heat exchangers (Fig. 9-9). Oxygen enters the system as gas dissolved in the cold feedwater. It aggravates the action of carbonic acid, speeding corrosion and pitting iron and steel surfaces (Fig. 9-10).

Eliminating the Undesirables

To summarize, traps must drain condensate because it can reduce heat transfer and cause water hammer. Traps should evacuate air and other non-condensable gases because they can reduce heat transfer by reducing steam temperature and insulating the system. They can also foster destructive corrosion. It's essential to remove condensate, air and CO₂ as quickly and completely as possible. A *steam trap*, which is simply an automatic valve that opens for condensate, air and CO₂ and closes for steam, does this job. For economic reasons, the steam trap should do its work for long periods with minimum attention.

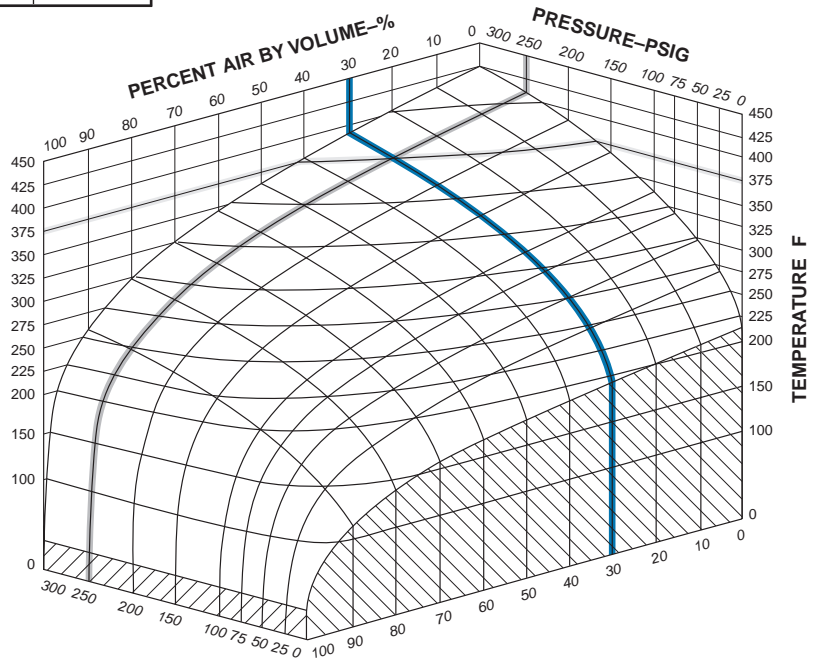

Chart 8-5. Air Steam Mixture

Temperature reduction caused by various percentages of air at differing pressures. This chart determines the percentage of air with known pressure and temperature by determining the point of intersection between pressure, temperature and percentage of air by volume. As an example, assume system pressure of 250 psig with a temperature at the heat exchanger of 375°F. From the chart, it is determined that there is 30% air by volume in the steam.

What the Steam Trap Must Do

The job of the steam trap is to get condensate, air and CO₂ out of the system as quickly as they accumulate. In addition, for overall efficiency and economy, the trap must also provide:

- 1. Minimal steam loss.** Table 9-3 shows how costly unattended steam leaks can be.
- 2. Long life and dependable service.** Rapid wear of parts quickly brings a trap to the point of unavailability. An efficient trap saves money by minimizing trap testing, repair, cleaning, downtime and associated losses.
- 3. Corrosion resistance.** Working trap parts should be corrosion-resistant in order to combat the damaging effects of acidic or oxygen-laden condensate.
- 4. Air venting.** Air can be present in steam at any time and especially on start-up. Air must be vented for efficient heat transfer and to prevent system binding.
- 5. CO₂ venting.** Venting CO₂ at steam temperature will prevent the formation of carbonic acid. Therefore, the steam trap must function at or near steam temperature since CO₂ dissolves in condensate that has cooled below steam temperature.
- 6. Operation against back pressure.** Pressurized return lines can occur both by design and unintentionally. A steam trap should be able to operate against the actual back pressure in its return system.

Figure 9-8. Steam condensing in a heat transfer unit moves air to the heat transfer surface, where it collects or “plates out” to form effective insulation.

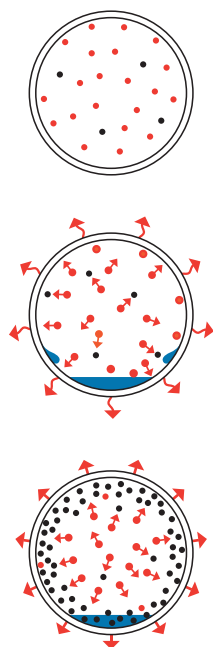

■ Condensate ■ Steam

- 7. Freedom from dirt problems.** Dirt is an ever-present concern since traps are located at low points in the steam system. Condensate picks up dirt and scale in the piping, and solids may carry over from the boiler. Even particles passing through strainer screens are erosive and, therefore, the steam trap must be able to operate in the presence of dirt.

A trap delivering anything less than all these desirable operating/design features will reduce the efficiency of the system and increase costs. When a trap delivers all these features the system can achieve:

1. Fast heat-up of heat transfer equipment
2. Maximum equipment temperature for enhanced steam heat transfer
3. Maximum equipment capacity
4. Maximum fuel economy
5. Reduced labor per unit of output
6. Minimum maintenance and a long trouble-free service life

Sometimes an application may demand a trap without these design features, but in the vast majority of applications the trap which meets all the requirements will deliver the best results.

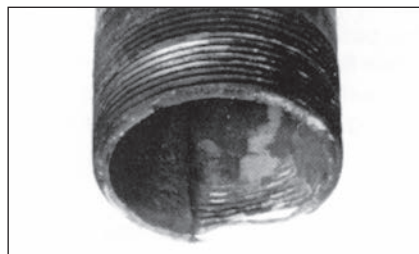

Figure 9-9. CO₂ gas combines with condensate allowed to cool below steam temperature to form carbonic acid, which corrodes pipes and heat transfer units. Note groove eaten away in the pipe illustrated.

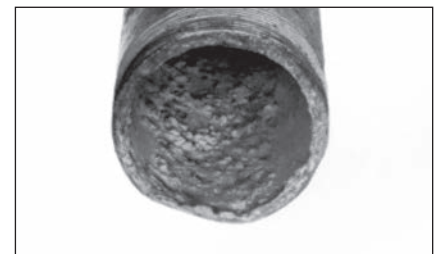

Figure 9-10. Oxygen in the system speeds corrosion (oxidation) of pipes, causing pitting such as shown here.

Figs. 9-9 and 9-10 courtesy of Dearborn Chemical Company.

Table 9-3. Cost of Various Sized Steam Leaks at 100 psi
(Assuming steam costs \$10.00/1,000 lbs)

Size of Orifice		Lbs Steam Wasted Per Month	Total Cost Per Month (USD)	Total Cost Per Year (USD)
1/2"	12, 7 mm	553,000	\$5,530.00	\$66,360.00
7/16"	11, 2 mm	423,500	4,235.00	50,820.00
3/8"	9, 5 mm	311,000	3,110.00	37,320.00
5/16"	7, 9 mm	216,000	2,160.00	25,920.00
1/4"	6, 4 mm	138,000	1,380.00	16,560.00
3/16"	4, 8 mm	78,000	780.00	9,360.00
1/8"	3, 2 mm	34,500	345.00	4,140.00

The steam loss values assume typical condensate load for drip trap applications. Armstrong methodology for steam trap management and condensate return is sanctioned by the Clean Development Mechanism of the United Nations Framework Convention on Climate Change.



Armstrong® Installation and Testing of Armstrong Steam Traps

Before Installing

Run pipe to trap. Before installing the trap, clean the line by blowing down with steam or compressed air. (Clean any strainer screens after this blowdown.)

Trap Location ABCs

Accessible for inspection and repair.

Below drip point whenever possible.

Close to drip point.

Trap Hookups. For typical hookups, see Figs. 10-60 (below) through 13-71, pages 10 through 13.

Shutoff Valves ahead of traps are needed when traps drain steam mains, large water heaters, etc., where system cannot be shut down for trap maintenance. They are not needed for small steam-heated machines—a laundry press, for example. Shutoff valve in steam supply to machine is usually sufficient.

Shutoff Valves in trap discharge line are needed when trap has a by-pass. It is a good idea when there is high pressure in discharge header. See also Check Valves.

By-passes (Figs. 11-64 and 11-65) are discouraged, for if left open, they will defeat the function of the trap. If continuous service is absolutely required, use two traps in parallel, one as a primary, one as a standby.

Unions. If only one is used, it should be on discharge side of trap. With two unions, avoid horizontal or vertical in-line installations. The best practice is to install at right angles as in Figs. 10-60 and 11-64, or parallel as in Fig. 11-65.

Standard Connections. Servicing is simplified by keeping lengths of inlet and outlet nipples identical for traps of a given size and type. A spare trap with identical fittings and half unions can be kept in storeroom. In the event a trap needs repair, it is a simple matter to break the two unions, remove the trap, put in the spare and tighten the unions. Repairs can then be made in the shop and the repaired trap, with fittings and half unions, put back in stock.

Test Valves (Fig. 10-60) provide an excellent means of checking trap operation. Use a small plug valve. Provide a check valve or shutoff valve in the discharge line to isolate trap while testing.

Figure 10-60.
Typical IB Hookup

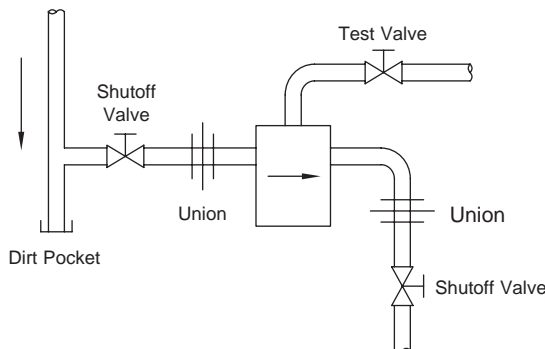
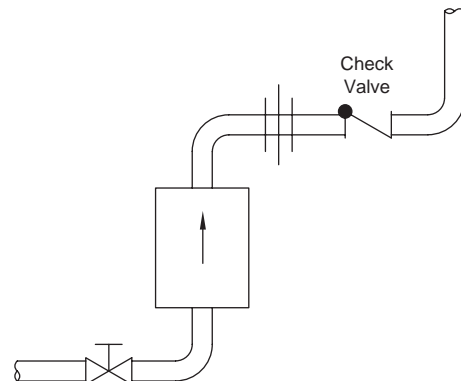

Figure 10-61.
Typical IB Bottom Inlet—Top Outlet Hookup



Installation and Testing of Armstrong Steam Traps

Strainers. Install strainers ahead of traps if specified or when dirt conditions warrant their use. Some types of traps are more susceptible to dirt problems than others—see Recommendation Chart on page 3.

Some traps have built-in strainers. When a strainer blow-down valve is used, shut off steam supply valve before opening strainer blowdown valve. Condensate in trap body will flash back through strainer screen for thorough cleaning. Open steam valve slowly.

Dirt Pockets are excellent for stopping scale and core sand, and eliminating erosion that can occur in elbows when dirt pockets are not provided. Clean periodically.

Syphon Installations require a water seal and, with the exception of the DC, a check valve in or before the trap. Syphon pipe should be one size smaller than nominal size of trap used but not less than 1/2" pipe size.

Elevating Condensate. Do not oversize the vertical riser. In fact, one pipe size smaller than normal for the job will give excellent results.

Check Valves are frequently needed. They are a must if no discharge line shutoff valve is used. Fig. 11-63 shows three possible locations for external check valves—Armstrong inverted bucket traps are available with internal check valves, while disc traps act as their own check valve. Recommended locations are given in Fig. 11-63.

Discharge Line Check Valves prevent backflow and isolate trap when test valve is opened. Normally installed at location B, Fig. 11-63. When return line is elevated and trap is exposed to freezing conditions, install check valve at location A.

Inlet Line Check Valves prevent loss of seal if pressure should drop suddenly or if trap is above drip point in IB traps. Armstrong Stainless Steel Check Valve in trap body, location D, Fig. 11-63, is recommended. If swing check is used, install at location C.

Figure 11-62.
Typical IB Bottom Inlet—Side Outlet Hookup

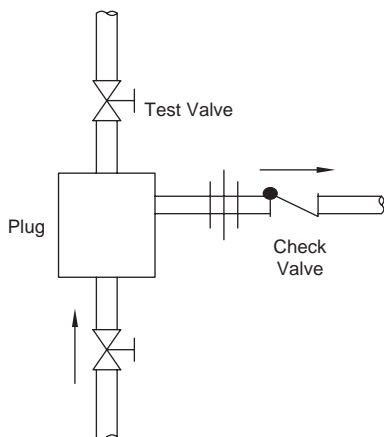

Figure 11-64.
Typical IB By-pass Hookup

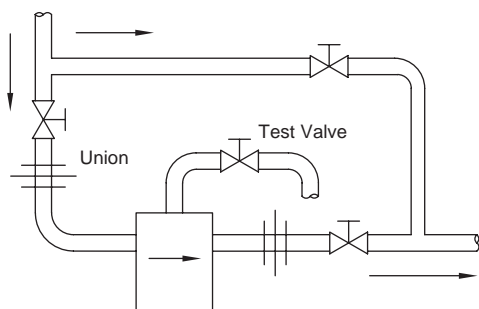

Figure 11-63.
Possible Check Valve Locations

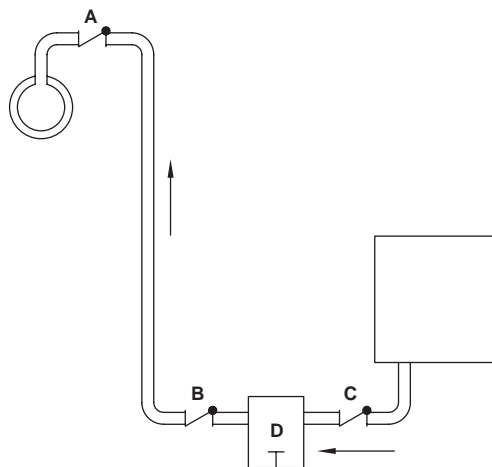
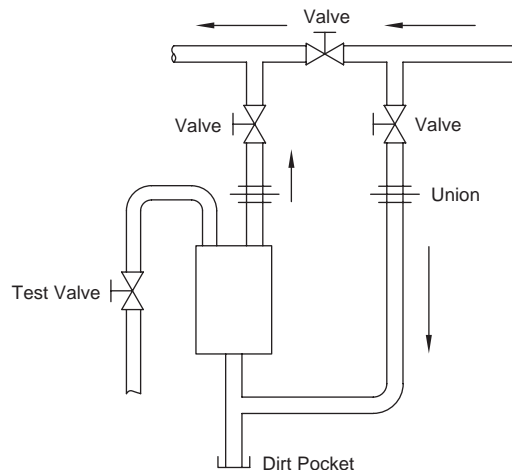

Figure 11-65.
Typical IB By-pass Hookup, Bottom Inlet—Top Outlet





Armstrong® Installation and Testing of Armstrong Steam Traps

A **Safety Drain Trap** should be used whenever there is a likelihood that the inlet pressure will fall below the outlet pressure of a primary steam trap, especially in the presence of freezing air. One such application would be on a modulated pressure heating coil that must be drained with an elevated return line. In the event of insufficient drainage from the primary trap, condensate rises into the safety drain and is discharged before it can enter the heat exchanger. An F&T trap makes a good safety drain because of its ability to handle large amounts of air and its simplicity of operation. Safety drain trap should be same size (capacity) as primary trap.

The proper application of a safety drain is shown in Fig. 12-66. The inlet to the safety drain must be located on the heat exchanger drip leg, above the inlet to the primary trap. It must discharge to an open sewer. The drain plug of the safety drain is piped to the inlet of the primary trap. This prevents the discharge of condensate formed in the safety drain by body radiation when the primary trap is active. The safety drain has an integral vacuum breaker to maintain operation when pressure in the heat exchanger falls below atmospheric. The inlet of the vacuum breaker should be fitted with a gooseneck to prevent dirt from being sucked in when it operates. The vacuum breaker inlet should be provided with a riser equal in elevation to the bottom of the heat exchanger to prevent water leakage when the vacuum breaker is operating, but the drip leg and trap body are flooded.

Protection Against Freezing

A properly selected and installed trap will not freeze as long as steam is coming to the trap. If the steam supply should be shut off, the steam condenses, forming a vacuum in the heat exchanger or tracer line. This prevents free drainage of the condensate from the system before freezing can occur. Therefore, install a vacuum breaker between the equipment being drained and the trap. If there is not gravity drainage through the trap to the return line, the trap and discharge line should be drained manually or automatically by means of a freeze protection drain. Also, when multiple traps are installed in a trap station, insulating the traps can provide freeze protection.

Anti-Freeze Precautions.

1. Do not oversize trap.
2. Keep trap discharge lines very short.
3. Pitch trap discharge lines down for fast gravity discharge.
4. Insulate trap discharge lines and condensate return lines.
5. Where condensate return lines are exposed to ambient weather conditions, tracer lines should be considered.
6. If the return line is overhead, run vertical discharge line adjacent to drain line to top of return header and insulate drain line and trap discharge line together. See Fig. 12-67.

NOTE: A long horizontal discharge line invites trouble. Ice can form at the far end, eventually sealing off the pipe. This prevents the trap from operating. No more steam can enter the trap, and the water in the trap body freezes.

Figure 12-66. Typical Safety Drain Trap Hookup

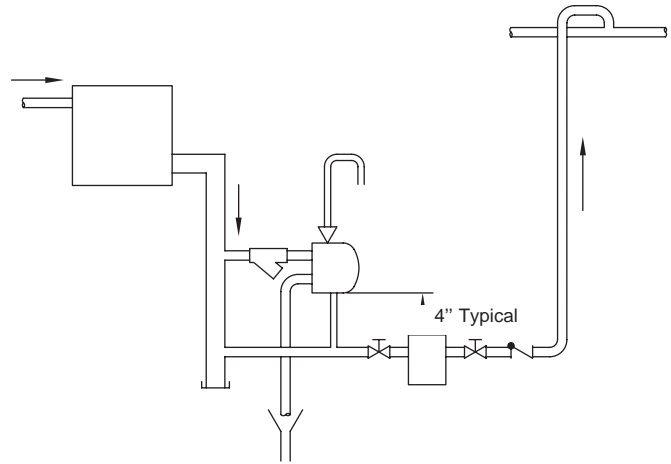
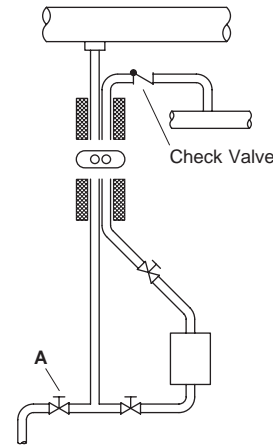
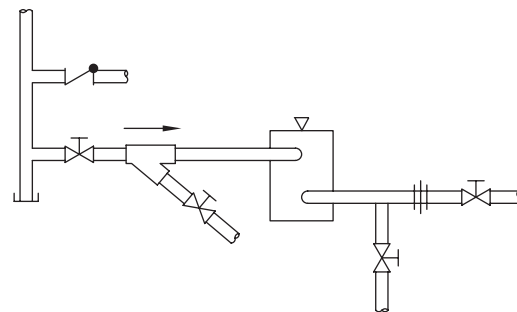

Figure 12-67.



Outdoor installation to permit ground level trap testing and maintenance when steam supply and return lines are high overhead. Drain line and trap discharge line are insulated together to prevent freezing. Note location of check valve in discharge line and blowdown valve **A** that drains the steam main when trap is opened for cleaning or repair.

Figure 12-68. Typical F&T Hookup



Installation and Testing of Armstrong Steam Traps



Testing Armstrong Steam Traps

Testing Schedule.

For maximum trap life and steam economy, a regular schedule should be set up for trap testing and preventive maintenance. Trap size, operating pressure and importance determine how frequently traps should be checked.

Operating Pressure (psig)	Application			
	Drip	Tracer	Coil	Process
0-100	1	1	2	3
101-250	2	2	2	3
251-450	2	2	3	4
451 and above	3	3	4	12

How to Test

The test valve method is best. Fig. 10-60 (page 10) shows correct hookup, with shutoff valve in return line to isolate trap from return header. Here is what to look for when test valve is opened:

1. **Condensate Discharge**—Inverted bucket and disc traps should have an intermittent condensate discharge. F&T traps should have a continuous condensate discharge, while thermostatic traps can be either continuous or intermittent, depending on the load. When an IB trap has an extremely small load it will have a continuous condensate discharge which causes a dribbling effect. This mode of operation is normal under this condition.
2. **Flash Steam**—Do not mistake this for a steam leak through the trap valve. Condensate under pressure holds more heat units-Btu-per pound than condensate at atmospheric pressure. When condensate is discharged, these extra heat units re-evaporate some of the condensate. See description of flash steam on page 5.

How to Identify Flash: Trap users sometimes confuse flash steam with leaking steam. Here's how to tell the difference: If steam blows out continuously, in a "blue" stream, it's leaking steam. If steam "floats" out intermittently (each time the trap discharges) in a whitish cloud, it's flash steam.

3. **Continuous Steam Blow**—Trouble. Refer to page 10 of brochure 871-EN.
4. **No Flow**—Possible trouble. Refer to page 10 of brochure 871-EN.

Listening Device Test. Use a listening device or hold one end of a steel rod against the trap cap and the other end against your ear. You should be able to hear the difference between the intermittent discharge of some traps and the continuous discharge of others. This correct operating condition can be distinguished from the higher velocity sound of a trap blowing through. Considerable experience is required for this method of testing, as other noises are telegraphed along the pipe lines.

Pyrometer Method of Testing. This method may not give accurate results, depending on the return line design and the diameter of the trap orifice. Also, when discharging into a common return, another trap may be blowing through, causing a high temperature at the outlet of the trap being tested. Better results can be obtained with a listening device. Request Armstrong Bulletin 310.

Figure 13-70. Typical Disc Trap Hookup

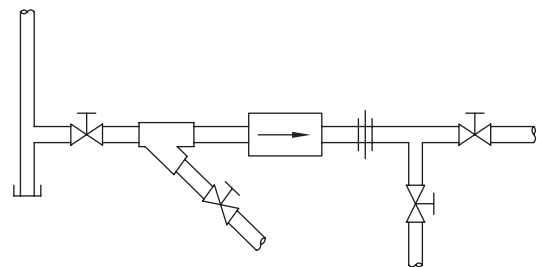

Figure 13-69. Typical DC Hookup

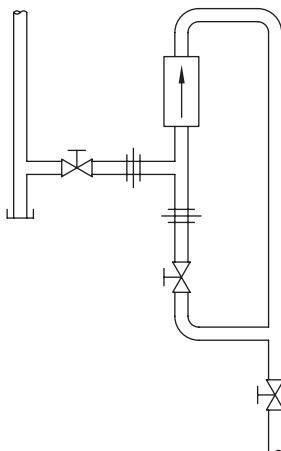
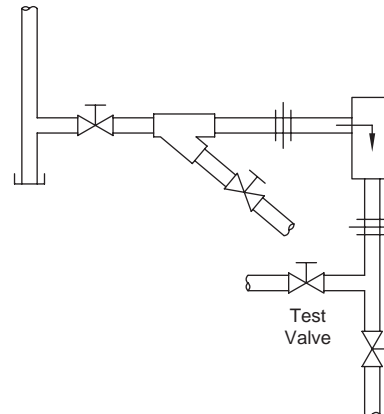

Figure 13-71. Typical Thermostatic Hookup



Armstrong provides intelligent system solutions that improve utility performance, lower energy consumption, and reduce environmental emissions while providing an “enjoyable experience.”



Armstrong International
North America • Latin America • India • Europe / Middle East / Africa • China • Pacific Rim

armstronginternational.com

870-EN
Printed in U.S.A. - 5/15
© 2015 Armstrong International, Inc.