

GP-2000K-1/GP-2000K-3/GP-2000K-6



Air Loaded Valves for Steam

A high performance externally air piloted pressure reducing valve, the GP-2000K-1/GP-2000K-3/GP-2000K-6 is an ideal choice when set point changes are frequent and access to the PRV is difficult. The valve comes totally assembled and requires no field installation except downstream sensing line and air line connection. High Cv, 20:1 turndown ratio and accurate control $\pm 1\%$ of pressure set point from 5% to 100% of flow. A rugged ductile iron body, hardened stainless steel working parts, double stainless steel diaphragms and in-line reparability add up to reliability on the job. Single seated for dead-end service.

For a fully detailed certified drawing, refer to:
GP-2000K CDY #1014
GP-2000K Flanged CDY #1015

GP-2000K-1, GP-2000K-3, GP-2000K-6 Weights								
Size		Weight, lb (kg) [†]						C _v
		NPT		150#		300#		
in	mm	lb	kg	lb	kg	lb	kg	
1/2	15	34	16	36	15	42	19	5.0
3/4	20	34	16	36	15	42	19	7.2
1	25	44	20	48	20	54	23	10.9
1-1/4	32	51	23	53	22	59	25	14.3
1-1/2	40	51	23	55	23	61	26	18.8
2	50	75	34	81	36	84	36	32
2-1/2	65	—	—	142	65	150	65	60
3	80	—	—	155	69	166	72	78
4	100	—	—	247	112	264	119	120
6	150	—	—	507	230	553	252	250

*50% reduced port available for sizes 1/2" - 4". The CV value should be divided by 2 to get reduced port CV.

† For GP-2000K-3 and GP-2000K-6 weights, add 7-1/4 lb. (3.3 kg).

GP-2000K-1, GP-2000K-3, GP-2000K-6 Specifications

Application	Inlet Pressure psig (bar)	Reduced Pressure psig (bar)	Max. Temp. °F (°C)	Minimum Differential psig (bar)	Materials				
					Body	Main Valve/Seat	Pilot Valve/Seat	Diaphragm	Color
Steam	NPT 15 - 300 (1 - 20)	K-1 7 - 125 (.48 - 8.6)	450 (232)	7 (.48)	Ductile Iron ASTM A536	Stainless Steel AISI 420	Stainless Steel AISI 301	Dark Gray	
	150 lb Flanged 15 - 185 (1 - 13)	K-3 30 - 200 (2 - 13.8)							
	300 lb Flanged 15 - 300 (1 - 20)	K-6 45 - 200 (3.1 - 13.8)							

GP-2000K-1, GP-2000K-3, GP-2000K-6 Dimensions

Size	Face-to-Face "L"						A ₁	F	H Integral		H Remote		H ₁	**A ₂					
	NPT		150#		300#				in	mm	in	mm		in	mm	in	mm		
1/2	15	5-15/16	150	5-9/16	141	5-3/4	147	7-15/16	200	6-7/8	175	13-3/16	335	11-13/16	300	6-3/4	170	3-1/4	82
3/4	20	5-15/16	150	5-1/2	140	5-3/4	147	7-15/16	200	6-7/8	175	13-3/16	335	11-13/16	300	6-3/4	170	3-1/4	82
1	25	6-5/16	160	5-3/4	147	6-1/4	159	8-15/16	226	7-1/16	179	13-7/16	341	12	305	6-15/16	175	3-1/4	82
1-1/4	32	7-1/8	180	6-1/2	166	7-1/16	179	8-15/16	226	7-7/16	188	14-5/8	371	12-11/16	322	7-5/8	192	3-1/4	82
1-1/2	40	7-1/8	180	7-7/16	189	7-15/16	202	8-15/16	226	7-7/16	188	14-5/8	371	12-11/16	322	7-5/8	192	3-1/4	82
2	50	9-1/8	230	8-9/16	217	9-1/8	232	10-15/16	276	7-11/16	195	17-1/8	435	13-1/4	337	8-1/2	216	3-1/4	82
2-1/2	65	—	—	10-15/16	278	11-1/2	292	13-13/16	352	8-5/16	211	19-1/4	489	15-3/8	391	9-13/16	251	3-1/4	82
3	80	—	—	11-3/4	298	12-7/16	316	13-13/16	352	8-3/4	222	20-1/8	512	16-3/8	416	10-7/16	264	3-1/4	82
4	100	—	—	13-1/2	343	14-1/8	359	15-13/16	401	9-7/16	239	23-7/16	595	19-7/8	505	12-5/8	321	3-1/4	82
6	150	—	—	18-1/8	460	19	483	19-3/4	502	—	—	29-3/8	746	—	—	27-1/4	692	3-1/4	82

*For GP-2000K-3 and GP-2000K-6 add 1-1/4" (18 mm) to "H" dimension.

**For GP-2000K-3 and GP-2000K-6, A₂ dimension = 6-13/16" (172 mm).

For capacities see page 305.
 For air loading chart see page 301.

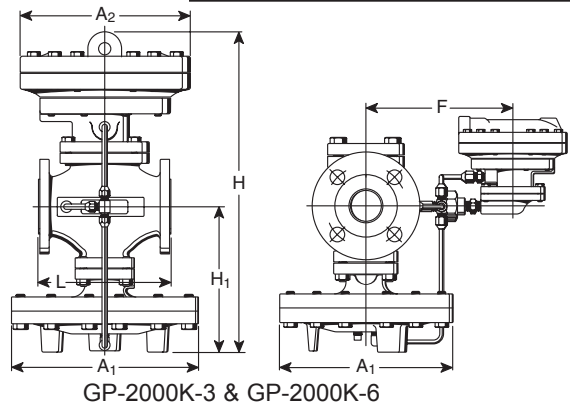
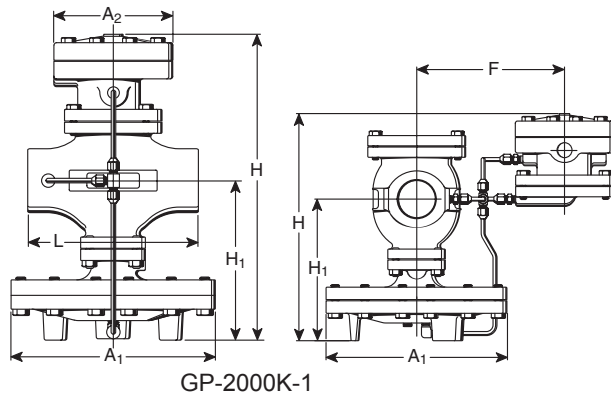

Designs, materials, weights and performance ratings are approximate and subject to change without notice. Visit armstronginternational.com for up-to-date information.

Air Loaded Valves for Steam

The GD-2000K is an ideal choice when set point changes are frequent, access to the valve is difficult and steam quality is poor. The GD-2000K comes with either NPT or flanged connections for quick, easy installation. It also comes with a durable ductile iron body and features double stainless steel diaphragms and hardened stainless working

parts, renewable in-line. High Cv and 10:1 turndown ratio. Single seated for dead-end service.

For a fully detailed certified drawing, refer to:
GD-2000K NPT CDY #1020
GD-2000K Flanged CDY #1021

GD-2000K Specifications

Application	Inlet Pressure psig (bar)	Reduced Pressure psig (bar)	Maximum Temperature °F (°C)	Minimum Differential psig (bar)	Materials			
					Body	Main Valve/Seat	Diaphragm	Color
Steam	NPT 15 - 300 (1 - 20)	7 - 200 (.48 - 13.8)	450 (232)	7 (.48)	Ductile Iron ASTM A536	Stainless Steel AISI 420	Stainless Steel AISI 301	Dark Gray
	150 lb Flanged 15 - 185 (1 - 13)							
	300 lb Flanged 15 - 300 (1 - 20)							

GD-2000K Dimensions and Weights

Size		Face-to-Face						H ₁		H		A		Weight						C _v *		
		NPT		150#		300#								NPT		150#		300#				
in	mm	in	mm	in	mm	in	mm	in	mm	in	mm	in	mm	lb	kg	lb	kg	lb	kg	lb	kg	
1/2	15	5-15/16	150	—	—	—	—	2-7/8	74	9-5/8	244	7-15/16	200	27	13	—	—	—	—	—	—	5.0
3/4	20	5-15/16	150	—	—	—	—	2-7/8	74	9-5/8	244	7-15/16	200	27	13	—	—	—	—	—	—	7.2
1	25	6-5/16	160	—	—	—	—	3-1/16	76	10	251	8-15/16	226	35	17	—	—	—	—	—	—	10.9
1-1/4	32	7-1/8	180	—	—	—	—	3-1/2	90	11-1/8	282	8-15/16	226	43	20	—	—	—	—	—	—	14.3
1-1/2	40	7-1/8	180	—	—	—	—	3-1/2	90	11-1/8	282	8-15/16	226	43	20	—	—	—	—	—	—	18.8
2	50	9-1/8	230	8-9/16	217	9-1/8	232	4-1/2	114	12-5/8	319	10-15/16	276	66	31	72	34	73	34	78	34	32.0
2-1/2	65	—	—	10-15/16	278	11-1/2	292	4-3/4	122	14-3/4	373	13-13/16	352	—	—	135	62	136	62	62	60.0	
3	80	—	—	11-3/4	298	12-7/16	315	5-1/2	140	15-3/4	399	13-13/16	352	—	—	146	67	152	69	78.0	78.0	
4	100	—	—	13-1/2	343	14-1/8	359	6-1/2	167	19-1/4	488	15-13/16	401	—	—	230	105	240	109	120.0	120.0	

*50% reduced port available for sizes 1/2" - 4". The Cv value should be divided by 2 to get reduced port Cv.

**For capacities see page 305.
 For air loading chart see page 301.**

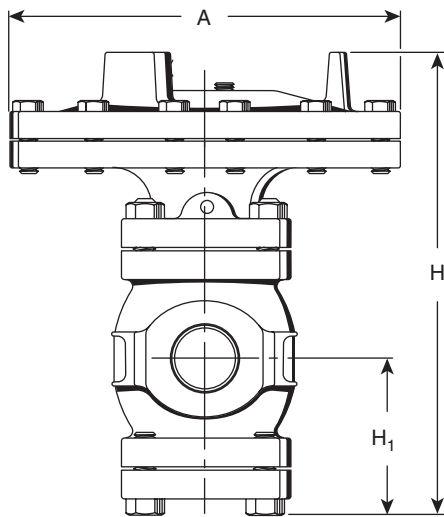

GD-2000K



Air Loading Charts

GP-2000K-1,3,6

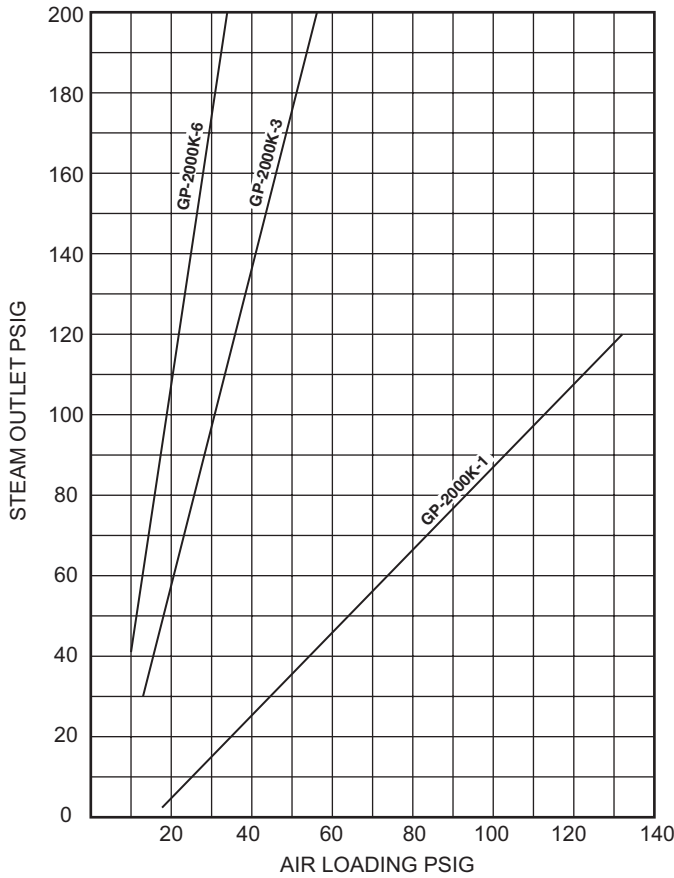

How to Use the Air Loading Charts (GP-2000K-1,3,6)

- Enter the graph at the steam outlet pressure from the value on the vertical axis.
- Move horizontally to the right until the air loading lines are intersected.
- Then read vertically below the point of intersection for the air loading pressure required.

Selection Example (GD-2000K)

Using 1-1/2" GD-2000K
 Steam Inlet Pressure P_1 200 psig
 Steam Outlet Pressure P_2 75 psig
 Differential Pressure ΔP 125 psig

Read horizontally across the bottom of the chart to the 125 psig ΔP line.

Read vertically up to the diagonal line that corresponds to a 1-1/2" GD-2000K.

Read horizontally to the left for additional air signal required.

Outlet Pressure P_2 75 psig
 Additional Air ΔP Air 12 psig
 Total Air Pressure Required 87 psig

Pressure and Temperature Controls

GD-2000K

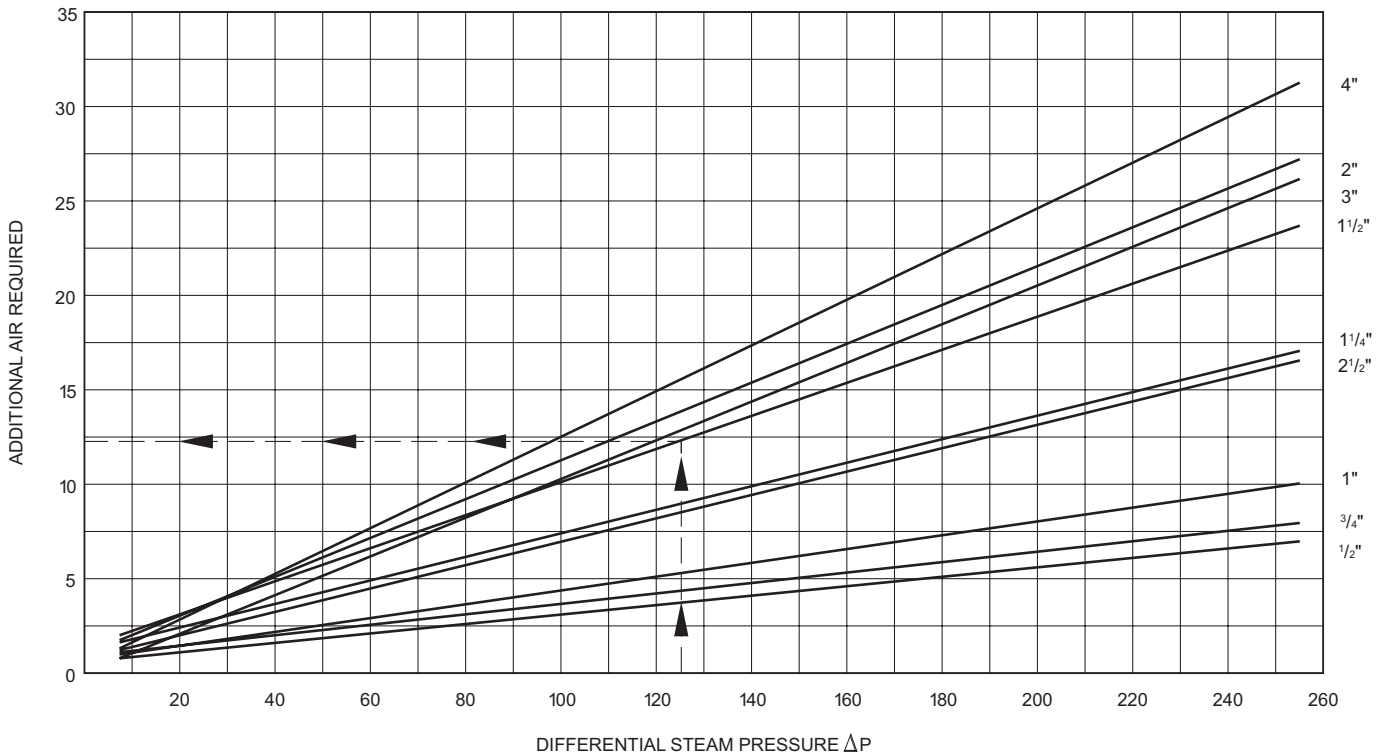

Designs, materials, weights and performance ratings are approximate and subject to change without notice. Visit armstronginternational.com for up-to-date information.