

DIMENSIONS & DATA CERTIFIED FOR:

Representative:

Order:

Customer:

Order:

Project:

Requirements:

By:

Date:

DIMENSIONS & SPECIFICATIONS			
Connection Size	1/4" & 3/8 NPT	1/2" NPT	3/4" NPT
L	2-3/4" [70mm]	2-3/4" [70mm]	3-7/8" [98mm]
H	9-3/8" [238mm]	9-3/8" [238mm]	10-7/8" [276mm]
H ₁	5-3/4" [146mm]	5-3/4" [146mm]	6-3/8" [162mm]
Weight	2-1/2 lbs. [1.1 kgs]	4-1/2 lbs. [2.0 kgs]	4-1/2 lbs. [2.0 kgs]
Cv [Kv]	1.4 [1.2]	1.4 [1.2]	2.6 [2.2]
Inlet Pressure	15-250 psig [1-17 bar]		
Reduced Pressure	5-125 psig [.34-8.5 bar]		
Min. Differential	7 psig [.48 bar]		
Max. Temperature	175 °F [79 °C]		
Application	Air and Other Non-Corrosive Gases		

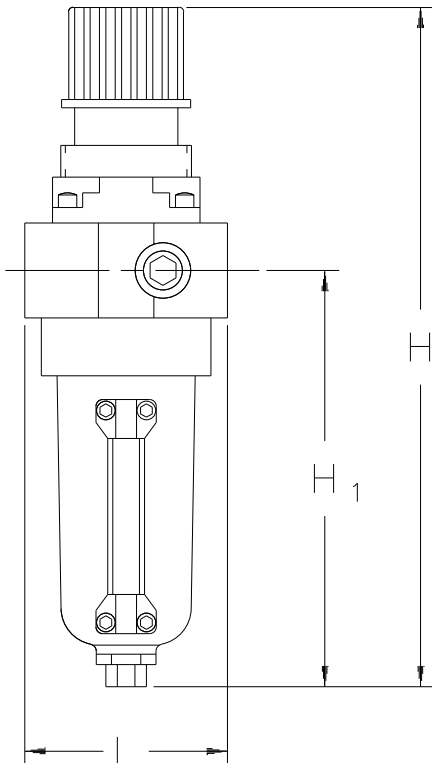

LIST OF MATERIALS	
Body	Zinc
Bowl	Zinc
Main Valve	Zinc
Valve Plug	Brass
Diaphragm	Nitrile



Armstrong Pressure/Temperature Group
 221 Armstrong Blvd.,
 Three Rivers, MI. 49093
Armstrong (269) 279-3600 Fax(269) 273-8656
 Posted on Armstrong's homepage www.armstrong-intl.com

Product	CDY No.	Date
GD-10F PRESSURE REDUCING VALVE	1002	1/16/98
		Rev. B