

DIMENSIONS & DATA CERTIFIED FOR:

Representative:

Order:

Customer:

Order:

Project:

Requirements:

By:

Date:

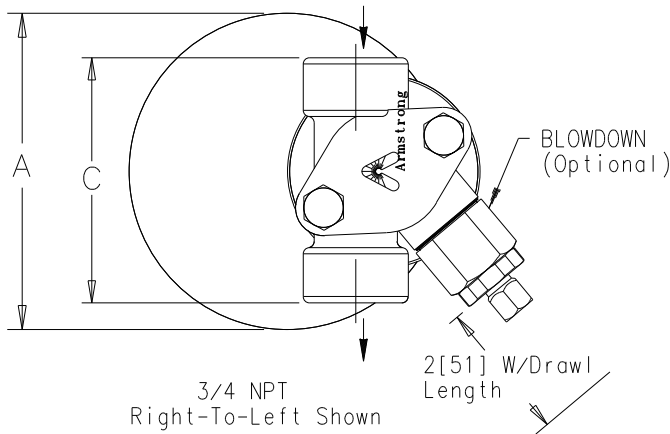
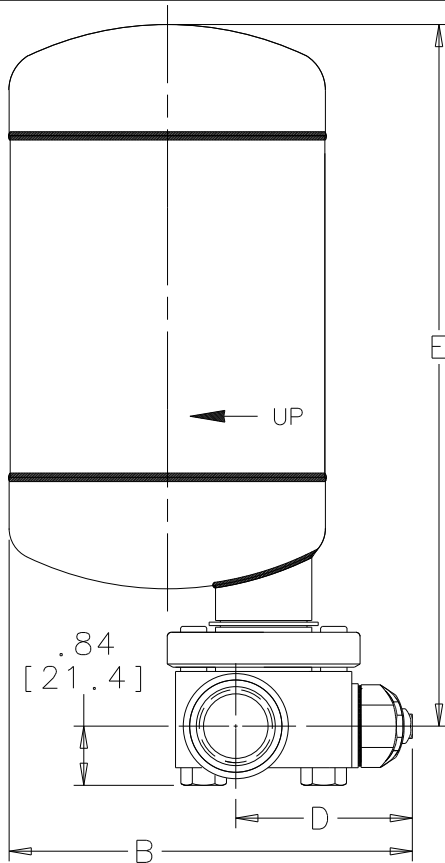

LIST OF MATERIALS:

NAME OF PART	MATERIAL
CAP & BODY	ASTM A240 T304L
SEAT, VALVE	ASTM A582 T303
VALVE	ASTM A564 17-4 PH H900
VALVE RETAINER	ASTM A240 T304
LEVER	
GUIDE PIN ASS'Y	
FLOAT	
CAPSULE	ASTM A582 T303
ADAPTER	
IS-2 CONNECTOR: (May Be Rotated 360°)	
CONNECTOR, STD.	T304 S.S.
CONNECTOR GASKET	T304L S.S. NON-ASBESTOS
RETAINER RING	CARBON STEEL
FLANGE	ASTM A105, ZINK PLATED
FLANGE RETAINER	T304L
BOLT (2)	ASTM A193 Gr. B7

TECHNICAL INFORMATION

MODEL NO.	FT4000	
CONNECTION	1/2[DN15]	1"[DN25]
	3/4[DN20]	
"A" (ø BODY)	4-1/2[114.3]	
"B" (HEIGHT)	5-7/8[149.2]	
"C" (FACE TO FACE)	3-1/2[88.9]	4[101.6]
"D" (ø TO BLOWDOWN)	2-5/8[66.7]	
"E" (ø CONN. TO TRAP EDGE)	10[254]	10-1/4[260.4]
WEIGHT (lbs)	8.7[4 kgs]	9[4.1 kgs]

OPTIONS:

CONNECTION	NPT	
	BSPT	
	SW	
INLET ORIENTATION	RIGHT-TO-LEFT	
	LEFT-TO-RIGHT	

DESIGN INFORMATION

PMA (VESSEL DESIGN)	485 psig @ 600°F [33.4 bar @ 315°C] *
ΔPM _x (MAX. OPERATING psi)	465 psi Sat. Steam *



Product
**FT4000 W/ IS-2 CONNECTOR
 TRAP ASSY**

ENGLISH
 WEB
 Y | N
 ✓ |

CD No.
 1298

Date
 3/26/08

Rev; B

By; paulg