

# DIMENSIONS & DATA CERTIFIED FOR:

Representative:

Order:

Customer:

Order:

Project:

Requirements:

By:

Date:

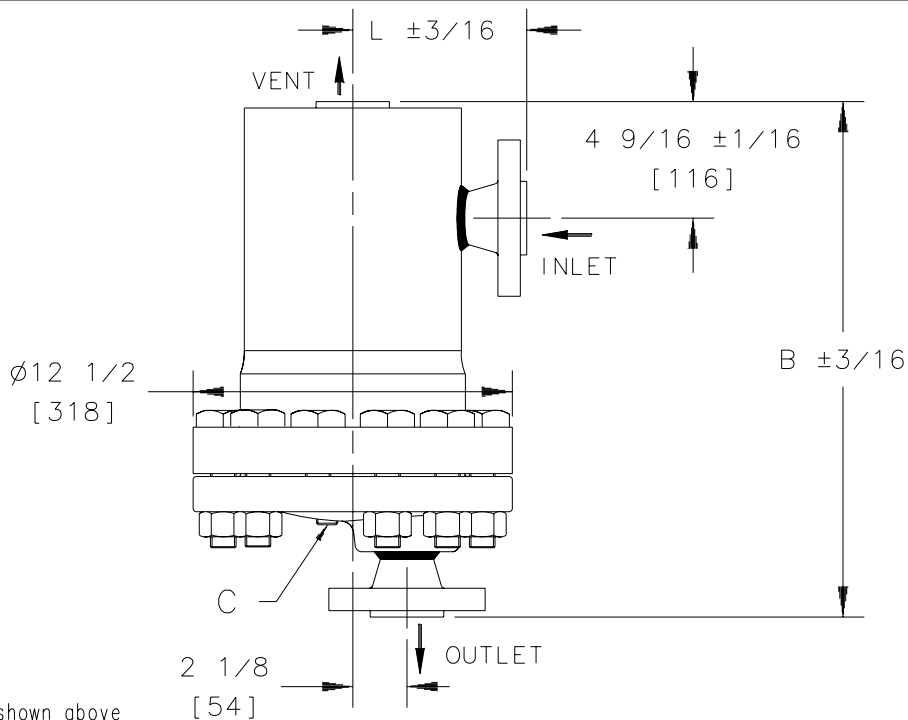

1-1/2" CL. 600 Drainer shown above

DESCRIPTION	DIMENSIONS			
	FLANGE CLASS 600		FLANGE CLASS 900/1500	
CONNECTION (FLG)	1-1/2" [DN40]	2" [DN50]	1-1/2" [DN40]	2" [DN50]
"B" (FACE TO FACE) [mm]	20-3/16" [513]	20-5/16" [516]	20-11/16" [525]	21-7/16" [545]
"C" (PIPE PLUG)	1/2" NPT [DN15]			
"L" (Q OF VENT TO INLET) [mm]	6-13/16" [173]	6-15/16" [176]	7-5/16" [186]	8-1/16" [205]
WEIGHT [kgs]	247 lb [112]	249 lb [113]	257 lb [117]	281 lb [128]
MAXIMUM ALLOWABLE PRESSURE (VESSEL DESIGN)	1800 psig at 100°F [122 bar at 38°C] 600 psig at 900°F [61 bar at 482°C]			

### LIST OF MATERIALS

NAME OF PART	MATERIAL
BODY, CAP & FLANGES	ASTM A182, GR. F22
LEVER MECHANISM & FLOAT	STAINLESS STEEL
VALVE & SEAT	HARDENED STAINLESS STEEL
GASKET	NON-ASBESTOS
BOLT	ASTM A193 GR. B7
NUT	ASTM A194 GR. 2H
PLUG, PIPE	ASTM A108 GR. 1215

FLANGES COMPLY W/ANSI B16.5



Armstrong International, Inc.  
Three Rivers Division  
Three Rivers, MI 49093  
Armstrong (616) 273-1415 Fax(616) 278-6555

Product	CD No.	Date
2416 HLS DRAINER FLG. FORGED STEEL 1-1/2" & 2" CL. 600 & 900/1500	1072	12/2/96
		Rev. A