

1.0 SCOPE

These instructions provide procedures for installing the V150 Verabar flow sensor. Procedures are given for all industrial flow measurement applications including liquid, steam and gas service for both horizontal and vertical piping configurations.

2.0 RECEIVING INSPECTION

The following tasks should be performed as part of the receiving inspection procedure:

- Check items received against the packing list.
- Check sensor nameplate for proper model number, serial number and customer number.
- Verify that the actual pipe diameter matches the ID stated on the sensor nameplate.
- Check the bullet shaped sensor tube for any signs of damage. Damage to the sensor tube may result in erroneous flow readings.
- Check the round cover tube for any damage. Damage to the cover tube may prevent the packing from sealing properly.

3.0 SAFETY PRECAUTIONS

The following tasks should be conducted prior to installing the Verabar flow sensor:

- Check maximum operating conditions on the flow sensor nameplate and verify that they exceed the maximum conditions of the installation. If any pressure, temperature or flow limits will be exceeded, consult the factory before proceeding.

- Check that the pipe is depressurized and drained prior to installation.
- The Spring-Lock Model V150 is designed for carbon and stainless steel pipes with a schedule 10 or heavier wall thickness. The V150 should not be used with PVC, copper, aluminum, cast iron or thin-walled pipes or ducts. If there is any question as to the proper application for a model V150, consult the factory.

4.0 INSTALLATION PREPARATIONS

4.1 Location

For the most accurate flow measurement, a minimum straight run of pipe is required. Table 1 shows the minimum straight run requirements.

If longer straight runs are available, position the Verabar such that the ratio of upstream straight run to downstream straight run is approximately 4 to 1. If straight run lengths are less than the values stated in Table 1, consult the factory for additional accuracy and location information.

Position straightening vanes such that the end closest to the Verabar is half way between the Verabar and the closest upstream configuration. For elbow installations, mount the Verabar in the same plane as the closest upstream elbow.

Piping Configuration	Dimension –A–		Dimension –B–	
	Without Straightening Vanes	With Straightening Vanes		
Elbow		7	7	3
Multiple Elbows in the Same Plane		9	9	3
Multiple Elbows in Different Planes		18	9	3
Reduction in Pipe Size		8	8	3
Increase in Pipe Size		8	8	3
Control Valve		24	9	4

Table 1. Straight Run Requirements

4.2 Orientation

Verify the proper sensor orientation by checking for an “-H” (horizontal piping) or a “-V” (vertical piping) in the model number on the Verabar name plate.

4.2.1 Horizontal Piping

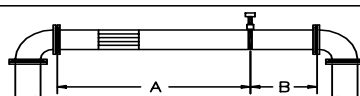
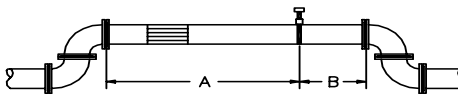
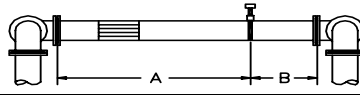
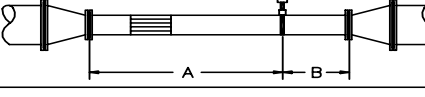
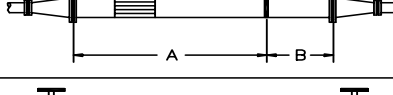
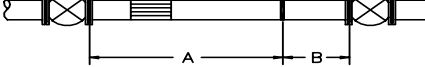
For air or gas installations, mount the Verabar in the upper 160° of the pipe to allow any condensate to drain into the pipe (Figure 1). For liquid or steam installations, mount the Verabar in the lower 160° of the pipe. This allows any entrained air to bleed back into the pipe for liquid applications and allows condensate to collect in the instrument piping for steam applications.

4.2.2 Vertical Piping

The Verabar may be mounted in any location around the circumference of the pipe for vertical piping applications.

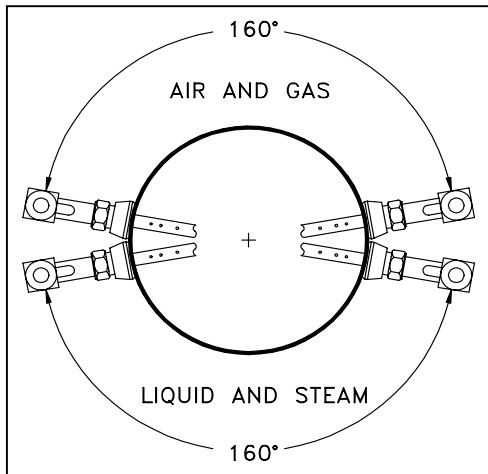

Figure 1. Verabar Orientation in Horizontal Pipe

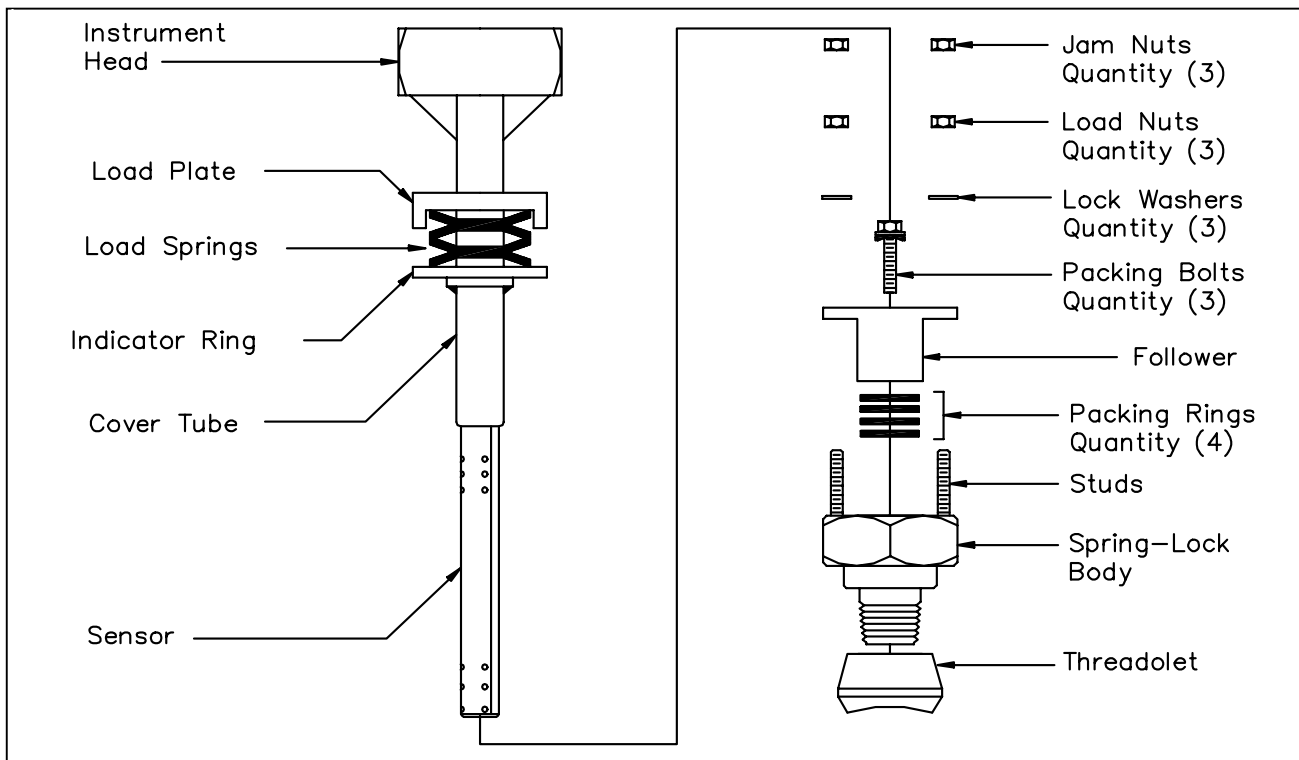

Figure 2. Verabar Model V150

4.3 DP Transmitter/Local Indicator Location

When choosing a Verabar location, consider the DP transmitter/local indicator location:

- The transmitter must be mounted below the Verabar for liquid and steam applications.
- The transmitter must be mounted above the Verabar for air and gas applications.

4.4 Installation Drawings and Bill of Materials

Additional information is available in the Installation Drawings and Bill of Materials VB-7061 (also on the VeraData CD). It contains standard and alternate transmitter locations and a complete bill of materials based on the fluid type and sensor orientation on the pipe.

5.0 INSTALLATION PROCEDURE

5.1 Drill Hole in Pipe

- Completely depressurize and drain the pipe prior to installation of the Verabar.
- Mark the location of the hole through which the Verabar will be mounted. Use a center punch to mark the hole to prevent the drill bit from walking on the pipe.
- Drill the pipe with the proper sized hole per the following table:

Sensor Size	Hole Dia
V150-05	1/2" (13mm)
V150-10	1" (25mm)
V150-15	1-1/2" (38mm)

- Deburr the hole on the inside of the pipe.

5.2 Weld Threadolet to Pipe

- With the follower and packing rings already in place, loosely insert the sensor into the Spring-Lock body (see Figure 2). Thread the Spring-Lock body into the threadolet (hand tight), then insert the complete assembly into the pipe. This will assure proper alignment of the threadolet to the hole already drilled in the pipe.
- Using the appropriate weld gap (1/16" [1.5mm] typical), tack weld the threadolet into position, then remove the sensor and Spring-Lock body. Protect threads on the threadolet and finish welding the threadolet to the pipe per applicable codes (see Figure 3).

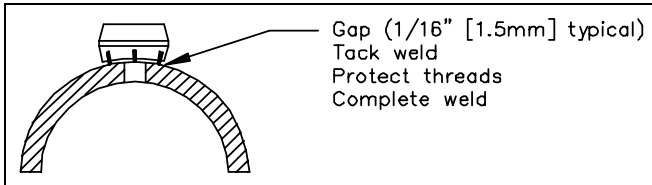

Figure 3. Weld Gap

5.3 Thread Packing Body into Threadolet

Using appropriate pipe thread sealant, thread the Spring-Lock body into the threadolet.

5.4 Insert Sensor

- With the follower and packing rings already in place (factory assembled), insert the sensor into the Spring-Lock body until the tip of the sensor hits the opposite side of the pipe. Note, the three studs must pass through the indicator ring and the load plate.

- Align the head of the sensor so that the arrow labeled "flow" on the head is in the direction of the flow in the pipe to within 3° (Figure 4). Maintain the head in this position for the remainder of the installation.
- Place the three lock washers and the three load nuts on the studs and tighten. Tighten the load nuts until the load plate is 0.050" (1.3mm) from the indicator ring for -05 and -10 sensors. For -15 sensors, the load plate should be 0.063" (1.6mm) from the indicator ring (Figure 6). For -05 sensors, this can be done by tightening all the load nuts until the load plate just touches the indicator ring and then backing off all the load nuts one complete turn. For -10 and -15 sensors, this can be done by tightening all the load nuts until the load plate just touches the indicator ring and then backing off all the load nuts 3/4 of a turn. The load springs are now properly set.
- Thread on the three jam nuts and tighten until they are resting hand-tight against the lock nuts. Place a backup wrench on the load nut to prevent it from rotating. While not allowing the load nut to rotate, tighten the jam nuts 1/8 turn beyond hand tight.

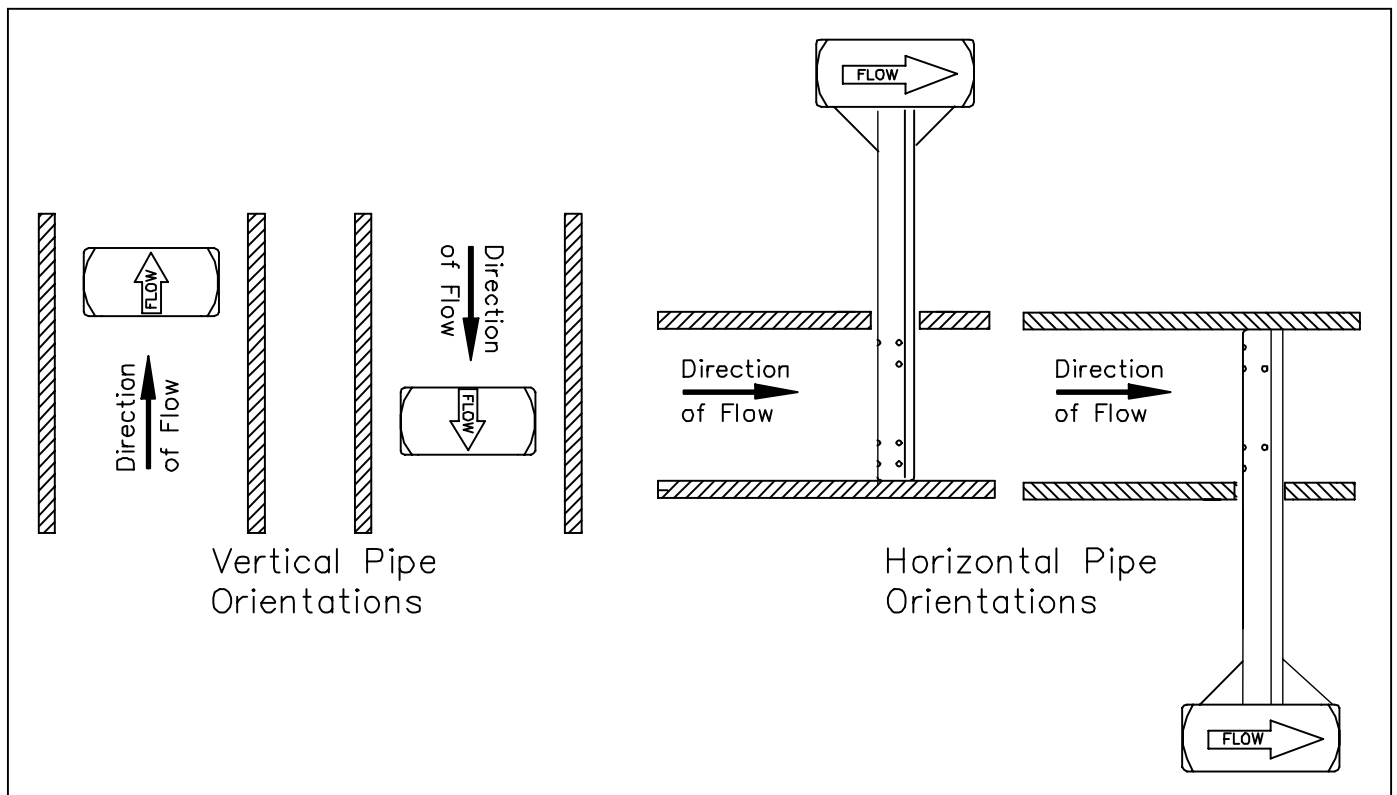

Figure 4. Orientation of Flow Arrow

- Using a torque wrench, tighten the three packing bolts to the appropriate torque value listed in the table below.

Sensor Size	Packing Bolt Torque (in-lbs)	Packing Bolt Torque (ft-lbs)
-05	50	4.2
-10	100	8.3
-15	170	14.1

Note: The weld on the weld ring (Figure 6) should not contact the top surface of the follower. If the weld on the weld ring comes into contact with the follower, the sensor will not be properly bottomed in the pipe. If this occurs, consult the factory before proceeding.

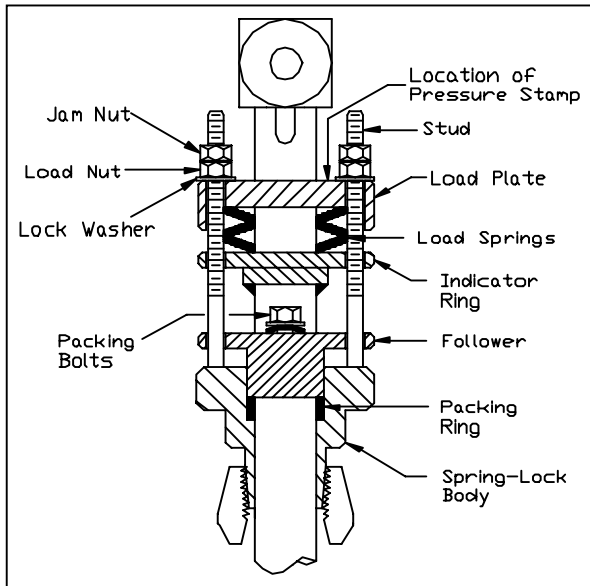

Figure 5. Spring-Lock Cut Away

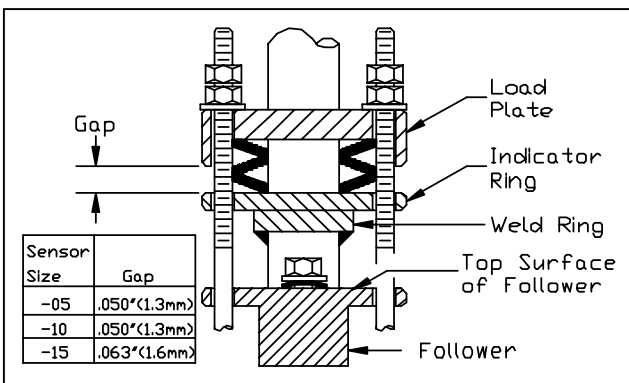

Figure 6. Proper Spring Compression

5.5 Install Instrument Valves or Manifold

5.5.1 Valves

If the Verabar does not have a valve head, install instrument valves using proper thread sealant. Be sure instrument shut-off valves are installed and shut prior to repressurizing the pipe.

5.5.2 Manifold

If the Verabar has a direct or integral manifold, be sure the high and low-pressure block valves are shut off prior to repressurizing the pipe.

5.6 Pressurize Pipe and Retighten Bolts

Pressurize the pipe and check for leaks. If leaks are present, retighten the packing bolts until leaking is eliminated. Verify that the distance between the load plate and the indicator ring is approximately 0.050" (1.3mm) for -05 and -10 sensors and 0.063" (1.6mm) for -15 sensors; make adjustments as required.

The Verabar is now properly installed (Figure 7).

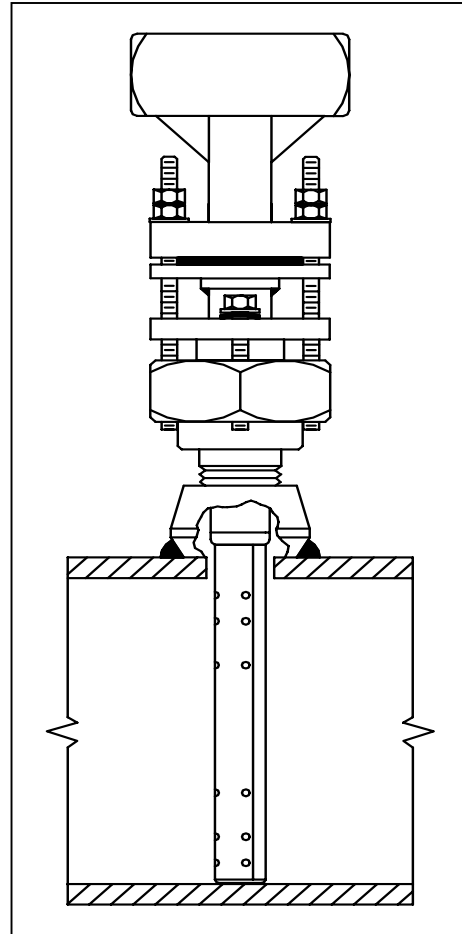

Figure 7. Installed V150

Periodic Maintenance

The assembly should be periodically checked. Verify that no leaks are present. Tighten the packing bolts if necessary.