



## SH-1500 Series Superheat Traps

### Bimetallic Steam Traps for Superheat Conditions

Armstrong's SH-1500 Series Bimetallic Steam Trap for superheat or low load conditions, is the ideal trap for applications where other trap styles are not suitable for long life.

#### Advantages:

- Compact
- Lightweight
- High temperature capabilities
- Long service life on superheat
- Easy in-line repairability
- Fail open design
- Resists water hammer
- Multiple pipe sizes & connections available
- Integral strainer
- Large start-up capacity
- Quiet discharge
- Forgiving of piping errors

The Armstrong SH-1500 series bimetallic trap also has the ability to handle the large start-up loads associated with superheat applications. The unique bimetallic element allows for tight shut-off before superheat reaches the trap thus preventing steam loss. The SH-1500 series utilizes a titanium valve and seat to ensure extremely long service life in the harsh environment of superheated steam systems.

#### Specifications:

The steam trap shall be an Armstrong bimetallic style. The trap shall be investment cast chrome-moly steel (Model SH-1500) with integral stainless steel strainer, in-line repairable. The mechanism shall consist of a stacked nickel-chrome bimetal operator, with titanium valve and seat. The steam trap shall be capable of operation on low load and superheat applications throughout its pressure/temperature range.

#### Maximum Operating Conditions:

Maximum allowable pressure (vessel design)  
1800 psig @ 1050°F (124 bar @ 500°C)

Maximum operating pressure  
1800 psig (124 bar)

Suggested minimum operating pressure  
600 psig (41 bar)

#### Connections:

Socketweld, Buttweld and Flanged

#### Materials:

Body and cap: ASTM 217 Gr. C12A  
Valve and seat: Titanium  
Elements: Ni-Cr and stainless steel  
Strainer: Stainless steel screen

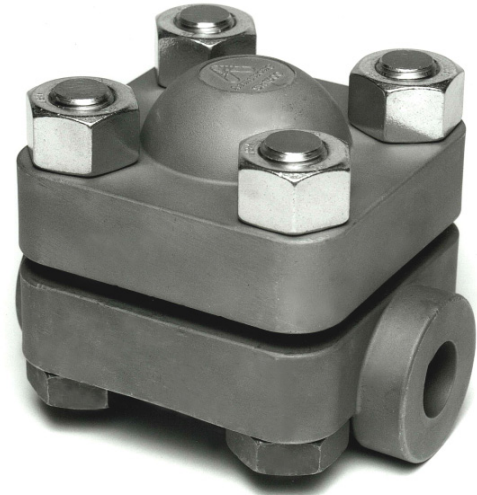

#### How to order:

Specify:

- Model number
- Size and type of pipe connection. When flanges are required, specify type of flange in detail.

# SH-1500 Series Superheat Traps

## Bimetallic Steam Traps for Superheat Conditions



SH-1500 Series Superheat Steam Traps		
Model	SH-1500	
	in	mm
Pipe Connections	3/4", 1"	20, 25
"A" Height	5	127
"B" Face-to-Face	6-1/4	158
"C" C to Top	3-13/16	97
"D" Width	4-7/8	124
* "E"	12	305
* "F"	6-3/8	162
Weight, lb (kg)	15 (6.8)	

\* Dimensions "E" and "F" are for 3/4" connection, Class 1500 Flanged. Consult factory for dimensions of models with other connection sizes and/or flanges.

SH-1500

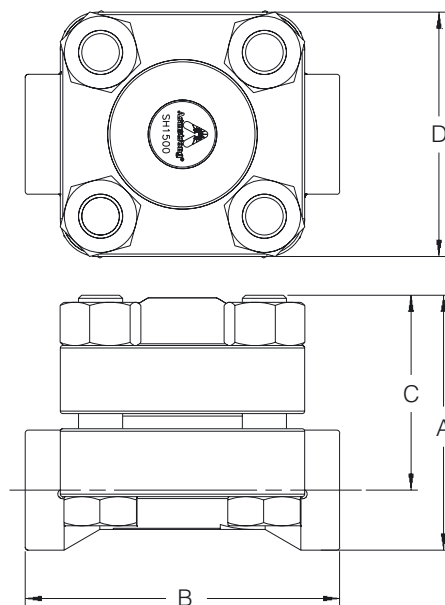

SH-1500 Flanged

