

SH-4000 Series Bimetallic Steam Traps

All Stainless Steel

For Pressures to 86 bar ... Cold Water Start-up Capacities to 2 722 Kg/h



Armstrong's SH-4000 Bimetallic Steam Trap is the ideal design for applications involving superheated steam.

During start-up, the bimetallic mechanism is fully open and allows large volumes of non-condensable gases and condensate to be removed from the system. As the system reaches saturated steam conditions, the mechanism begins to close preventing any live steam loss. The superheat during normal operating steam conditions keep the valve closed to ensure long service life.

In the event that operating conditions change and condensate forms at the steam trap inlet, the cooling effect allows the bimetallic mechanism to open and discharge any accumulation. The valve quickly closes once normal operating conditions return.

The SH-4000 consists of an investment cast, stainless steel body that is compact and highly resistant to harsh, corrosive environments. The integral mounting flange is compatible with the Armstrong IS-4, 4-bolt, Class 900, connector making for labor savings and easy steam trap replacement.



Steam Trapping and Steam Tracing Equipment

Maximum Operating Conditions

Maximum allowable pressure (vessel design):
86 bar @ 482°C (1245 psig @ 900°F)

Maximum operating pressure:

SH-4009L	45 bar @ 482°C (650 psig @ 900°F)
SH-4009H	62 bar @ 482°C (900 psig @ 900°F)
SH-4015	86 bar @ 482°C (1245 psig @ 900°F)

Materials and Weight

Body:	ASTM A351 Gr. CF8M
Valve & Seat Elements:	Titanium Ni-Cr Stainless Steel
Spiral Wound Gasket:	Stainless Steel
Bolts:	ASTM A193 B7
Weight:	1,7 kg (3,75 lbs)

Specification

Steam traps shall be a bimetallic style designed for superheated steam applications. The steam trap body shall be tamperproof, investment cast stainless steel A351 Gr. CF8M. The mechanism shall consist of a stacked nickel-chrome bimetal operator with titanium valve and seat. The gaskets shall be captured stainless steel spiral wound. The steam trap shall be compatible with the 4-bolt universal connector technology.

How to Order

Specify model number
Maximum working pressure and temperature

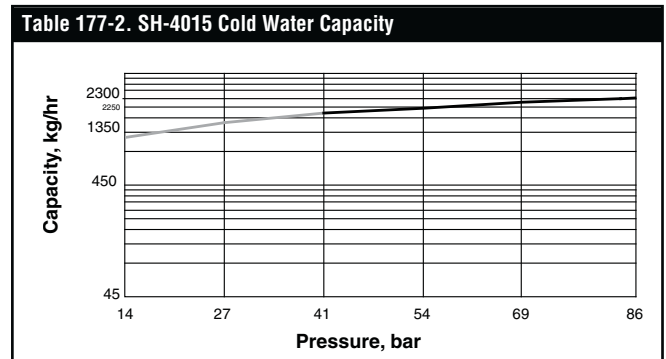
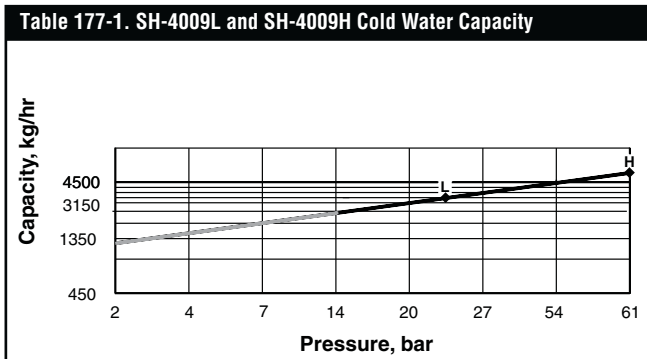
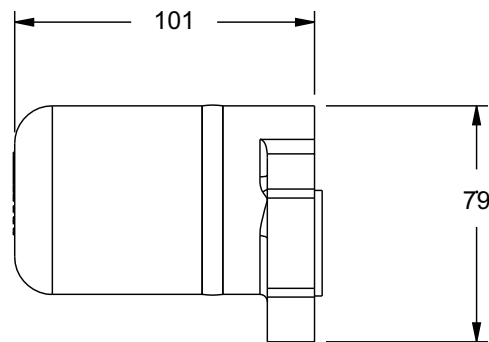
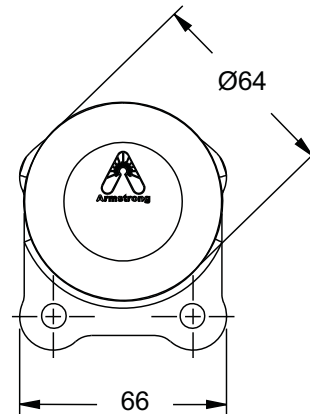

Note: Cold water capacity for start-up loads only. When superheat present, there will be minimal condensate. Grey curve indicates that trap can not be used in this area.

All dimensions and weights are approximate. Use certified print for exact dimensions. Design and materials are subject to change without notice.