



2000 Series Stainless Steel Steam Traps

The Armstrong stainless steel traps – Series 1000, Series U-1000, Series 1800 and Series 2000 – have high resistance to damage from freeze-ups. They also offer high resistance to wear and corrosion for longer service reliability, and they provide continuous air venting.

Armstrong stainless steel traps provide maximum ease and economy of installation, inspection or replacement. What's more, an Armstrong stainless steel trap is the ideal solution for trapping applications such as tracer lines, steam mains and heating and processing applications.

Steam Trapping and
Steam Tracing Equipment

Wear and corrosion resistance

Free-floating guided lever valve mechanism is "frictionless," and all wear points are heavily reinforced. All working parts are stainless steel. Valve and seat are stainless steel, individually ground and lapped together in matched sets.

Virtually no steam loss

Steam does not reach the water-sealed discharge valve.

Purging action

Snap opening of the valve creates a momentary pressure drop and turbulence in the unit drained. This breaks up films of condensate and air and speeds their flow to the trap.

Sealed, tamperproof 304-L stainless steel package

Able to withstand freeze-ups without damage.

Excellent operation against back pressure

Since trap operation is governed by the difference in density of steam and water, back pressure in the return line has no effect on the ability of the trap to open for condensate and close against steam.

360° universal 304 stainless steel connector

Provides quick, easy in-line renewability along with all the proven advantages of an inverted bucket operation. Also available with optional IS-2 integral strainer connector with 20 x 20 mesh stainless steel strainer.

Continuous air and CO₂ venting

Vent in top of bucket provides continuous automatic air and CO₂ venting with no cooling lag or threat of air binding. Steam passing through vent is less than that required to compensate for radiation losses from the trap, so it's not wasted.

Dependable operation

Simple, direct operation with nothing to stick, bind or clog. Only two moving parts – the valve lever and the bucket.

Freedom from dirt problems

Condensate flow under the bottom edge of the bucket keeps sediment and sludge in suspension until it is discharged with the condensate. Valve orifice opens wide and closes tightly. No buildup of dirt or close clearances to be affected by scale.

Resistance to damage from water hammer

Open bucket or float will not collapse as a result of water hammer.

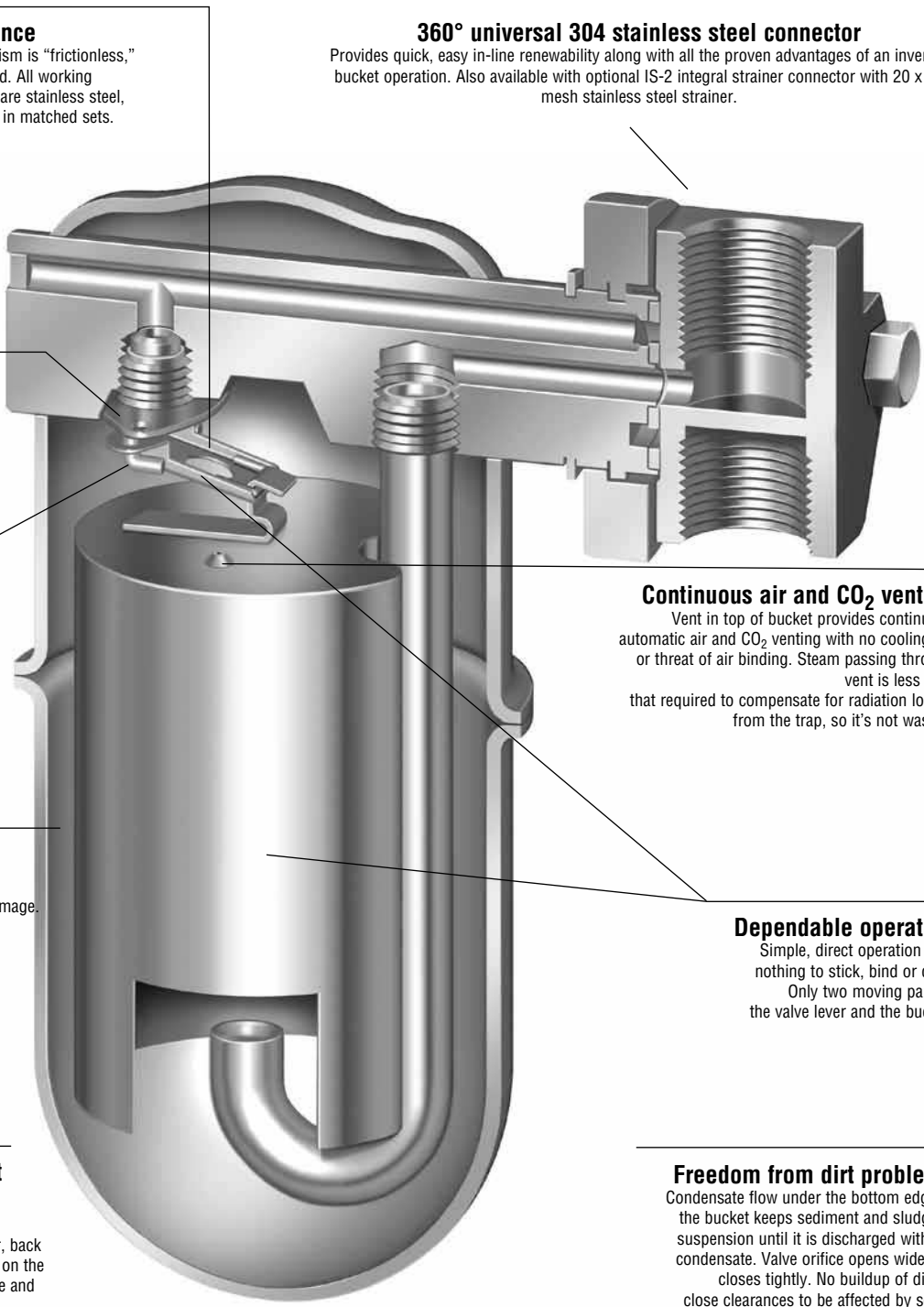

2000 Series Stainless Steel Steam Traps

For Pressures to 45 bar...Capacities to 590 kg/h

With the Series 2000 360° universal connector, you can install inverted bucket efficiency and long service life in any piping configuration with little or no repiping. You get the reliability of the inverted bucket operating principle, plus all the benefits of all-stainless steel construction:

- A sealed, tamperproof package
- A compact, lightweight trap
- The ability to withstand freeze-ups without damage
- Exceptional corrosion resistance
- A three-year guarantee against defective materials or workmanship

Series 2000 steam traps combine savings in three important areas: energy, installation and replacement. The 360° universal connector provides quick, easy in-line renewability along with all the proven advantages of an inverted bucket operation. Choice of NPT or BSPT screwed connections, or socketweld connections.

Also available with optional IS-2 integral strainer connector.



Available with Standard Connector
Material: 304 Stainless Steel



Available with
IS-2 Integral Strainer Connector
(shown with optional blowdown valve)
Material: 304 Stainless Steel



Available with
IS-4 Connector
Material: ASTM A351 Gr. CF8M



2000 Series Inverted Bucket Steam Traps

All Stainless Steel with 360° Connector
For Pressures to 45 bar...Capacities to 590 kg/h

Description

With the 2000 Series' 360° universal connector, you can install inverted bucket efficiency and long service life in any piping configuration with little or no repiping. You get the reliability of the inverted bucket operating principle, plus all the benefits of all-stainless steel construction:

- A sealed, tamperproof package
- A compact, lightweight trap
- The ability to withstand freeze-ups without damage
- Exceptional corrosion resistance
- A **three-year guarantee** against defective materials, defective workmanship.

2000 Series steam traps combine savings in three important areas: energy, installation and replacement. The 360° universal connector provides quick, easy in-line replacement along with all the proven advantages of inverted bucket operation. Also available with optional IS-2 integral strainer connector.

Maximum Operating Conditions

Maximum allowable pressure (vessel design)†:

Model 2010, 2011: 28 bar @ 427°C
Model 2022: 45 bar @ 315°C

Maximum operating pressure:

Model 2010: 14 bar
Model 2011: 28 bar
Model 2022: 45 bar @ 316°C
43 bar @ 371°C
41,6 bar @ 427°C

Maximum back pressure: 99% of inlet pressure

Connections

Screwed BSPT and NPT
Socketweld
Flanged DIN or ANSI (welded)

Materials

Body: ASTM-A 240 Grade 304L
Loose Flange: Zinc Plated Steel
Internals: All stainless steel – 304
Valve and seat: Stainless Steel 17-4PH (<35 bar)
Titanium (>35 bar)
Stainless steel – 304
Standard connector: IS-2 connector with integral strainer: ASTM A351 Gr.CF8
20 x 20 mesh 304 SS Screen

Specification

Inverted bucket steam trap, type ... in all stainless steel, freeze resistant, with 360° universal connector, having continuous air venting at steam temperature, free-floating stainless steel mechanism, and orifice at the top of the trap.
Maximum allowable back pressure 99% of inlet pressure.

How to Order

Specify:

- Model number
- Size and type of pipe connection
- Type of 360° connector (with or without strainer)
- Maximum working pressure that will be encountered or orifice size
- Any options required

Options

- Insu-Pak™ insulation for Models 2010/2011
- Stainless steel pop drain for Models 2011/2022
- Stainless steel loose flange
- Probe connection for Models 2011/2022
- Standard connector
- IS-2 connector with integral strainer
- With the 2000N Series 360° universal connector, copper oxide plugging problems can be eliminated.

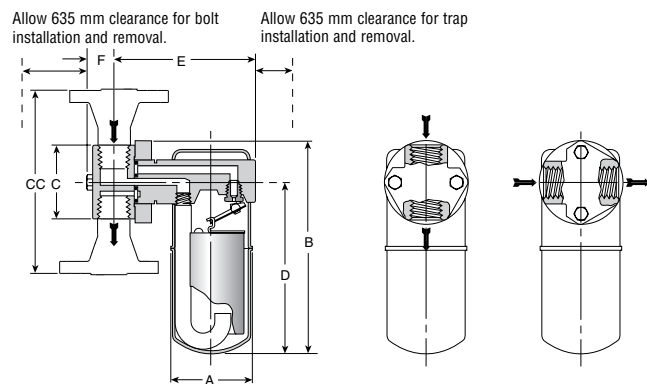

Model 2011 Trap with Standard Connector

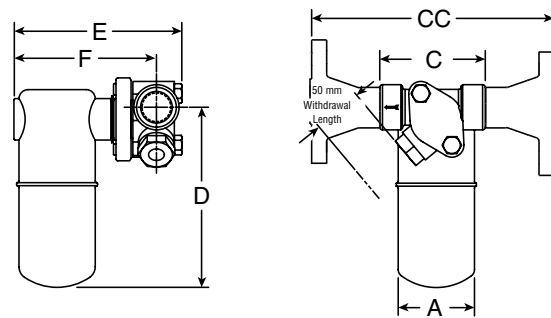

Model 2010-2022 with IS-2 Connector

Table ST-112-1. 2000 Series Traps with Standard Connector

Model No.	2010	2011	2022
Pipe Connections	15 – 20 – 25		
"A" Body Outside Diameter	68	68	98
"B" Height**	152	176	221
"C" Face-to-Face (screwed & SW)	60	60	60
"CC" Face-to-Face (flanged PN40*)	150 – 150 – 160		
"D" Bottom to \varnothing Inlet	117	142	187
"E" \varnothing to Outside (Standard)***	116	116	146
"F" \varnothing to Bolt	25	25	25
Weight in kg (screwed & SW)	1,9	2,0	3,0
Weight in kg (flanged PN40*)	3,6 – 4,2 – 4,7	3,7 – 4,3 – 4,8	4,7 – 5,3 – 5,7

Table ST-112-1. 2000 Series Traps with IS-2 Integral Strainer Connector

Model No.	2010		2011		2022	
Pipe Connections	15 – 20	25	15 – 20	25	15 – 20	25
"C" Face-to-Face (screwed & SW)	89	102	89	102	89	102
"CC" Face-to-Face (flanged PN40*)	150	160	150	160	150	160
"D" Bottom to \varnothing Inlet**	127	127	152	152	197	197
"E" Outside to Bolt	140	144	140	144	170	175
"F" \varnothing to Outside	117	122	117	122	148	152
Weight in kg (screwed & SW)	2,2	2,4	2,3	2,5	3	3
Weight in kg (flanged PN40*)	3,9 – 4,5	5,1	4,0 – 4,6	5,2	4,7 – 5,3	5,7

* Standard flanges are in carbon steel, stainless steel flanges are optional. Other flange sizes, ratings and face-to-face dimensions are available on request.

** For IS-2 connector, add 15 mm to "B" and "D" dimensions when optional probe connections is required.

*** When trap is installed in vertical position on flanged connector, the "Export - Long Neck" version should be used.

All models comply with the Article 4.3 of the PED (2014/68/UE).

† May be derated depending on flange rating and type.

All dimensions and weights are approximate. Use certified print for exact dimensions. Design and materials are subject to change without notice.

Armstrong International SA • Parc Industriel des Hauts-Sarts (2^e Avenue) • 4040 Herstal • Belgium

Tel.: +32 (0)4 240 90 90 • Fax: +32 (0)4 240 40 33

www.armstronginternational.eu • info@armstronginternational.eu

2000 Series Inverted Bucket Steam Traps

All Stainless Steel with 360° Connector
For Pressures to 45 bar...Capacities to 590 kg/h



Table ST-113-1. Model 2010 Capacity

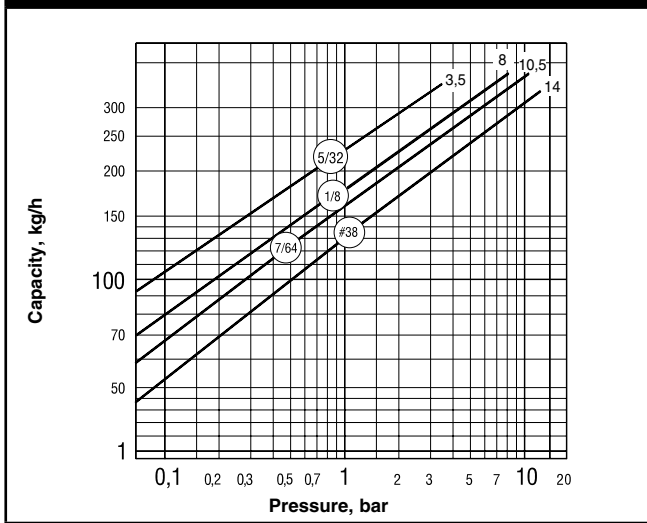
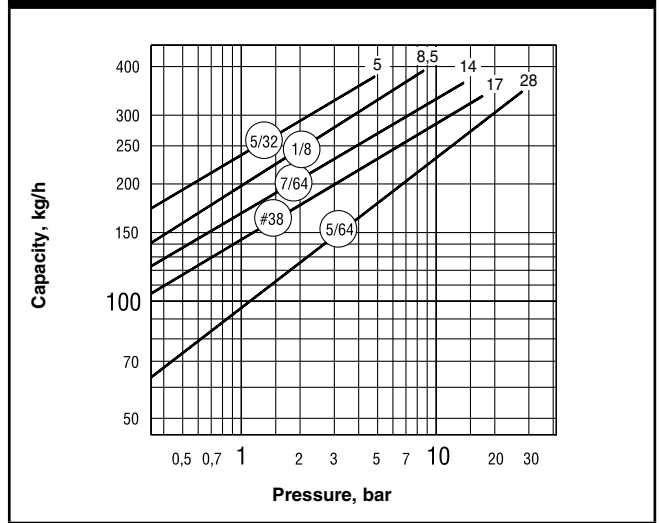

Table ST-113-2. Model 2011 Capacity



Connectors

Besides the inverted bucket traps, the standard connector, IS-2 connector with integral strainer and TVS-4000 can also be used on thermostatic, thermostatic wafer and disc traps.



Options

Pop Drain for Freeze Protection

In general, a properly selected and installed Armstrong trap will not freeze as long as steam is coming to the trap. If the steam supply is shut off, a pop drain should be used to automatically drain the trap. Stainless steel pop drain available for Models 2011 and 2022.

Maximum Operating Conditions

Pressure: 41 bar
Temperature: 177°C

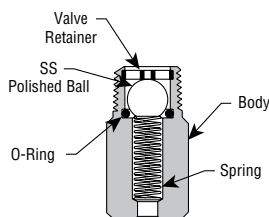
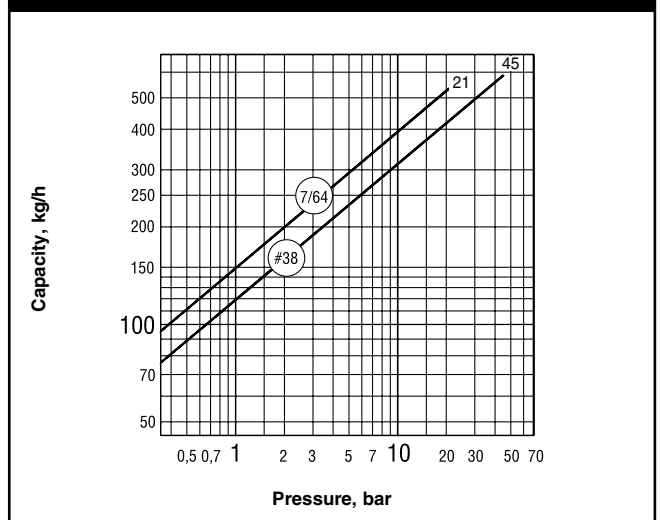

Table ST-113-3. Model 2022 Capacity



Insu-Pak™

Now you can insulate the in-line traps in your plant without complicating regular trap maintenance. Insu-Pak, a simple reusable insulation package, cuts the time and cost of in-field installation because it goes on in a snap. And it comes off just as easily. The Insu-Pak can prevent trap freeze-up when used with a properly designed condensate manifold. Designed for use with Model 2010 and Model 2011 traps.

Probe connections are available for trap monitoring for Models 2011 and 2022.



All dimensions and weights are approximate. Use certified print for exact dimensions. Design and materials are subject to change without notice.

Steam Trapping and Steam Tracing Equipment