

200 Series Inverted Bucket Steam Traps

Cast Iron for Vertical Installation

For Pressures to 17 bar...Capacities to 9 000 kg/h

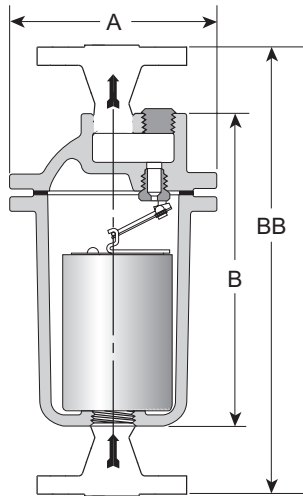

Description

The most reliable steam trap known – the inverted bucket – provides efficient condensate drainage of virtually all types of steam-using equipment. Put the inverted bucket to work in a tough cast iron package, and you have the best of both worlds. Because they operate efficiently for longer periods of time, Armstrong cast iron inverted buckets add solid energy savings to lower replacement/labor costs.

A unique leverage system multiplies the force provided by the bucket to open the valve against system pressure. The mechanism is free-floating, and has no fixed pivots to create wear or friction.

Because the mechanism is located at the top of the trap, no dirt can collect on the orifice. Small particles of dirt are held in suspension until discharged by the full differential purging action when the bucket sinks, pulling the valve off the seat.

The discharge orifice is surrounded by a water seal, preventing live steam loss. Automatic air venting is provided by a small vent hole in the bucket, which provides continuous automatic air and CO₂ venting at steam temperature.

Inverted bucket traps drain continuously, although discharging intermittently, allowing no condensate backup. They are also resistant to water hammer.

Maximum Operating Conditions

Maximum allowable pressure
(vessel design): 17 bar @ 232°C
Maximum operating pressure: 17 bar
Maximum back pressure: 99% of inlet pressure

Connections

Screwed BSPT and NPT
Flanged DIN or ANSI (screw on)

Materials

Body: ASTM A48 Class 30
Cap: ASTM A48 Class 30
ASTM A-105 (Only 215 if PMO > 9 bar)
Internals: All stainless steel – 304
Valve and seat: Hardened chrome steel – 440F
Test plug: Carbon steel

Options

- Stainless steel internal check valve
- Thermic vent bucket
- Scrub wire

Specification

Inverted bucket steam trap, type ... in cast iron, with continuous air venting at steam temperature, free floating stainless steel mechanism, and discharge orifice at the top of the trap. Maximum allowable back pressure 99% of inlet pressure.

How to Order

- Specify:
- Model number
 - Size and type of pipe connection
 - Maximum working pressure that will be encountered or orifice size
 - Any options required

Table ST-74-1. 200 Series, Bottom Inlet, Top Outlet Trap (dimensions in mm)
Add suffix "CV" to model number for internal check valve, "T" for thermic vent bucket.

Model No.	211	212	213	214	215	216
Pipe Connections	15	15 – 20	15 – 20 – 25	25 – 32	25 – 32 – 40	40 – 50
Test plug	1/8"	3/8"	1/2"	1/2"	3/4"	1"
"A" Flange Diameter	108	133	162	190	216	259
"B" Face-to-Face (screwed)	162	203	273	317	364	432
"BB" Face-to-Face (flanged PN40*)	282	320 - 330	390 - 400 - 392	436 - 440	484 - 494 - 494	562 - 568
Number of Bolts	6	8	6	8	8	12
Weight in kg (screwed)	2,7	5,2	9,2	15,0	20,3	35,2
Weight in kg (flanged PN40*)	4,1	7,0 – 7,6	11 – 11,6 – 12	18,6 – 20,2	21 – 22,7 – 23	39,6 – 41,2

* Other flange sizes, ratings and face-to-face dimensions are available on request.

Shade indicates products that are CE Marked according to the PED (97/23/EC). All the other models comply with the Article 3.3 of the same directive.

All dimensions and weights are approximate. Use certified print for exact dimensions. Design and materials are subject to change without notice.

200 Series Inverted Bucket Steam Traps

Cast Iron for Vertical Installation

For Pressures to 17 bar...Capacities to 9 000 kg/h

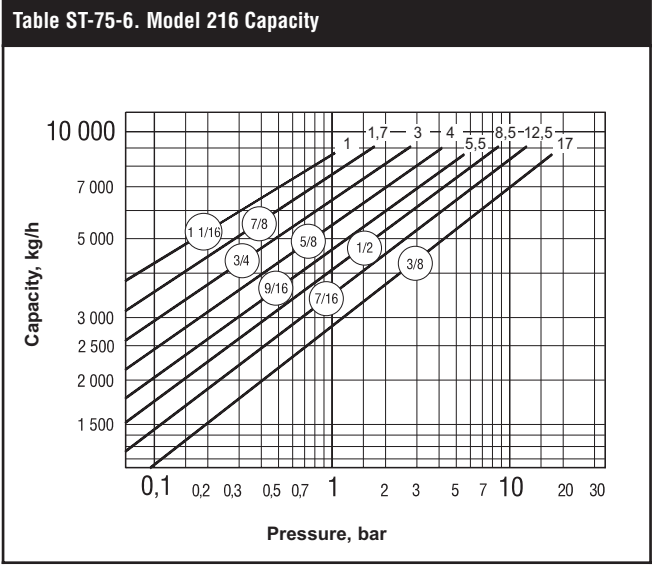
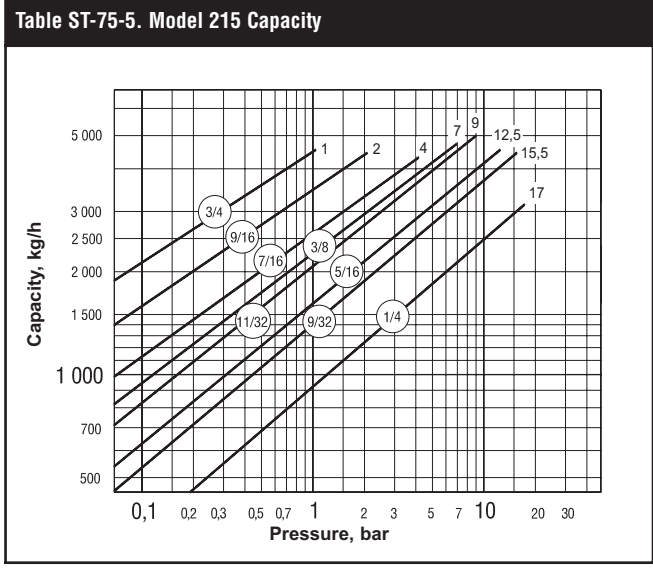
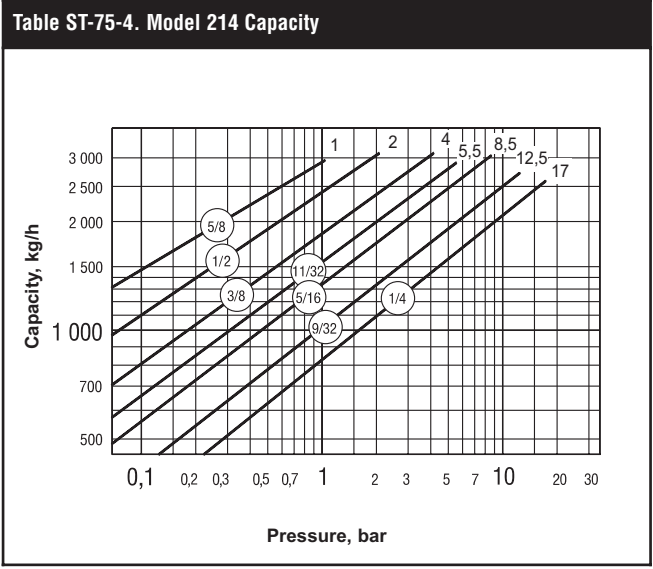
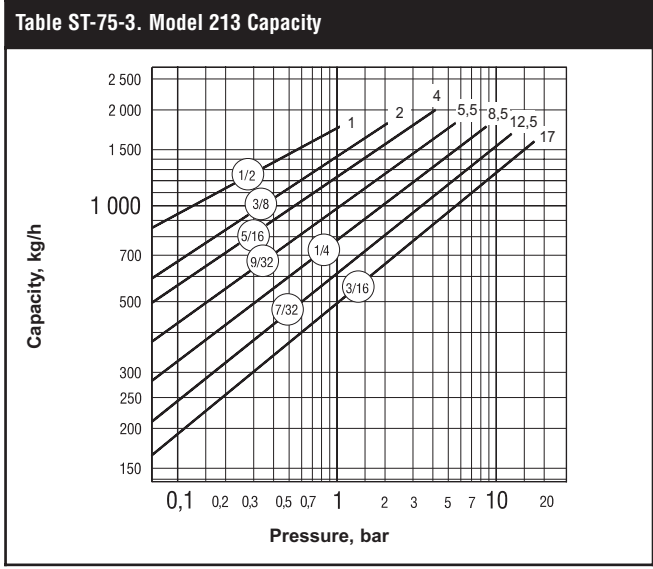
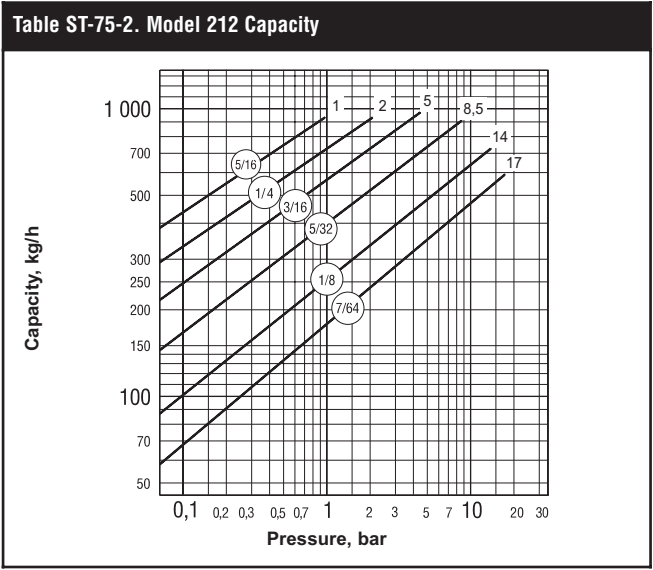
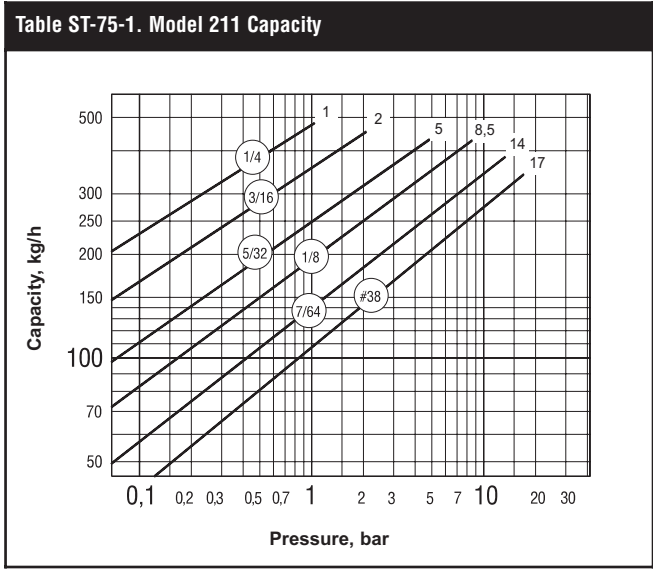

All dimensions and weights are approximate. Use certified print for exact dimensions. Design and materials are subject to change without notice.