

DIMENSIONS & DATA CERTIFIED FOR:

Representative:

Order:

Customer:

Order:

Project:

Requirements:

By:

Date:

LIST OF MATERIALS:

NAME OF PART	MATERIAL
CAP	ASTM A743 CA40
DISC	ASTM A276 GR 420
BODY	
NAME PLATE	T303 STN. STL.
RAIN GUARD (OPTIONAL)	
CONNECTOR:	
BLOCK, CONNECTOR	ASTM A351 GR. CF8 T304 SS
GASKET, CONNECTOR	T304 SS NON-ASBESTOS
RETAINING RING	CARBON STEEL
FLANGE	ASTM A105 CARBON STEEL, NICKEL PLATED
RETAINER, FLANGE	ASTM A276 T304 SS
BOLTS	ASTM A193, GR. B7, ZINC PLATED

TECHNICAL INFORMATION

MODEL NO.	CD-3300
CONNECTIONS	1/2[DN15]
	3/4[DN20]
"C" (FACE-TO-FACE)	2-3/8[60]
"D" (¢ TO BOTTOM OF FLG)	2-3/8[60]
"E" (OVERALL HEIGHT)	2-7/8[73]
"F" (¢ TO BODY END)	3-3/8[86]
"L" (OVERALL LENGTH)	4-3/16[106]
WEIGHT lbs[kgs] ±1/4[.11]	3.6[1.6]

OPTIONS:

CONNECTION	NPT	
	BSPT	
	SW	
RAIN GUARD		

DESIGN INFORMATION

MAX. OPERATING PRESSURE	450 psi at 456°F [31 bar at 236°C]
MAXIMUM ALLOWABLE PRESSURE (VESSEL DESIGN)	720 psi at 750°F [50 bar at 400°C]

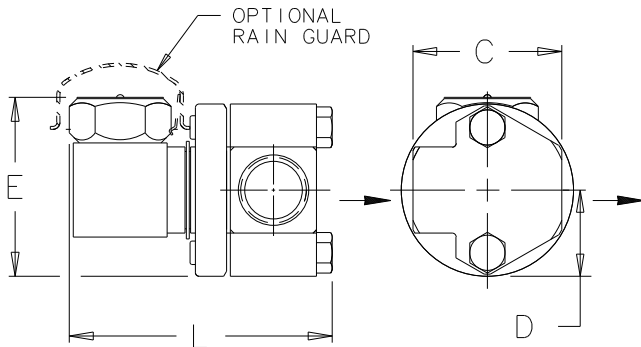
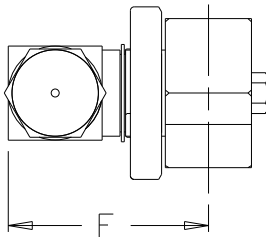

Dimensions Are In Inches[mm]



Product
TRAP
CD3300 W/
CONNECTOR

ENGLISH

CD No.

Date

WEB
Y|N
✓

1275

7/17/07

Rev; B

By; paulg